

Instituto Federal de Educação, Ciência e Tecnologia de Santa Catarina  
Departamento Acadêmico de Eletrônica  
Osciladores e Multivibradores

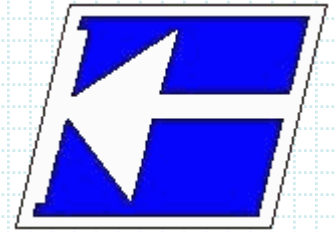

# Osciladores RC

## Deslocamento de Fase, Ponte de Wien, Duplo-T

Prof. Clóvis Antônio Petry.

Florianópolis, outubro de 2012.

# Bibliografia para esta aula



www·ProfessorPetry·com·br

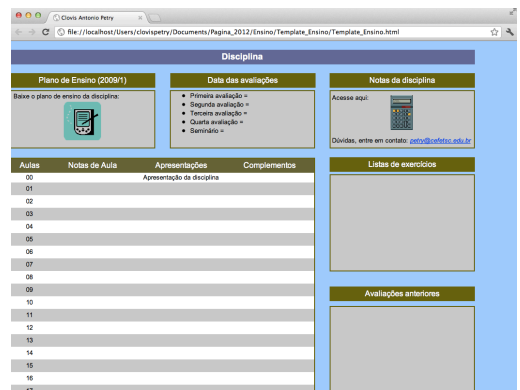
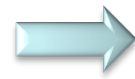

## Osciladores RC:

1. Considerações iniciais;
2. Oscilador de deslocamento de fase:
  - Com AmpOp;
  - Com BJT;
  - Simulação de osciladores de deslocamento de fase.
3. Oscilador com ponte de Wien:
  - Com AmpOp;
  - Com BJT;
  - Simulação de osciladores com ponte de Wien.
4. Oscilador duplo-t:
  - Com AmpOp;
  - Com BJT;
  - Simulação de osciladores duplo-t.

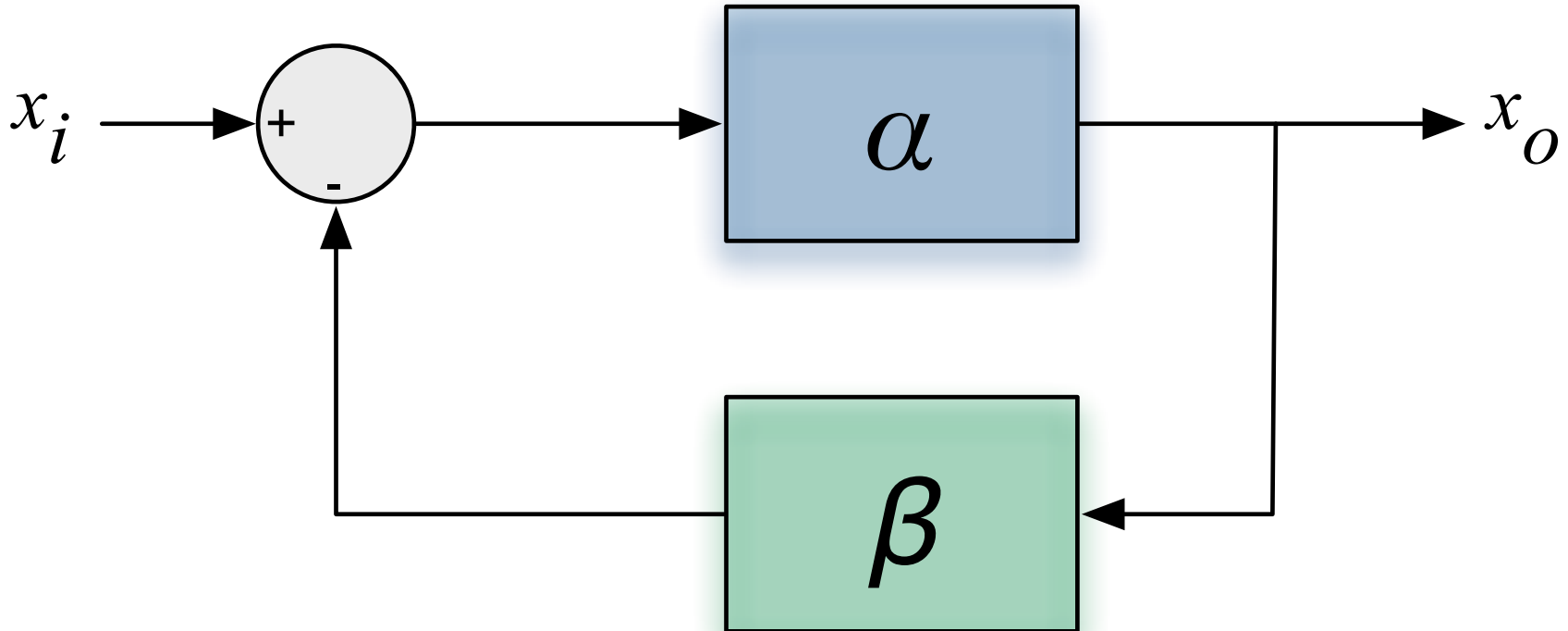

## Blocos do oscilador:

- Amplificador –  $\alpha$  – circuito de amplificação de sinais, ativo, formado por transistores e/ou amplificadores operacionais.
- Rede de realimentação –  $\beta$  – circuito de realimentação, normalmente com elementos passivos (resistores, capacitores e indutores).

# Oscilador de deslocamento de fase

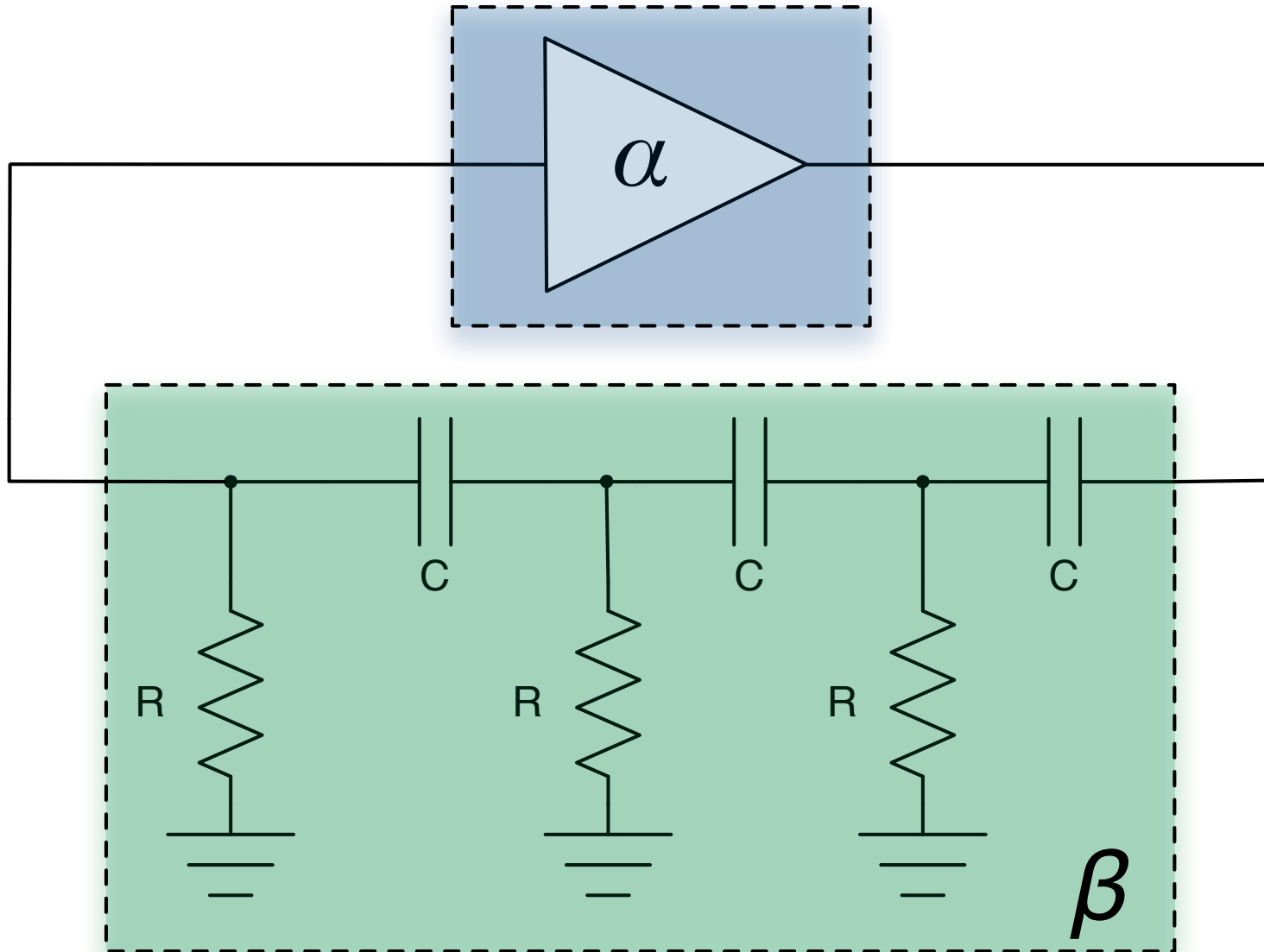

# Oscilador de deslocamento de fase com AmpOp

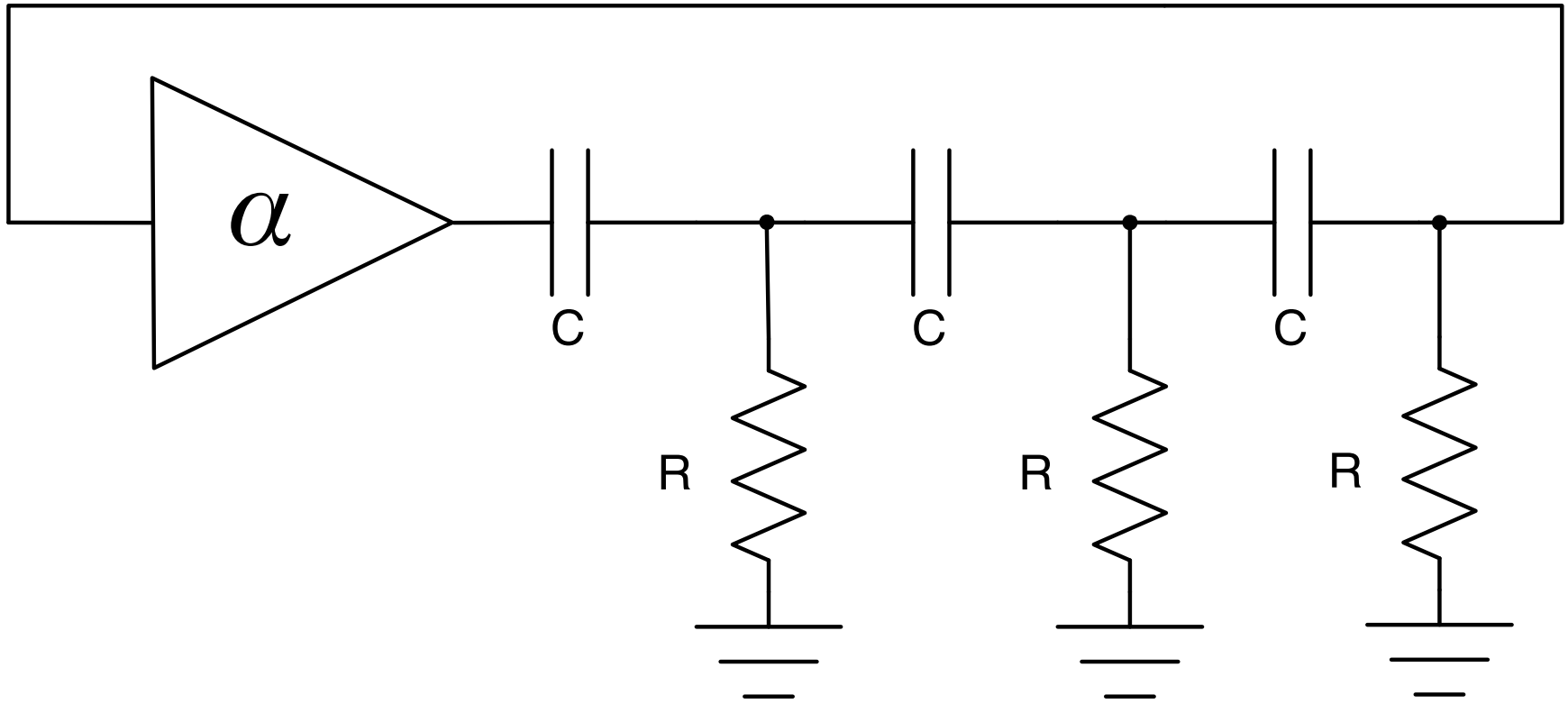

$$F_o = \frac{1}{2\pi \cdot \sqrt{6} \cdot R \cdot C}$$

$$\frac{v_o}{v_i} = -\frac{1}{29}$$

# Oscilador de deslocamento de fase com BJT

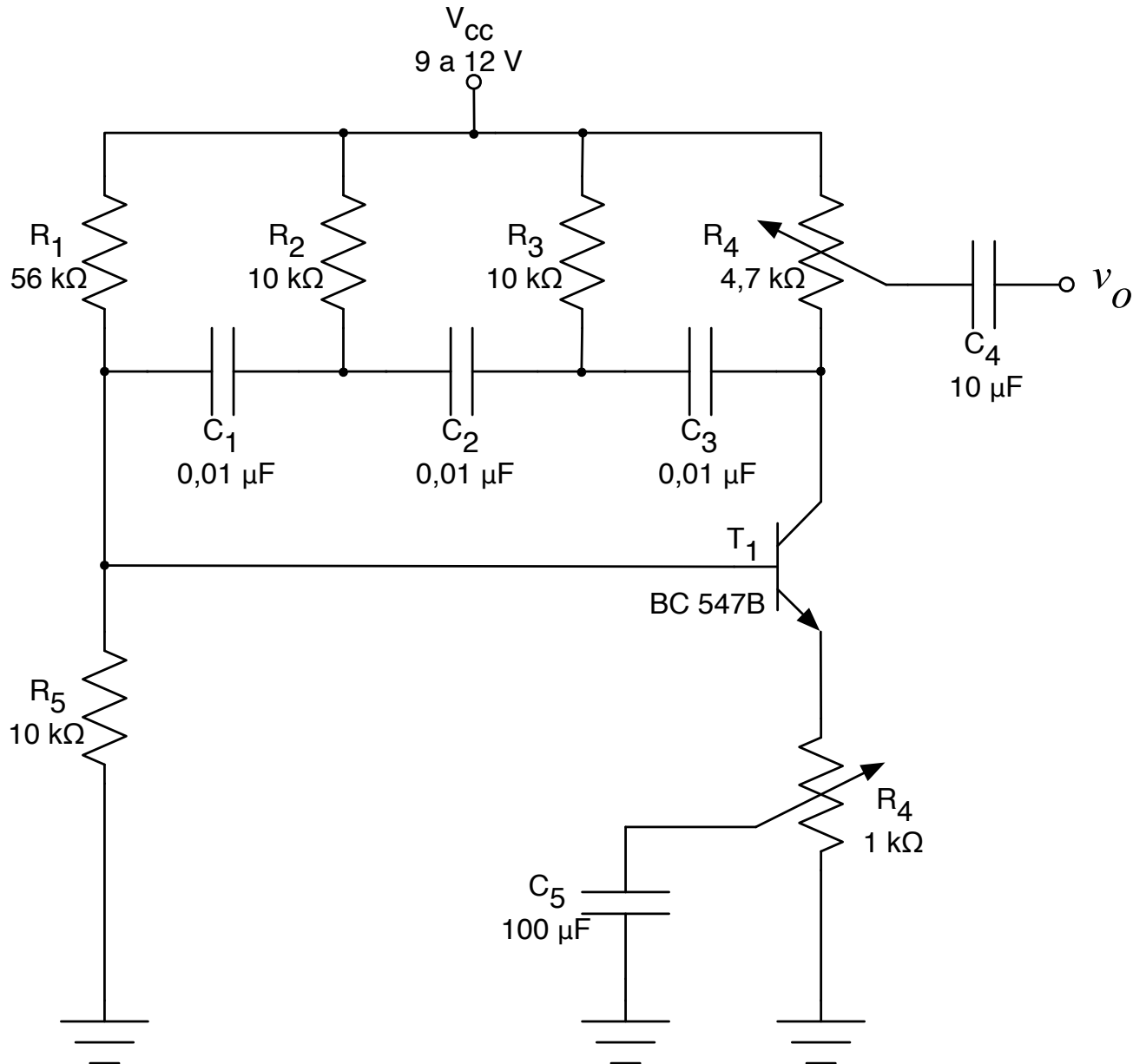

# Oscilador de deslocamento de fase com BJT

Circuito de polarização:

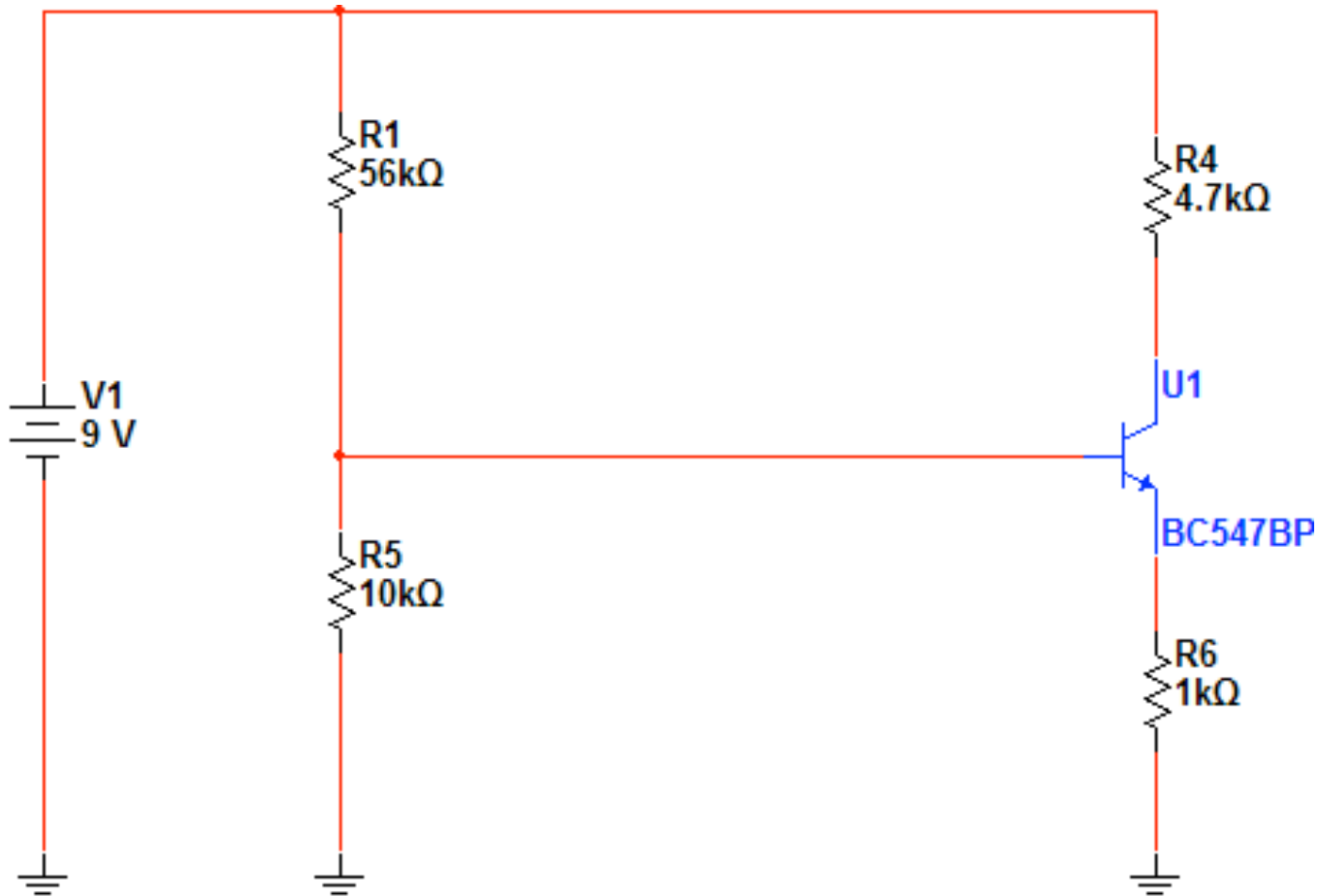



# Oscilador de deslocamento de fase com BJT

## Circuito de polarização:

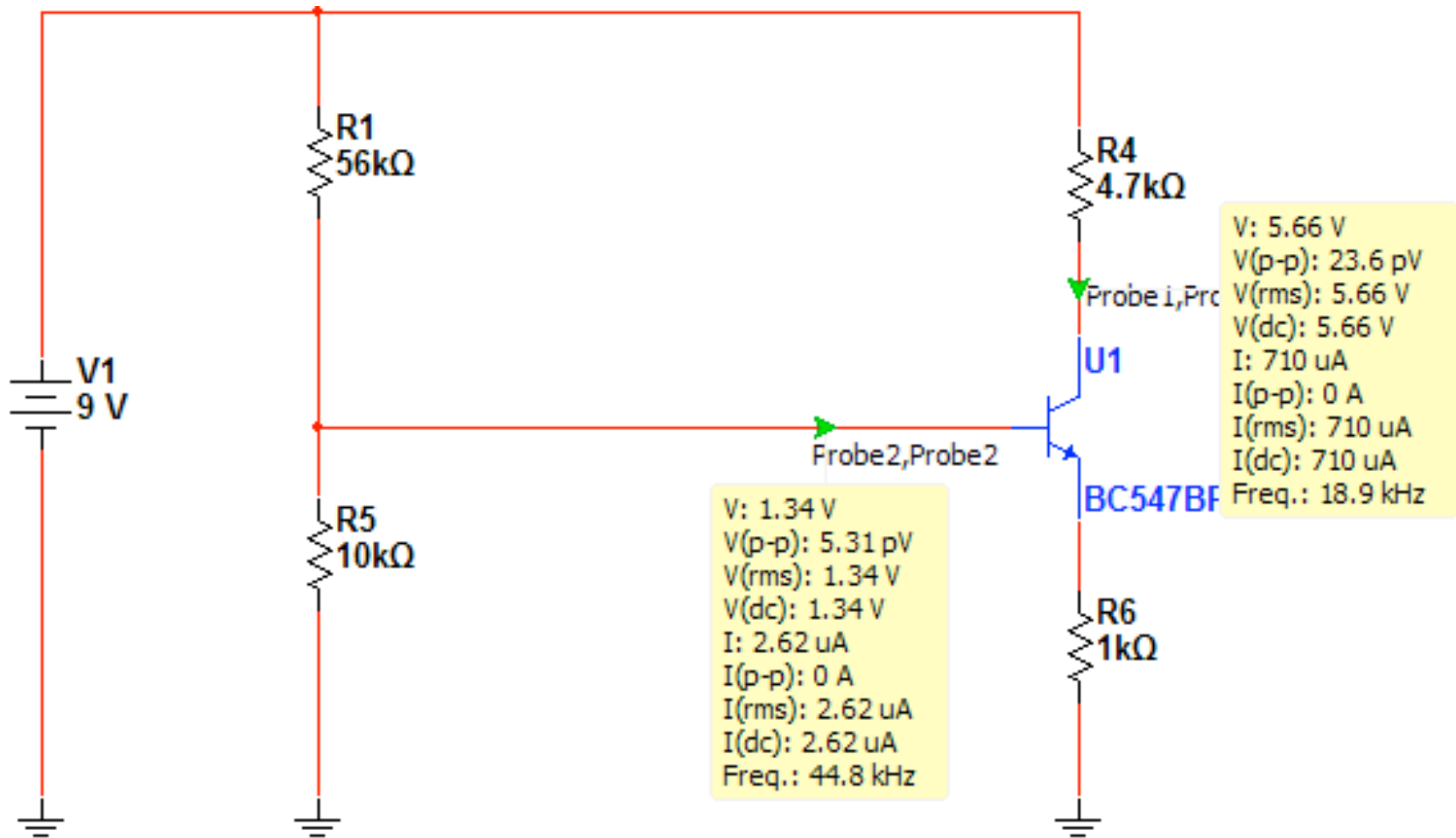

# Oscilador de deslocamento de fase com BJT

Circuito para simulação:

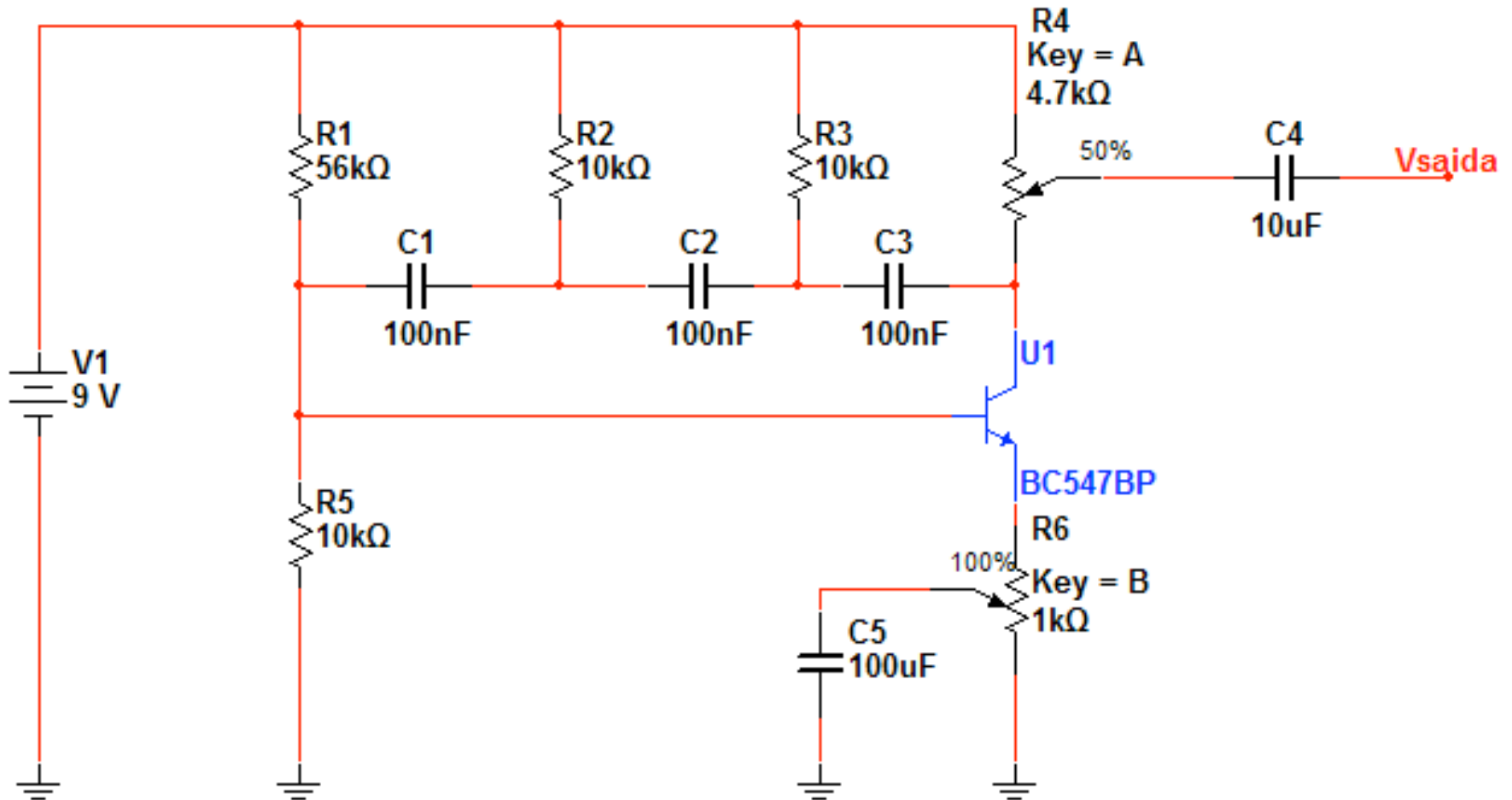

## Simulação do oscilador de deslocamento de fase:

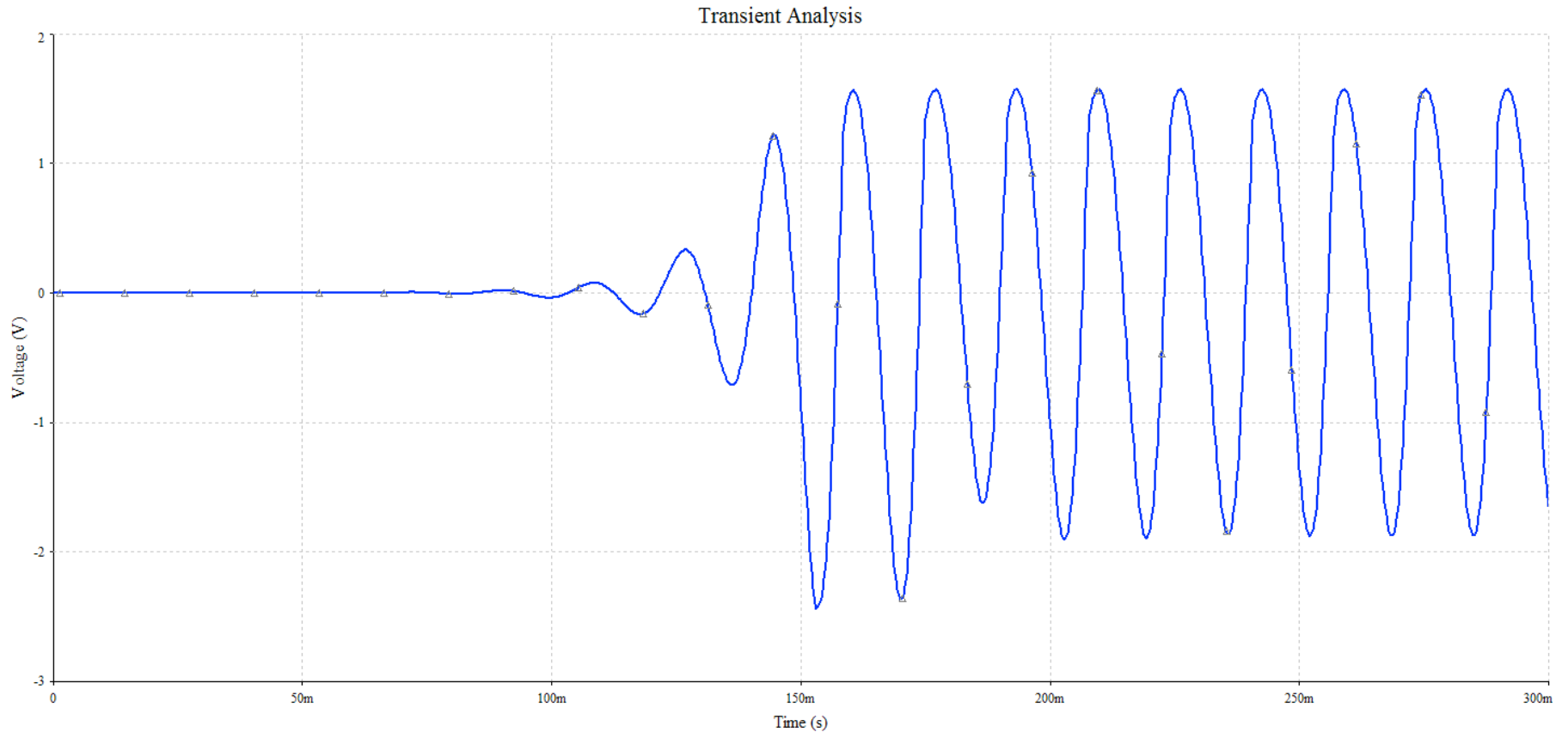

# Oscilador de deslocamento de fase com BJT

## Simulação do oscilador de deslocamento de fase:

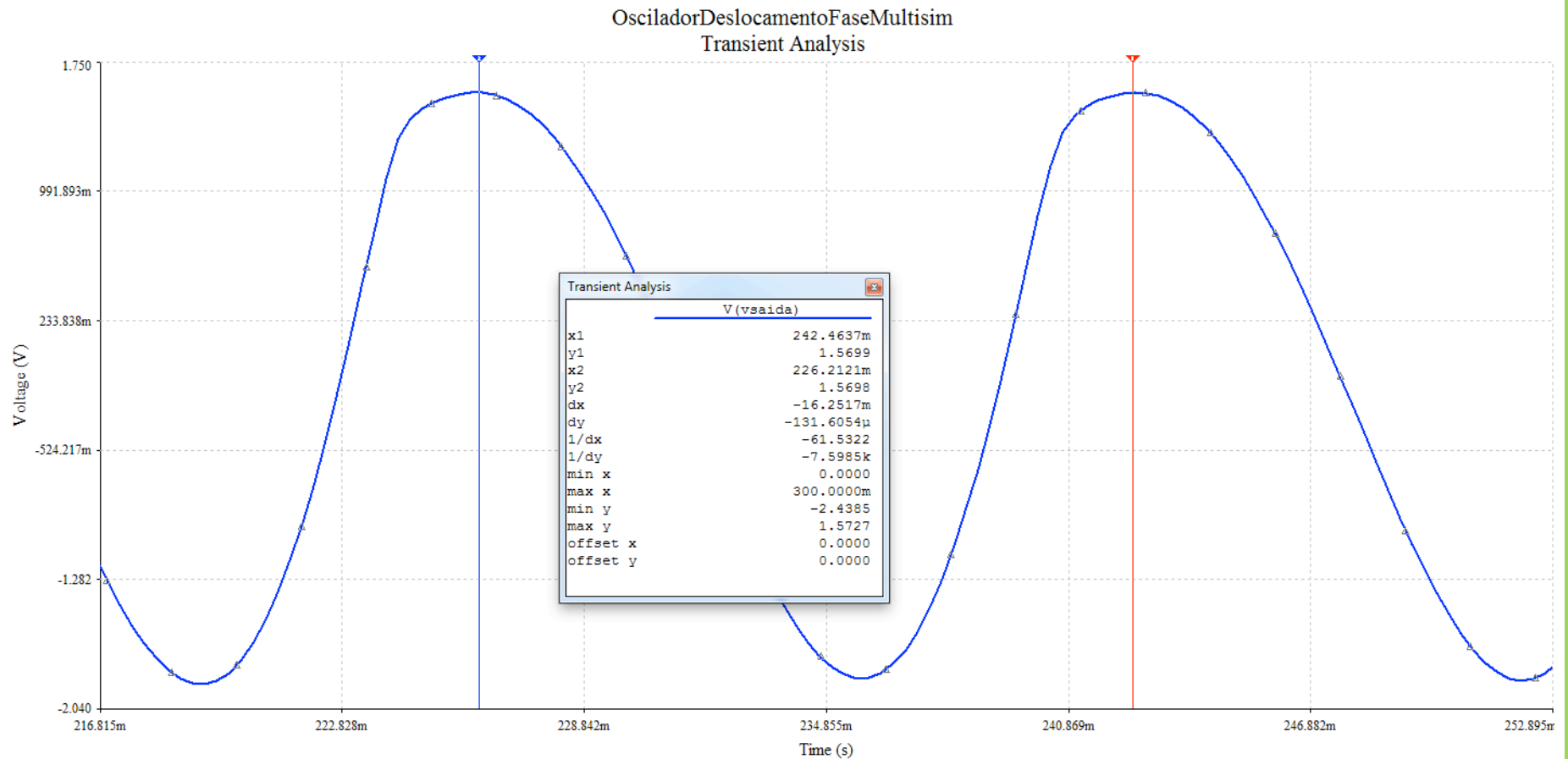

# Oscilador de deslocamento de fase com BJT

## Simulação do oscilador de deslocamento de fase:

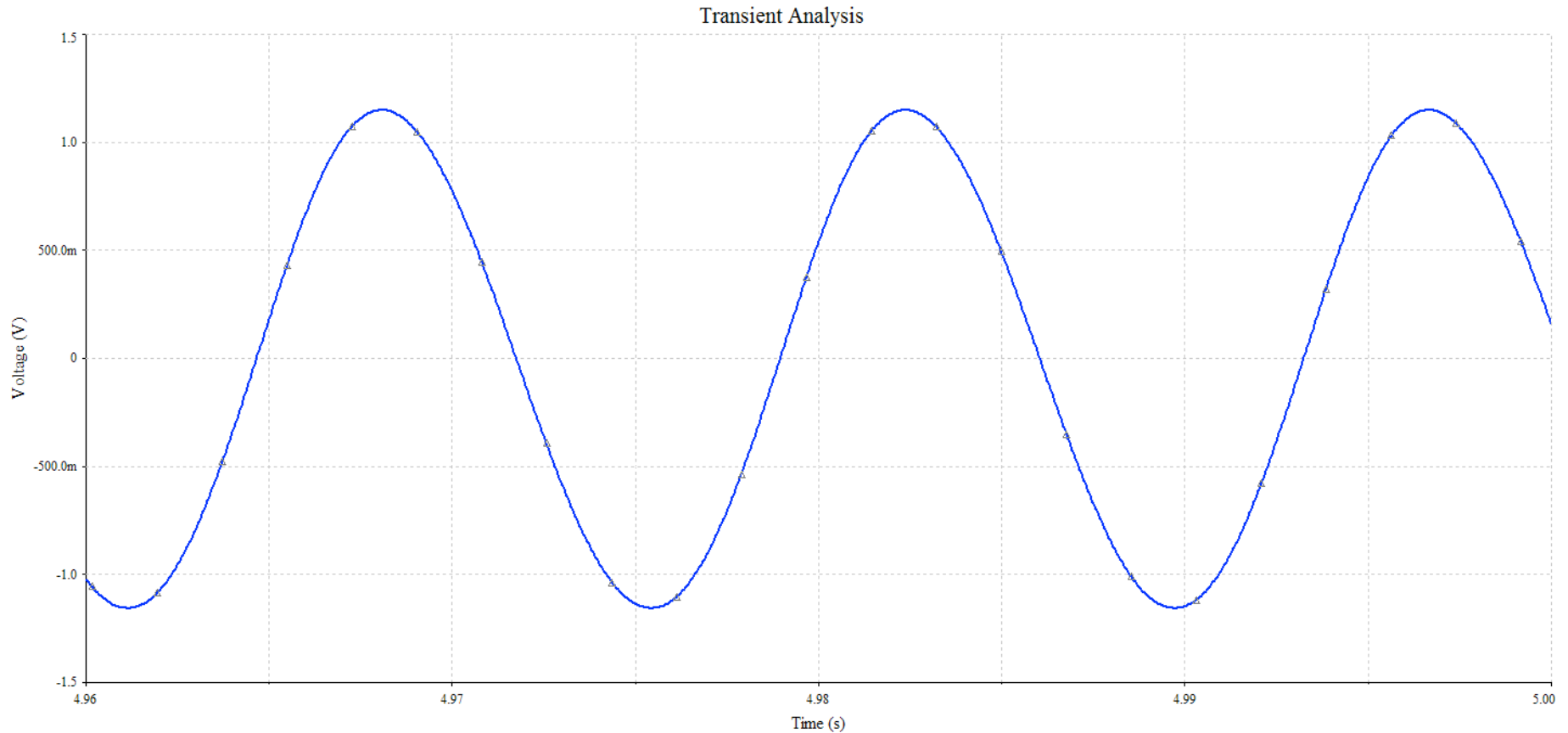

# Oscilador com ponte de Wien

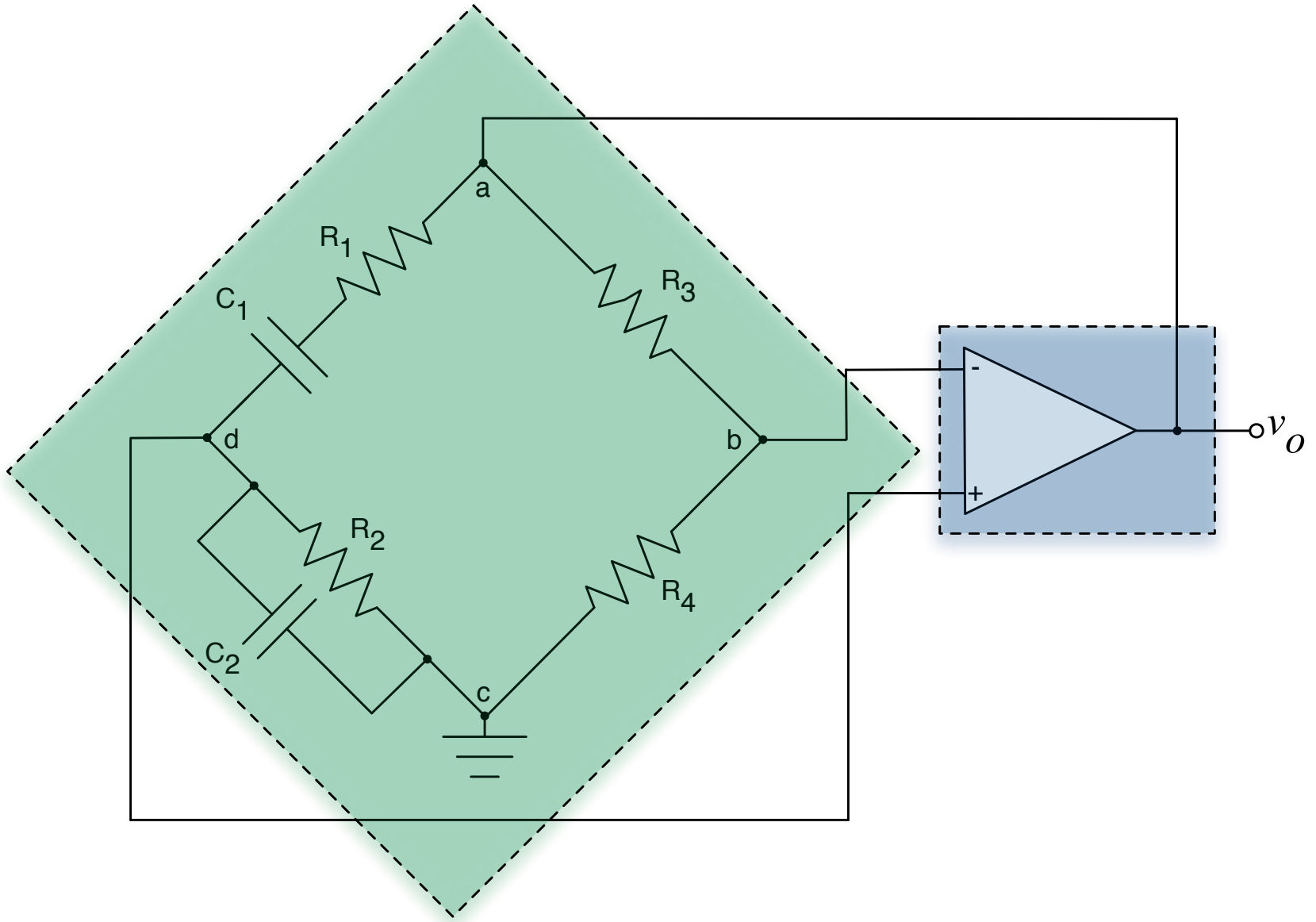



# Oscilador com ponte de Wien com AmpOp

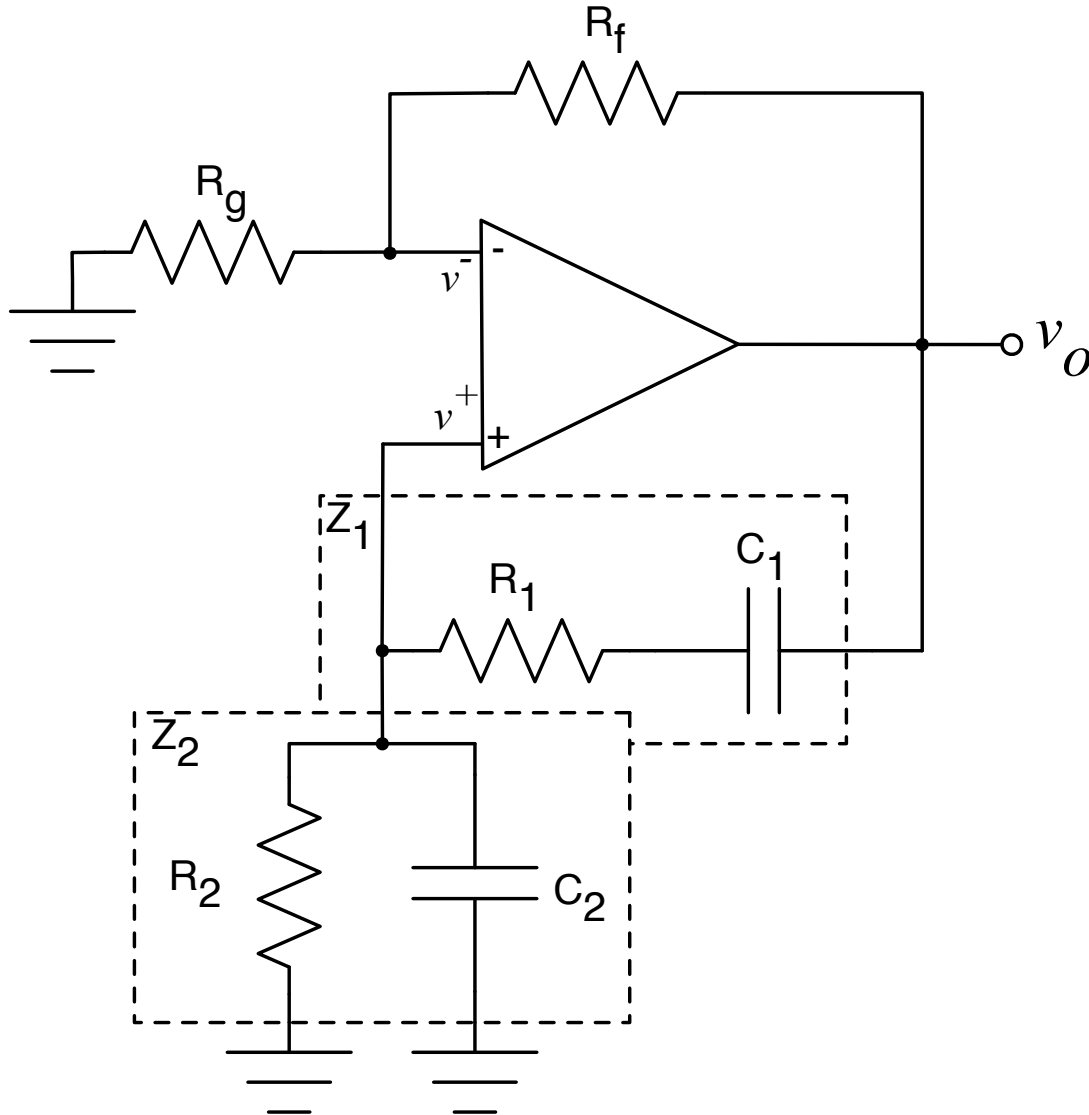

$$F_o = \frac{1}{2\pi \cdot R \cdot C}$$

$$\frac{v_+}{v_o} = \frac{1}{3}$$

$$\frac{v_-}{v_o} = \frac{R_g}{R_g + R_f}$$

$$\frac{R_f}{R_g} = 2$$

# Oscilador com ponte de Wien com BJT

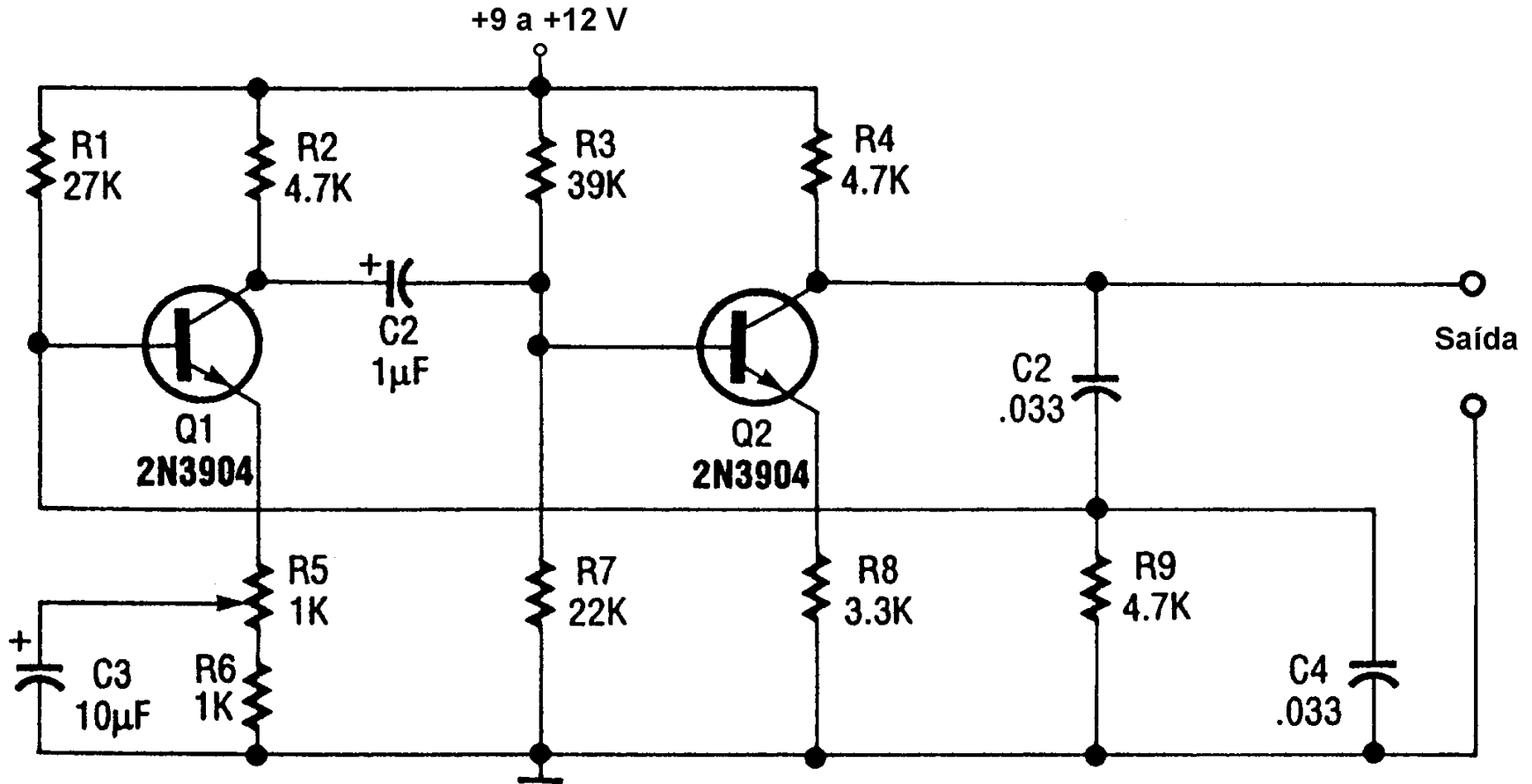

# Oscilador com ponte de Wien com BJT

Circuito de polarização:

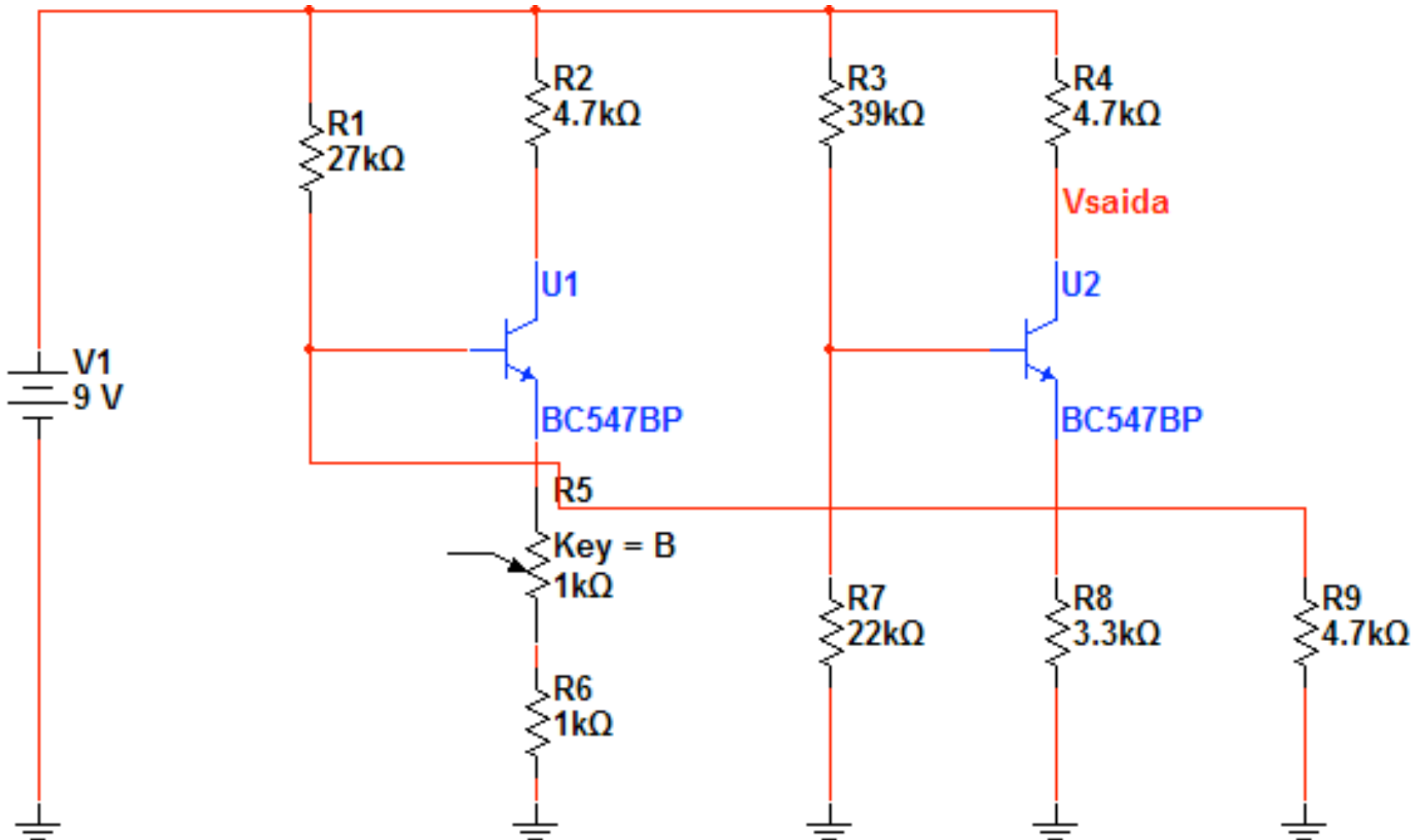



# Oscilador com ponte de Wien com BJT

Circuito de polarização:

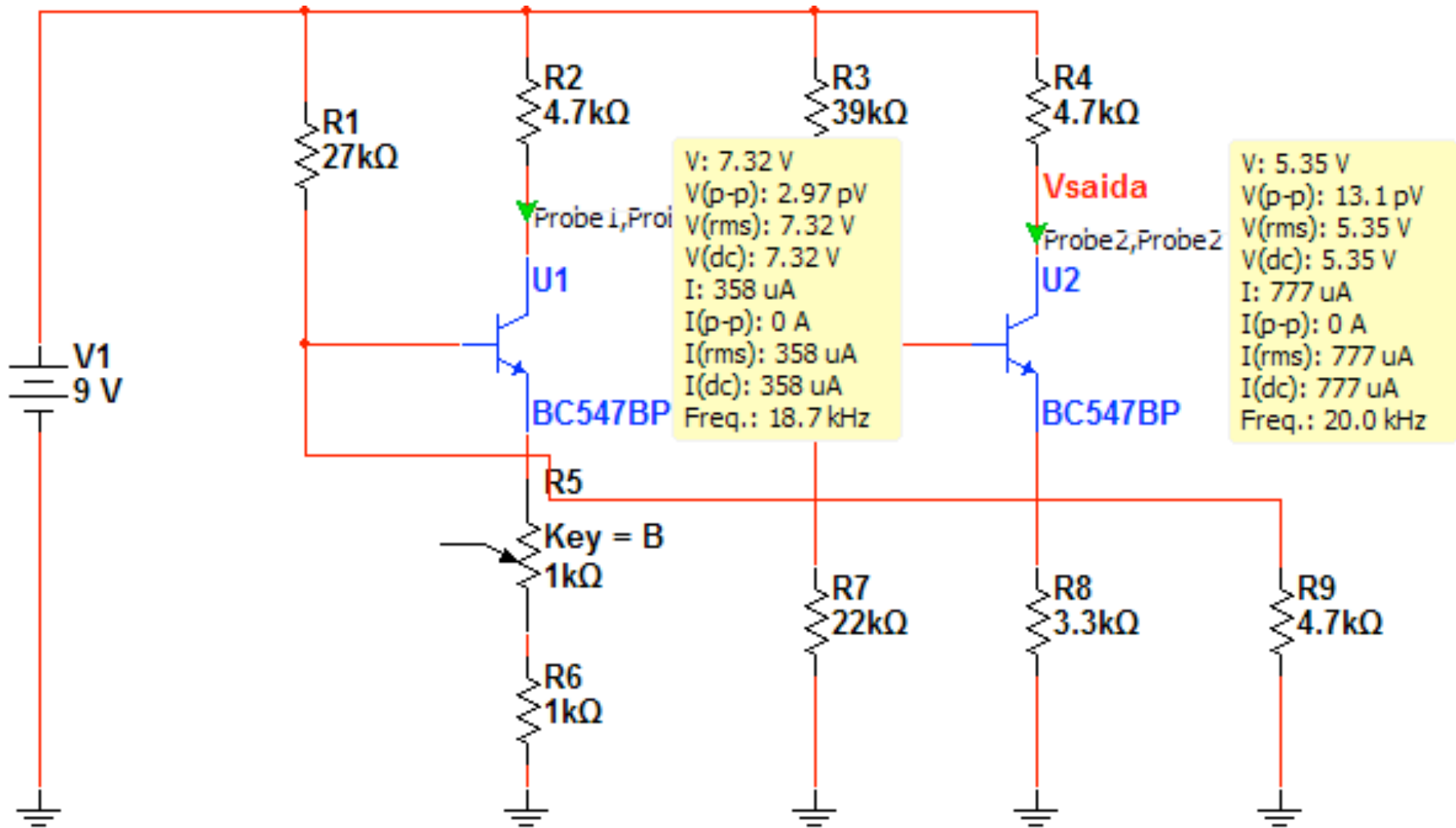



# Oscilador com ponte de Wien com BJT

Circuito para simulação:

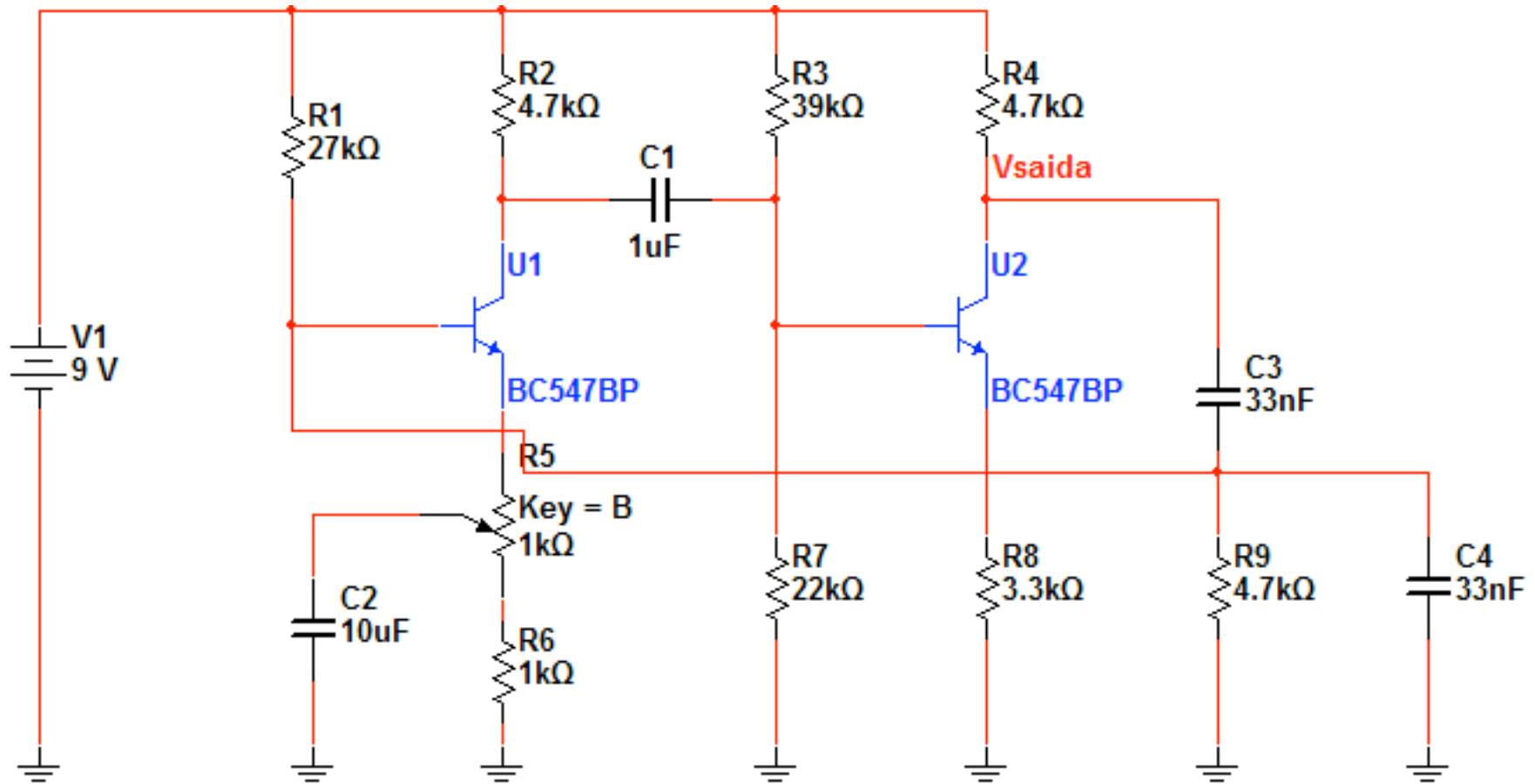

# Oscilador com ponte de Wien com BJT

## Simulação do oscilador com ponte de Wien:

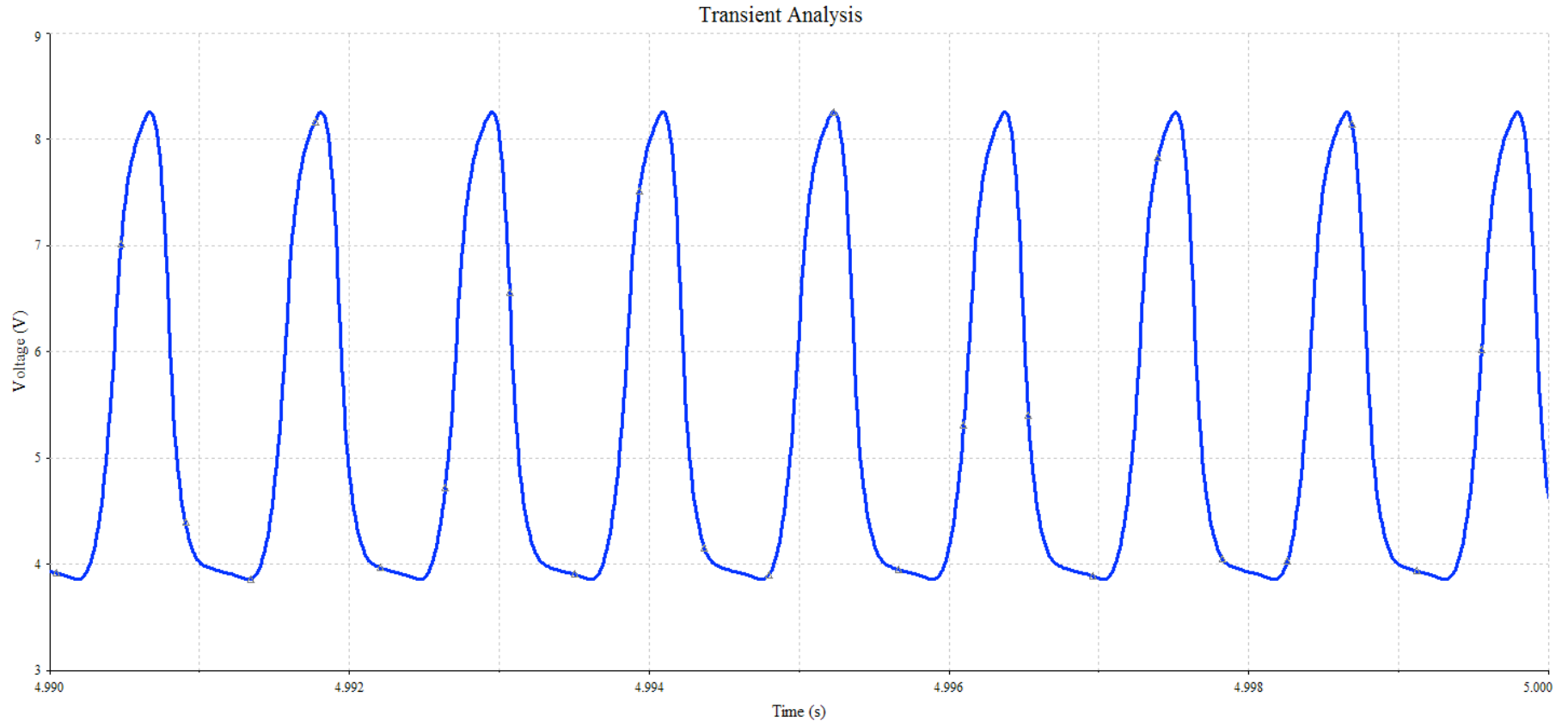

**Precisa de ajustes em  $R_5$ .**

# Oscilador com ponte de Wien com BJT

## Simulação do oscilador com ponte de Wien:

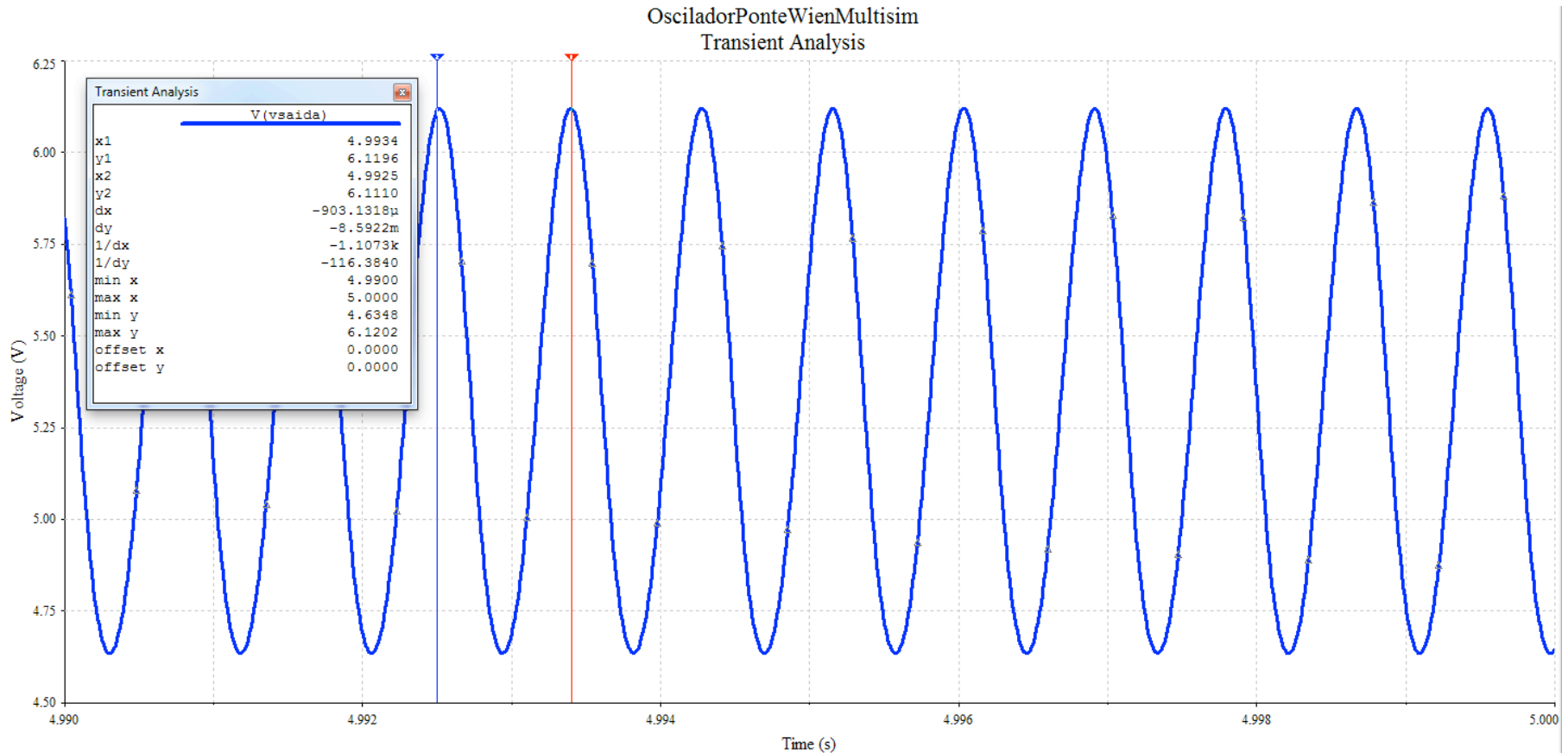

$$F_o \approx 1.107,42 k\Omega$$

## Rede de realimentação em duplo-t:

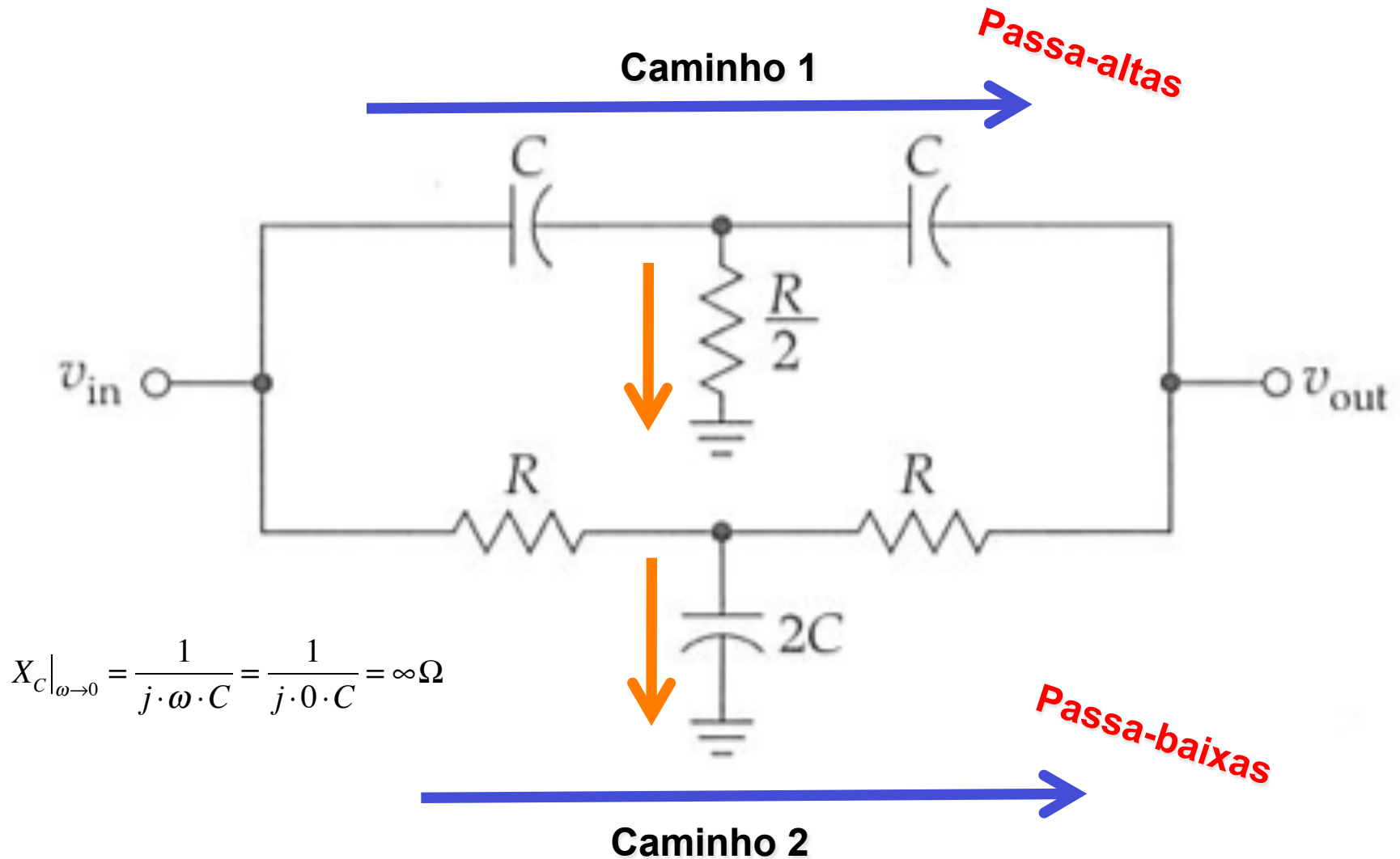

## Rede de realimentação em duplo-t:

$$X_C|_{\omega \rightarrow 0} = \frac{1}{j \cdot \omega \cdot C} = \frac{1}{j \cdot 0 \cdot C} = \infty \Omega \quad X_C|_{\omega \rightarrow \infty} = \frac{1}{j \cdot \omega \cdot C} = \frac{1}{j \cdot \infty \cdot C} = 0 \Omega$$

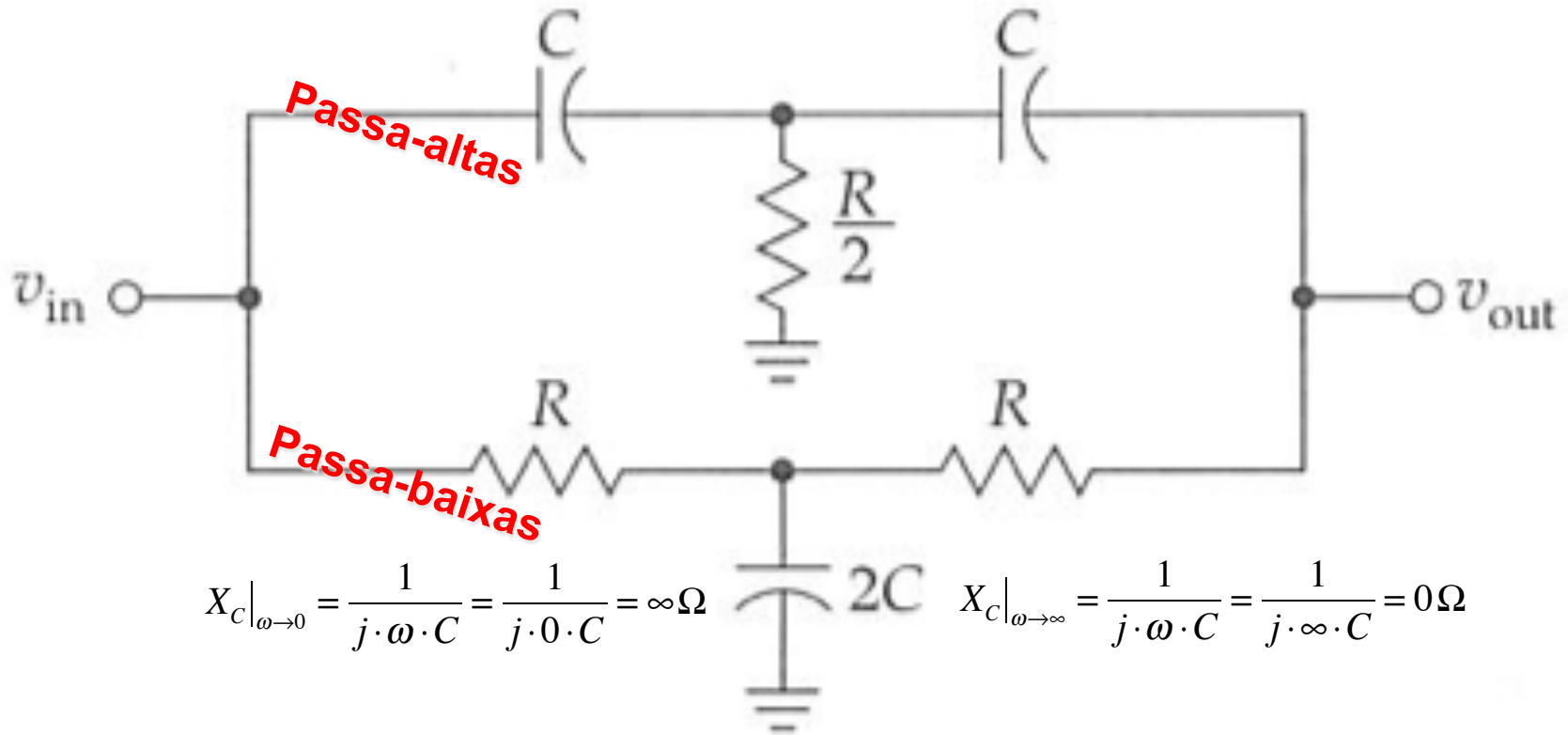

# Oscilador em duplo-t

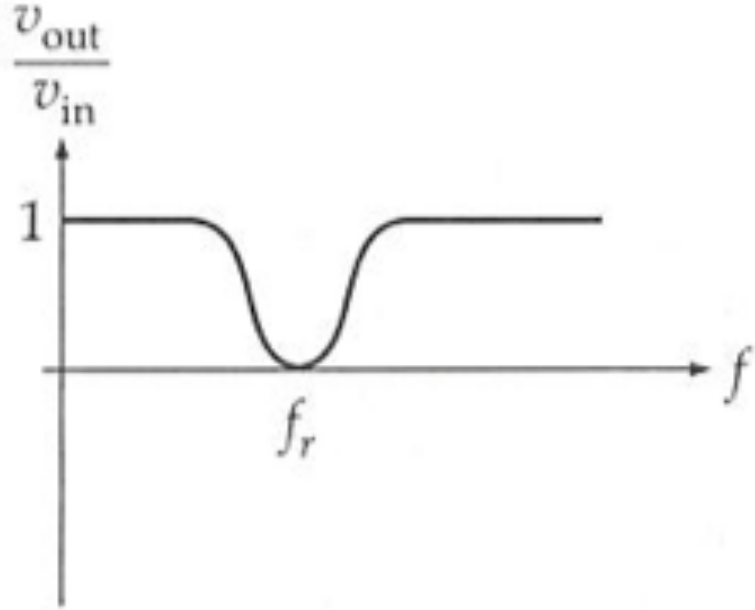

**Ganho de tensão do filtro duplo-t**

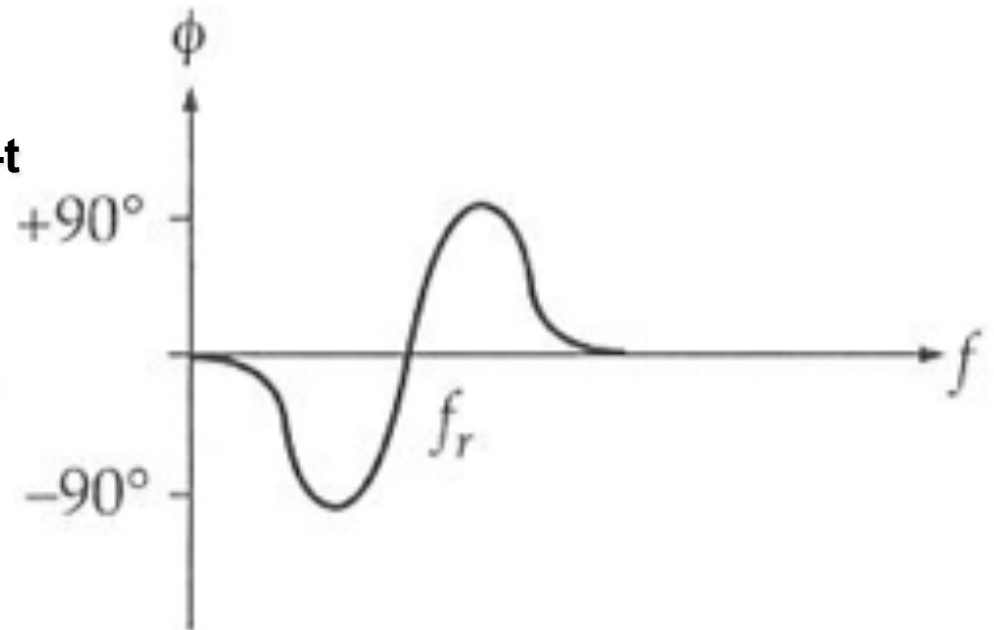

**Deslocamento de fase do filtro duplo-t**

# Oscilador em duplo-t com AmpOp

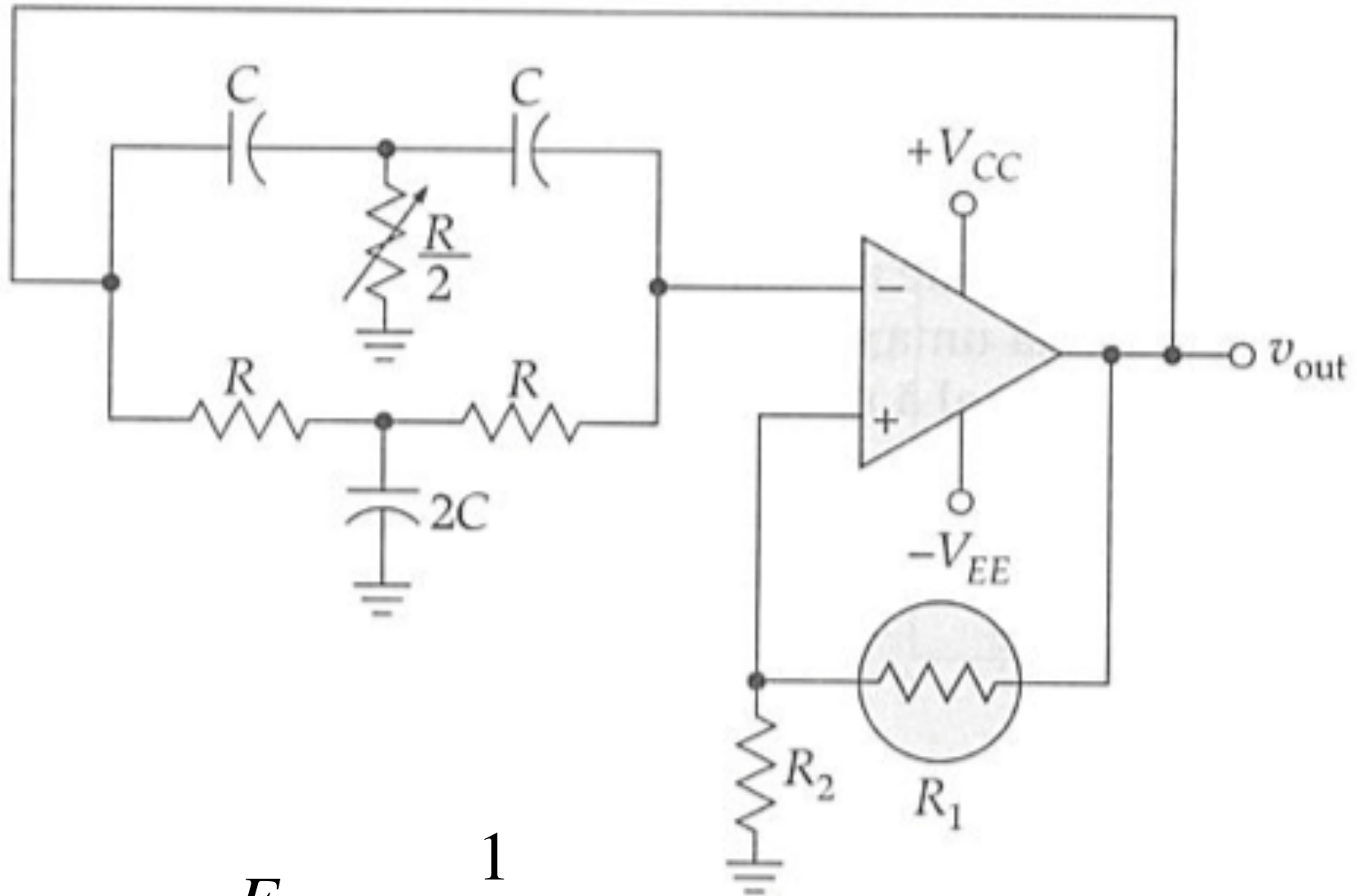

$$F_o = \frac{1}{2\pi \cdot R \cdot C}$$

# Oscilador em duplo-t com BJT

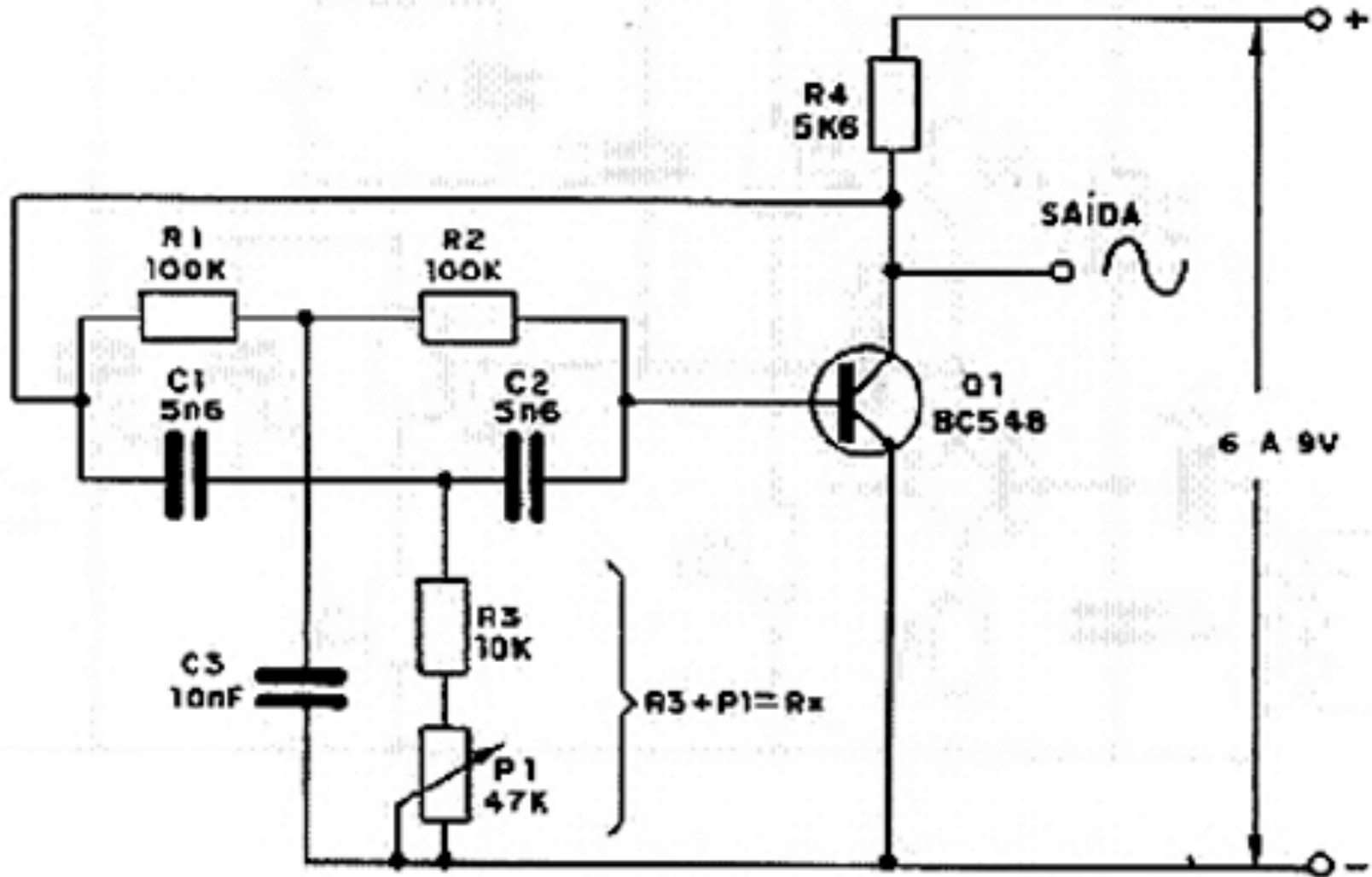

# Oscilador em duplo-t com BJT

Circuito de polarização:

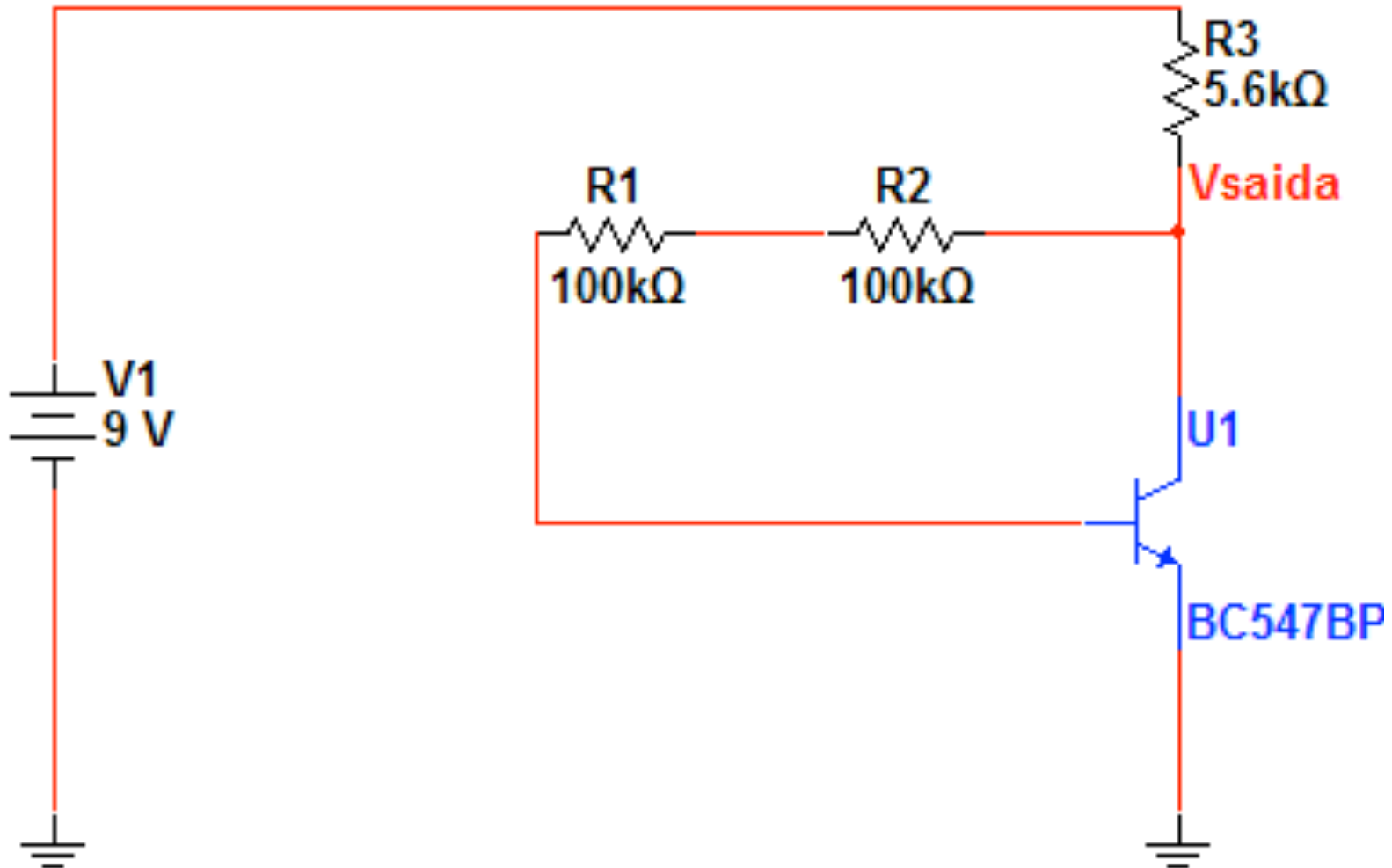



# Oscilador em duplo-t com BJT

## Circuito de polarização:

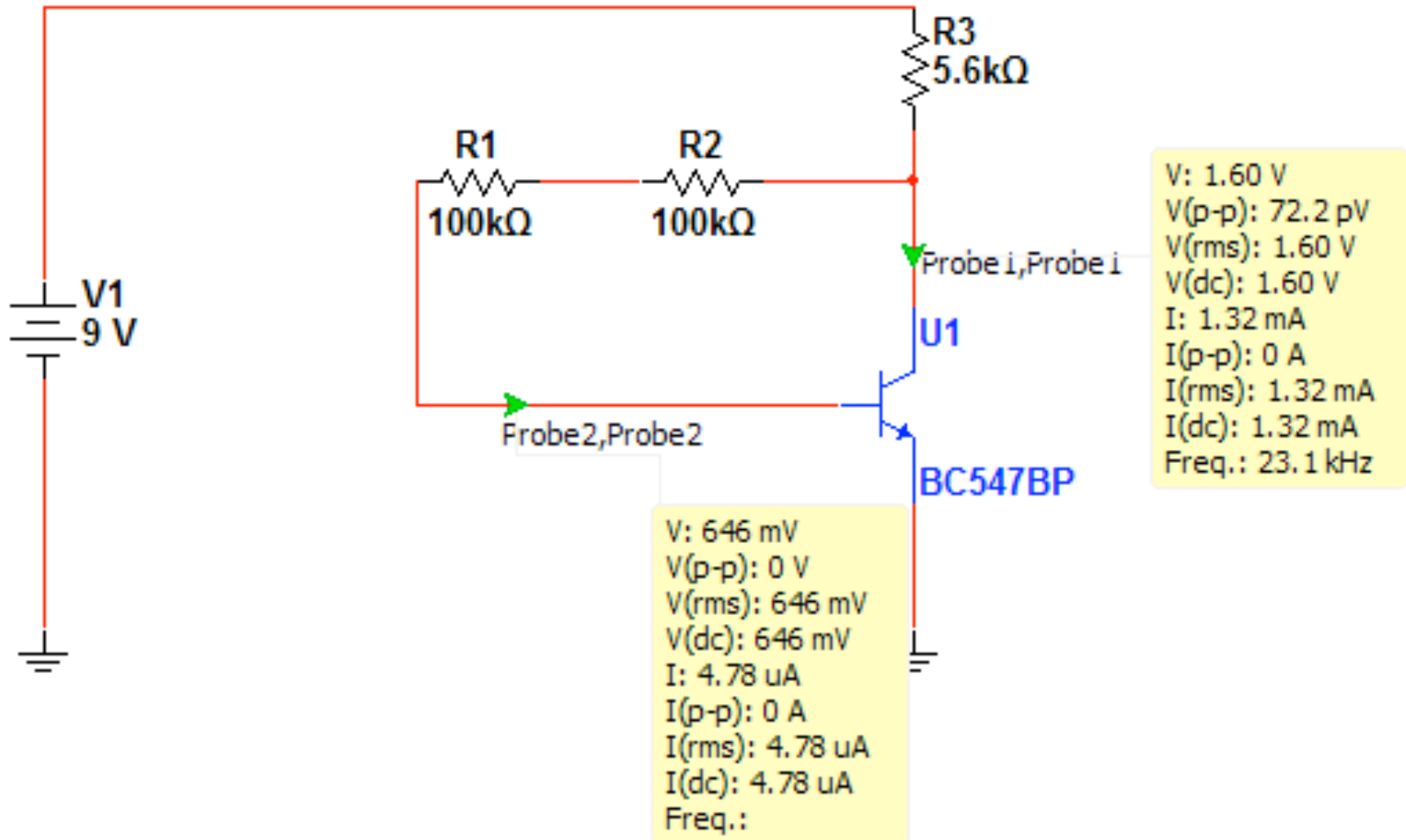

# Oscilador em duplo-T com BJT

Circuito para simulação:

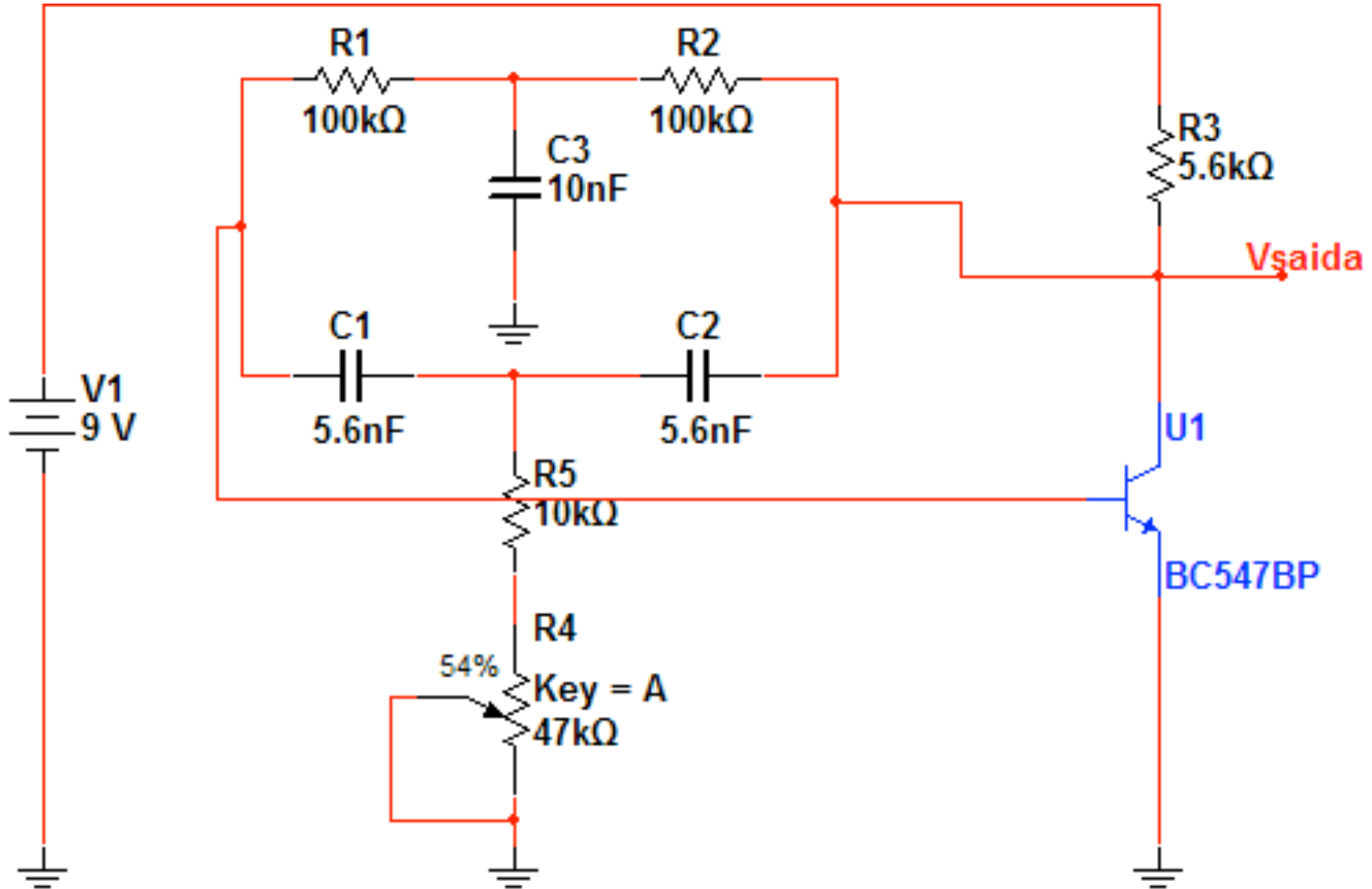

$$F_o = \frac{1}{2\pi \cdot R \cdot C} = \frac{1}{2\pi \cdot 100 \cdot 10^3 \cdot 5,6 \cdot 10^{-9}} = 284,35 \text{ Hz}$$

## Simulação do oscilador em duplo-t:

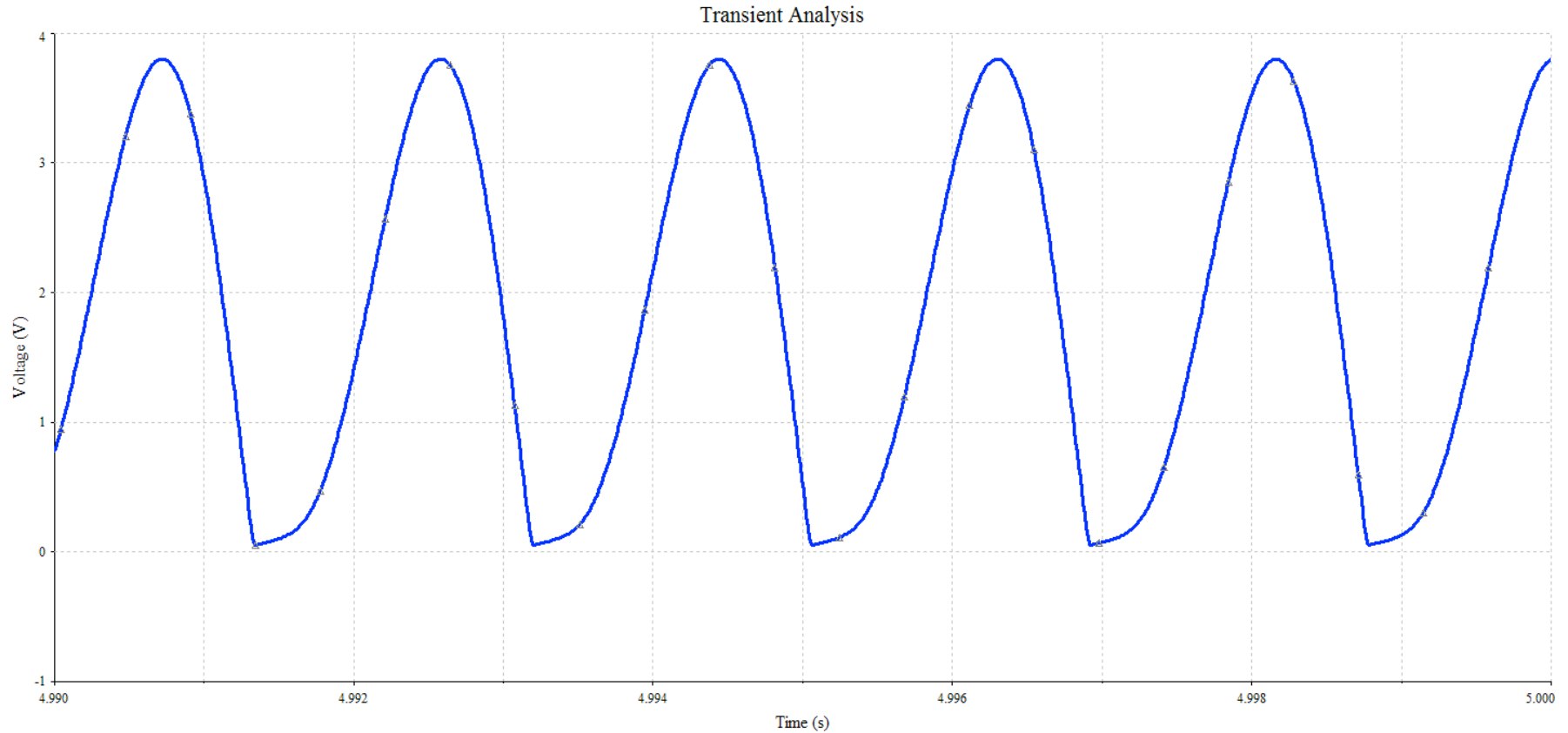

**Precisa de ajustes em  $R_4$ .**

## Simulação do oscilador em duplo t:

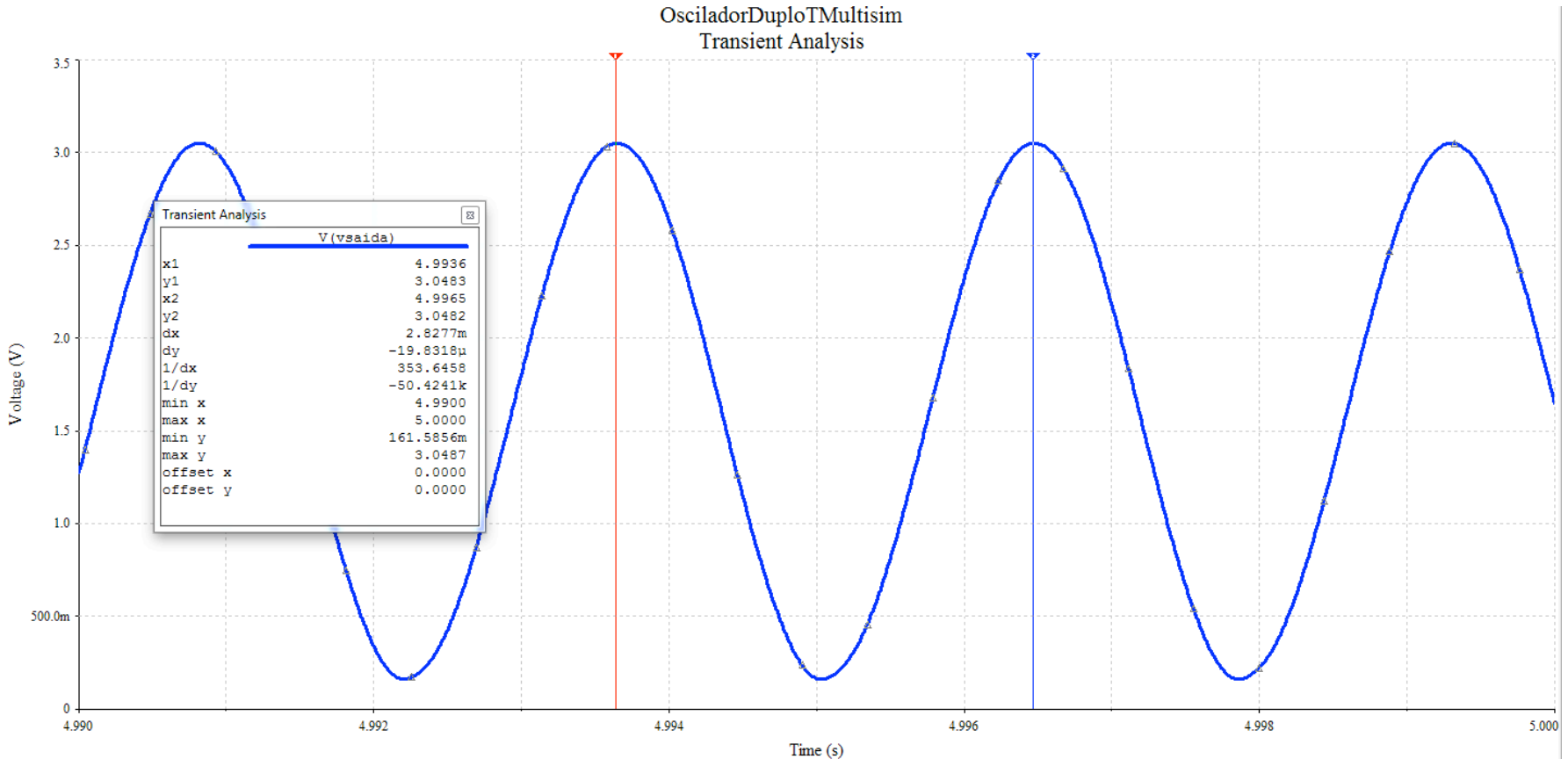

$$F_o \approx 353,64 \text{ Hz}$$

## Exercícios de Osciladores RC.

