

Instituto Federal de Educação, Ciência e Tecnologia de Santa Catarina  
Departamento Acadêmico de Eletrônica  
Osciladores e Multivibradores

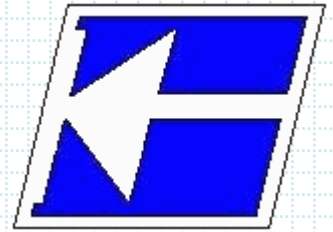

# Osciladores Sintonizados: Colpits, Clapp, Hartley e Armstrong

Prof. Clóvis Antônio Petry.

Florianópolis, outubro de 2012.

# Bibliografia para esta aula



www·ProfessorPetry·com·br

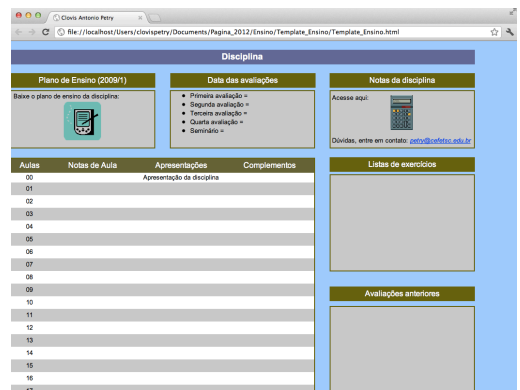
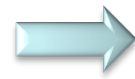

## Osciladores sintonizados:

1. Considerações iniciais;
2. Oscilador Colppits:
  - Com AmpOp;
  - Com BJT;
  - Simulação de osciladores Colppits.
3. Oscilador Clapp:
  - Com AmpOp;
  - Com BJT;
  - Simulação de osciladores Clapp.
4. Oscilador Hartley:
  - Com AmpOp;
  - Com BJT;
  - Simulação de osciladores Hartley.
5. Oscilador Armstrong:
  - Com AmpOp;
  - Com BJT;
  - Simulação de osciladores Armstrong.

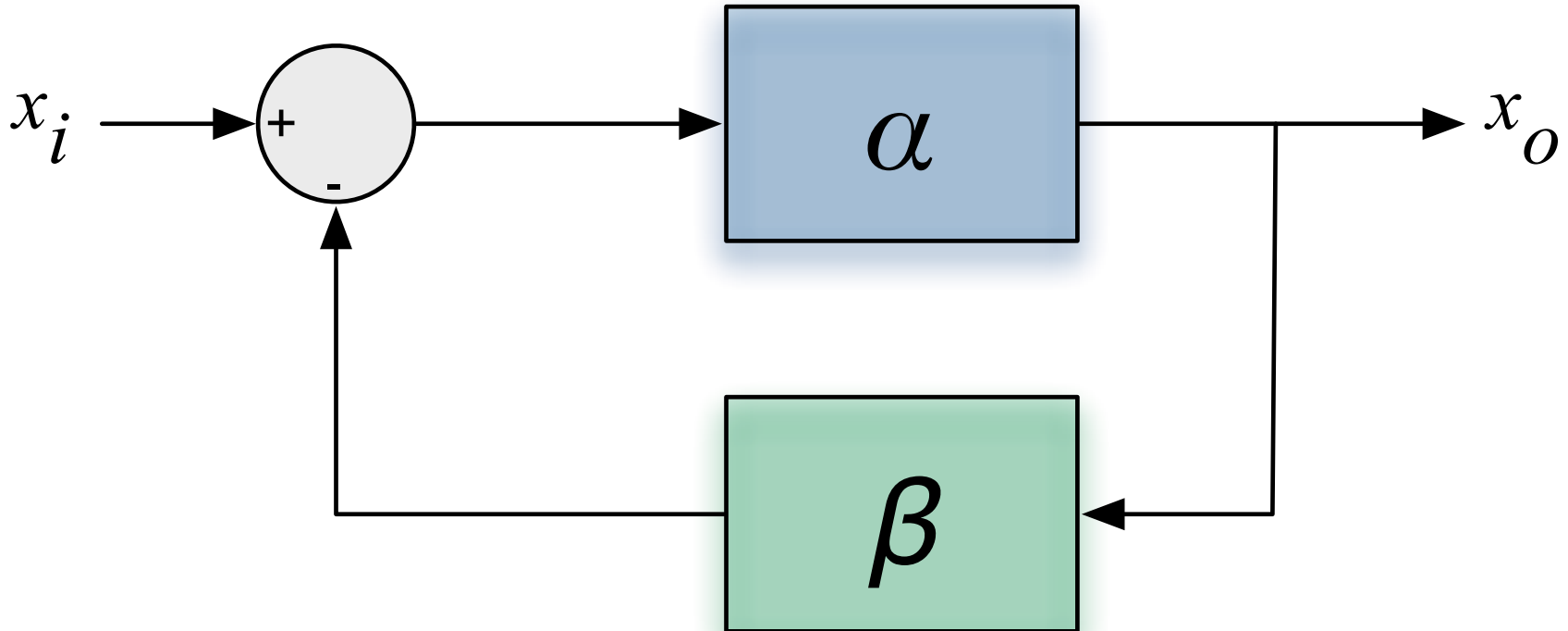

## Blocos do oscilador:

- Amplificador –  $\alpha$  – circuito de amplificação de sinais, ativo, formado por transistores e/ou amplificadores operacionais.
- Rede de realimentação –  $\beta$  – circuito de realimentação, normalmente com elementos passivos (resistores, capacitores e indutores).

## Rede de realimentação de um oscilador sintonizado:

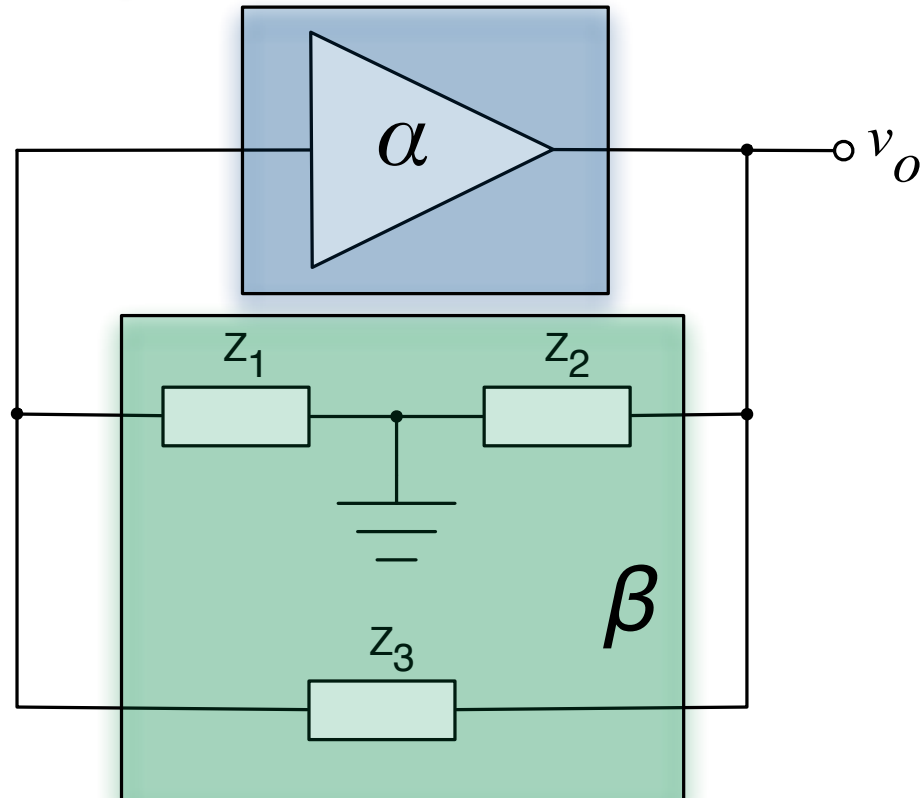

Tipo de oscilador	Elemento reativo		
	$X_1$	$X_2$	$X_3$
Oscilador Colppits	C	C	L
Oscilador Hartley	L	L	C
Sintonizado na entrada e na saída	LC	LC	-



# Oscilador Colpits com AmpOp

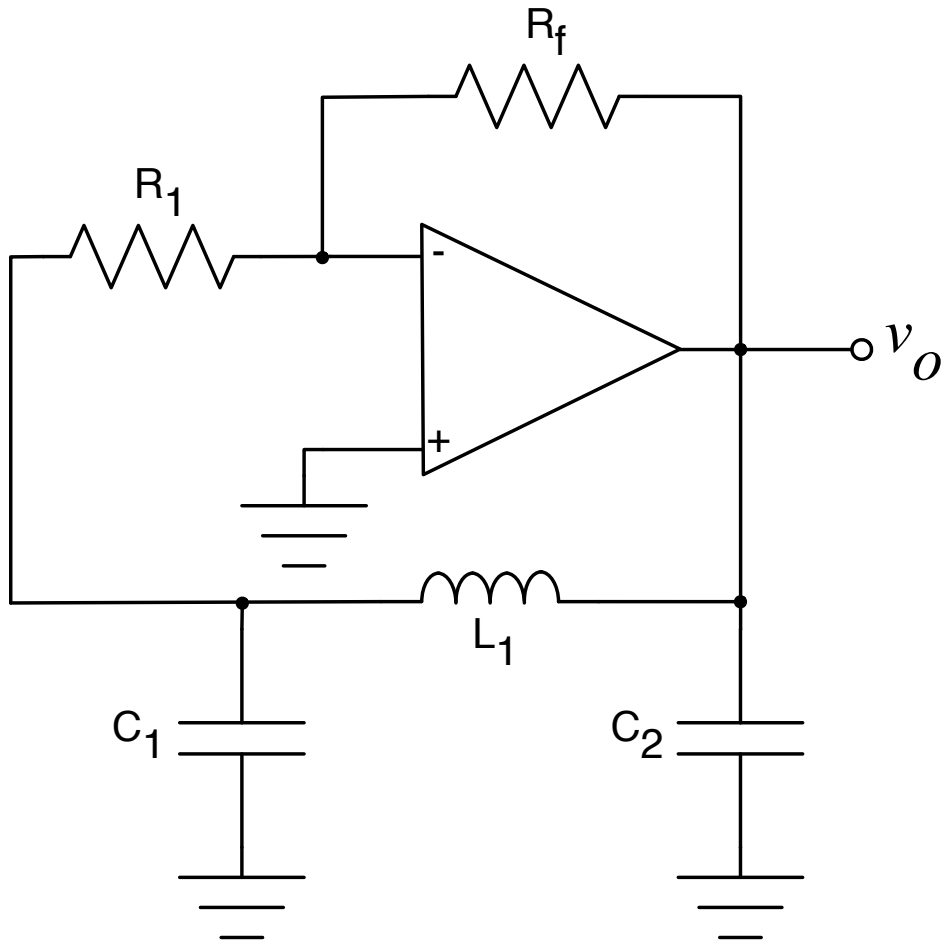

$$F_o = \frac{1}{2\pi \cdot \sqrt{L \cdot C_T}}$$

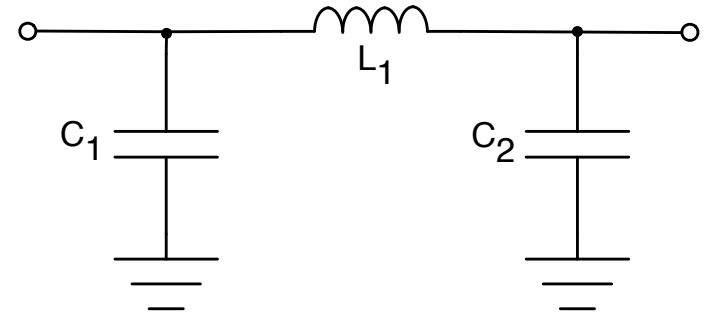

$$Z = \frac{C_2 \cdot L_1 \cdot \omega^2 - 1}{j \cdot (C_1 \cdot C_2 \cdot L_1 \cdot \omega^2 - C_1 - C_2)}$$

$$C_1 \cdot C_2 \cdot L_1 \cdot \omega^2 = C_1 + C_2$$

$$\omega = \frac{1}{\sqrt{L_1 \cdot \frac{C_1 \cdot C_2}{C_1 + C_2}}}$$

$$C_T = \frac{C_1 \cdot C_2}{C_1 + C_2}$$

# Oscilador Colppits com AmpOp

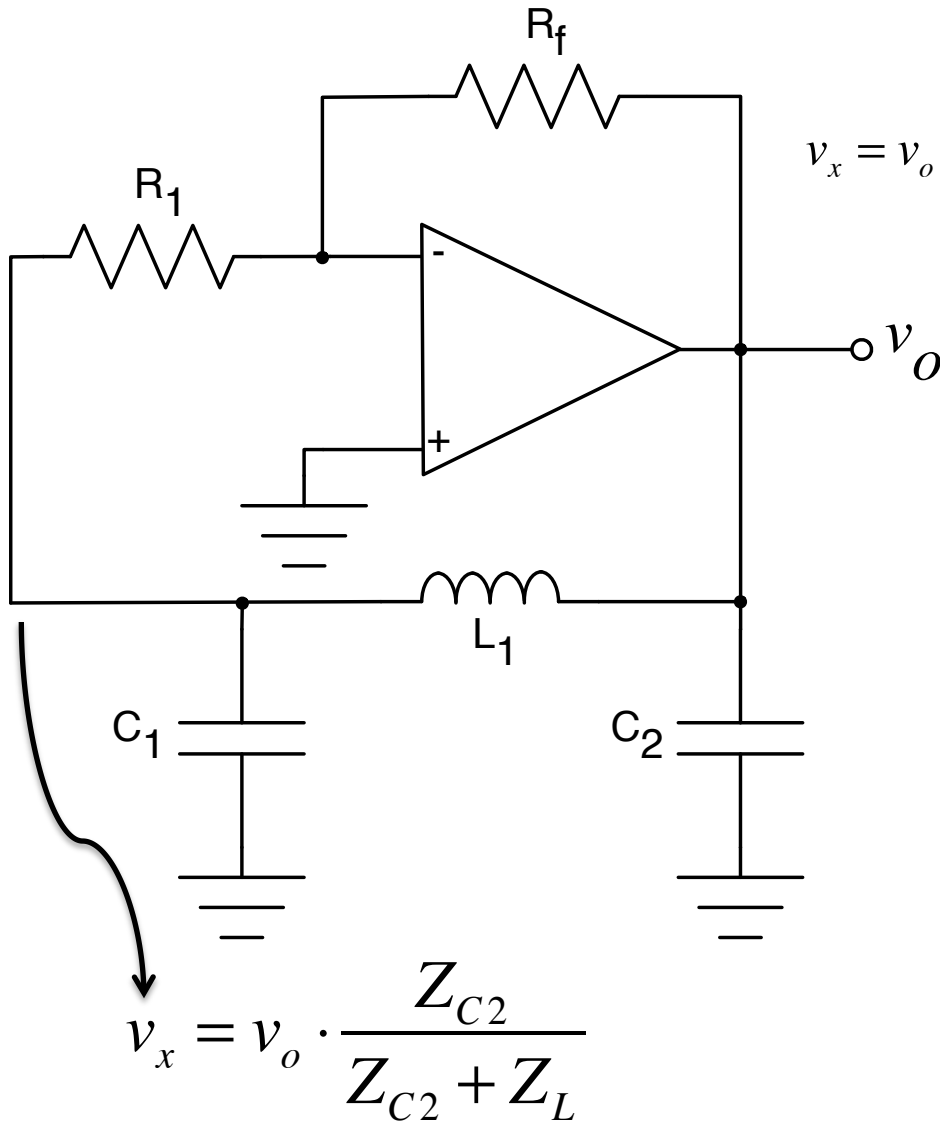

$$v_x = v_o \cdot \frac{\frac{1}{j \cdot \omega \cdot C_2}}{\frac{1}{j \cdot \omega \cdot C_2} + j \cdot \left( \frac{1}{\omega \cdot C_1} + \frac{1}{\omega \cdot C_2} \right)} = -v_o \cdot \frac{C_1}{C_2}$$

$$\beta = \frac{v_x}{v_o} = -\frac{C_1}{C_2}$$

$$|\alpha \cdot \beta| = 1$$

$$\alpha = \frac{C_2}{C_1}$$

$$\frac{R_f}{R_1} = \frac{C_2}{C_1}$$

# Oscilador Colpits com BJT

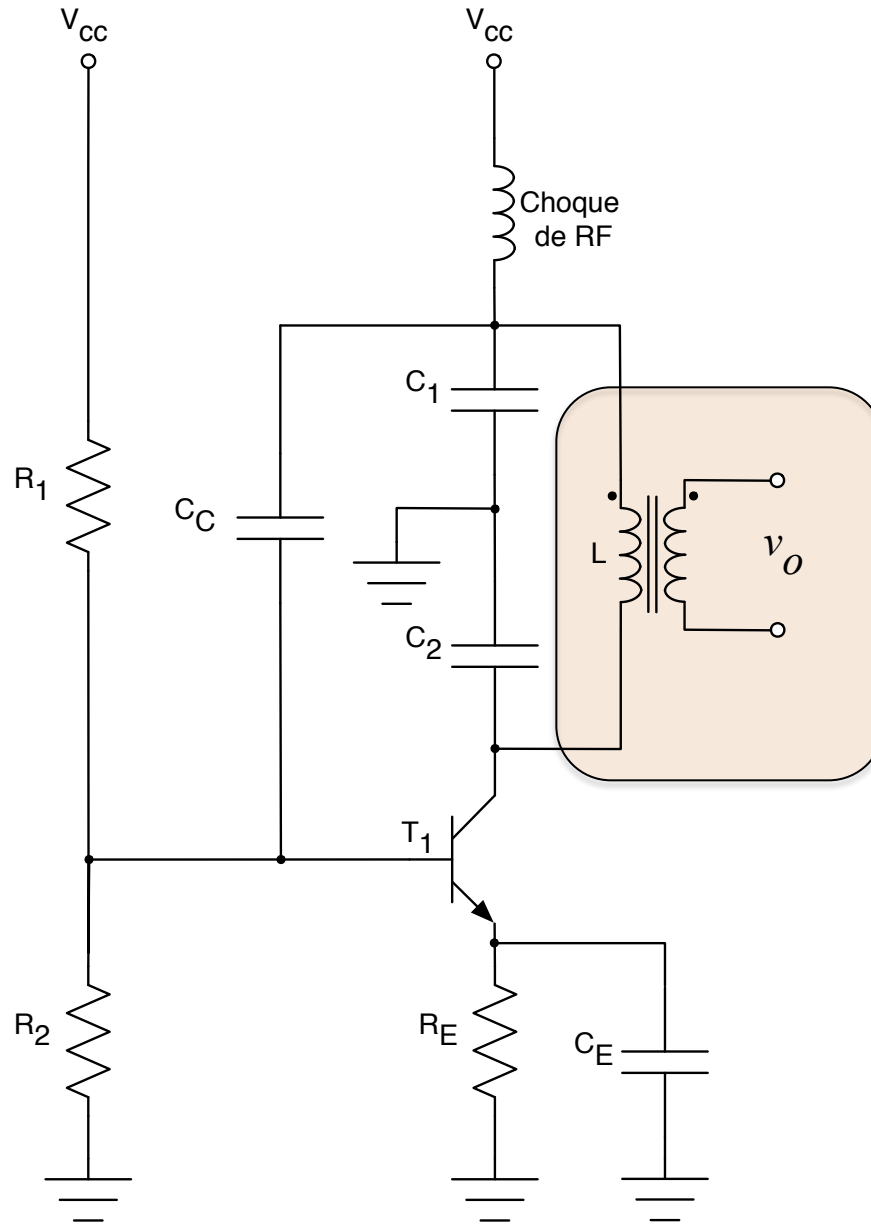

# Oscilador Colpitts com BJT

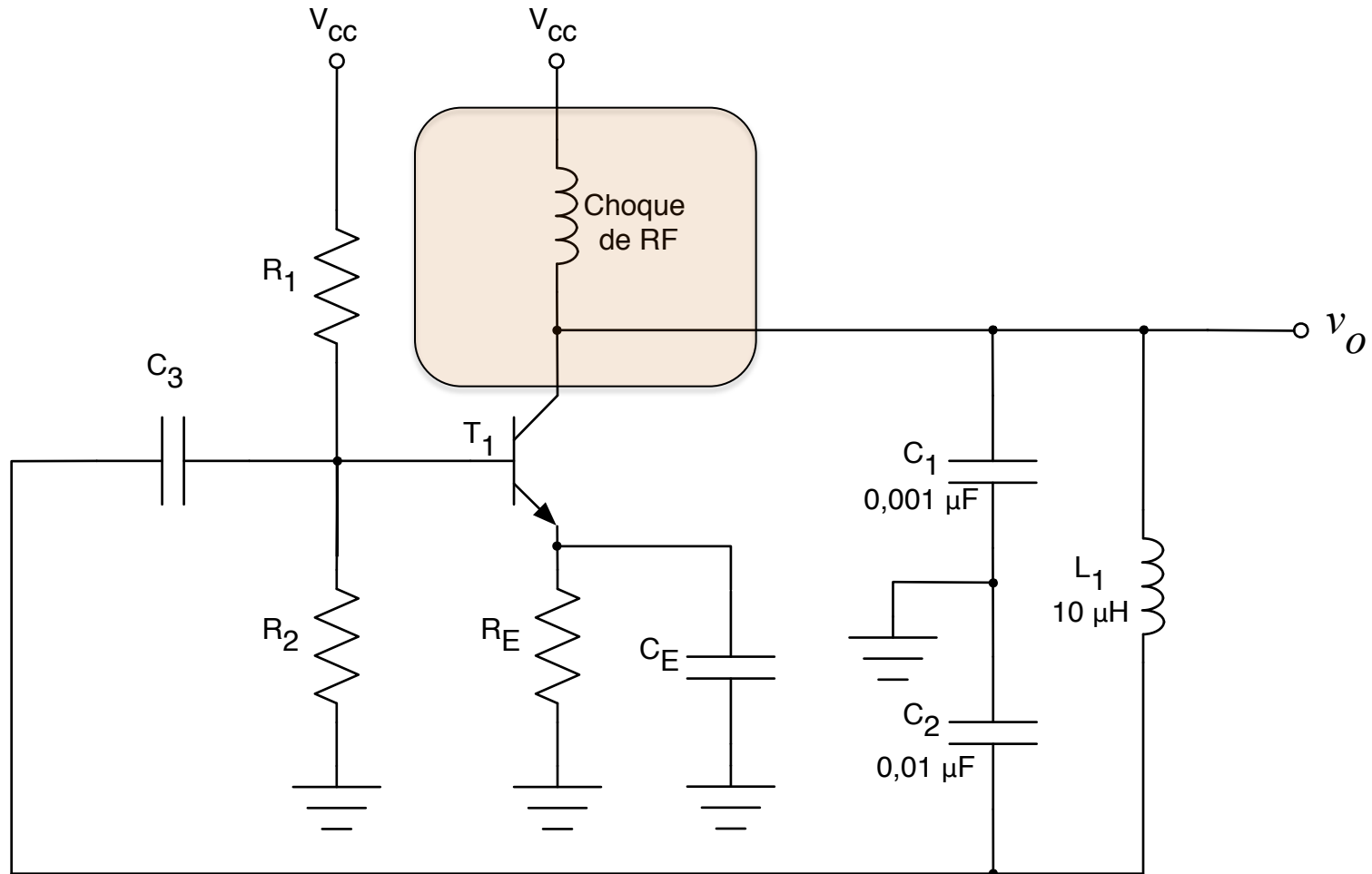

# Oscilador Colpits com BJT

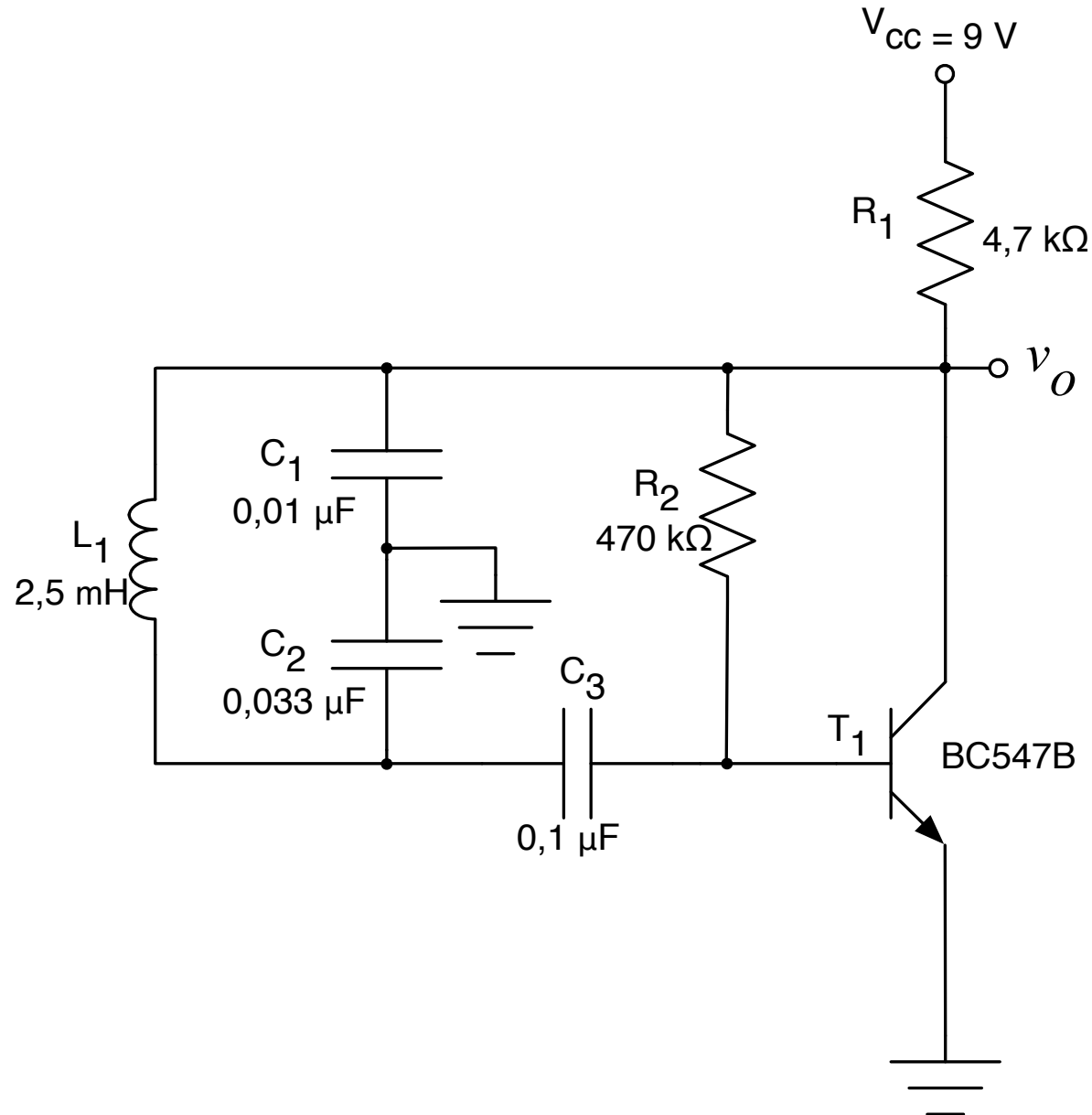

# Oscilador Colpits com BJT

Circuito de polarização:

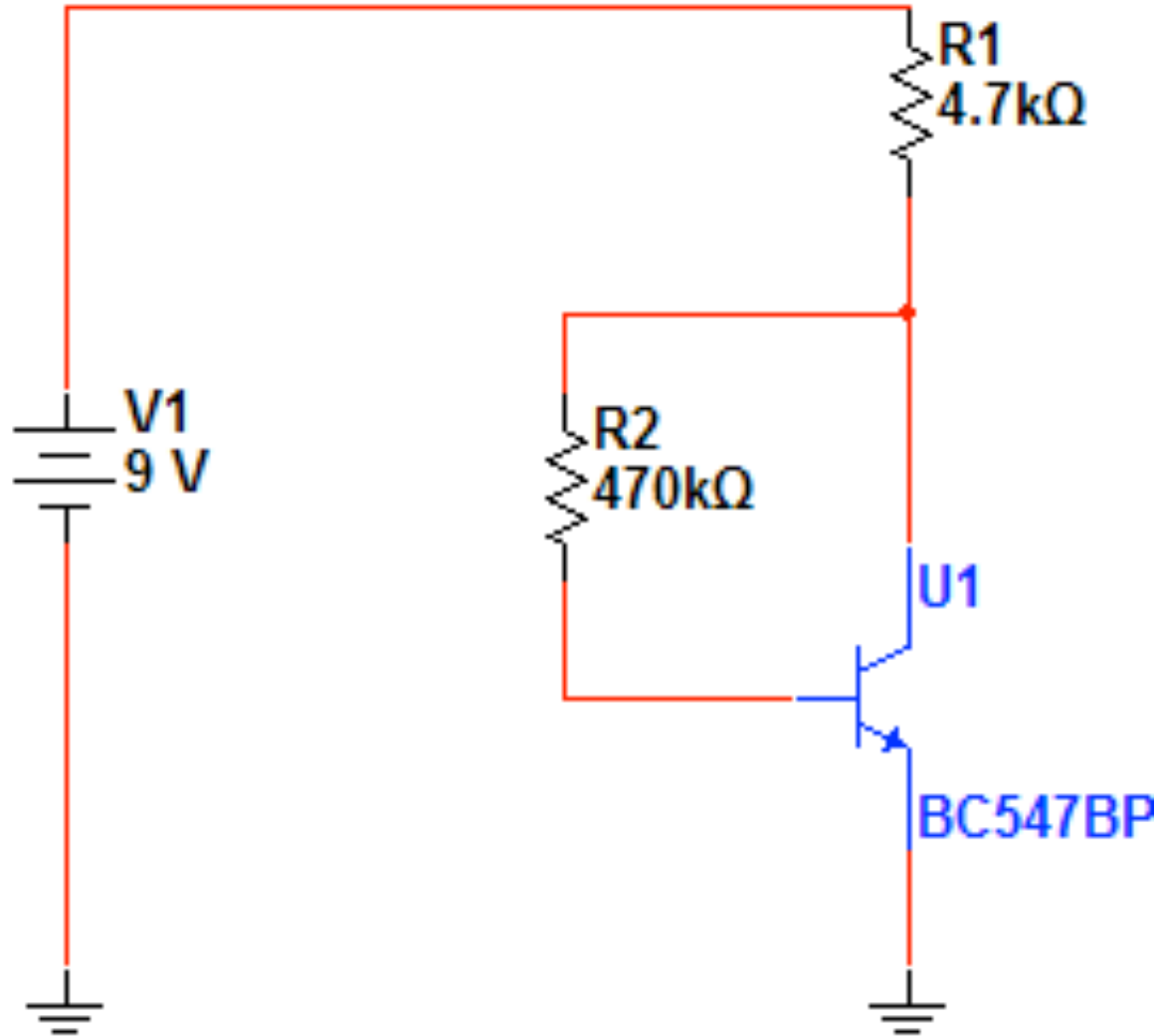

# Oscilador Colpits com BJT

## Circuito de polarização:

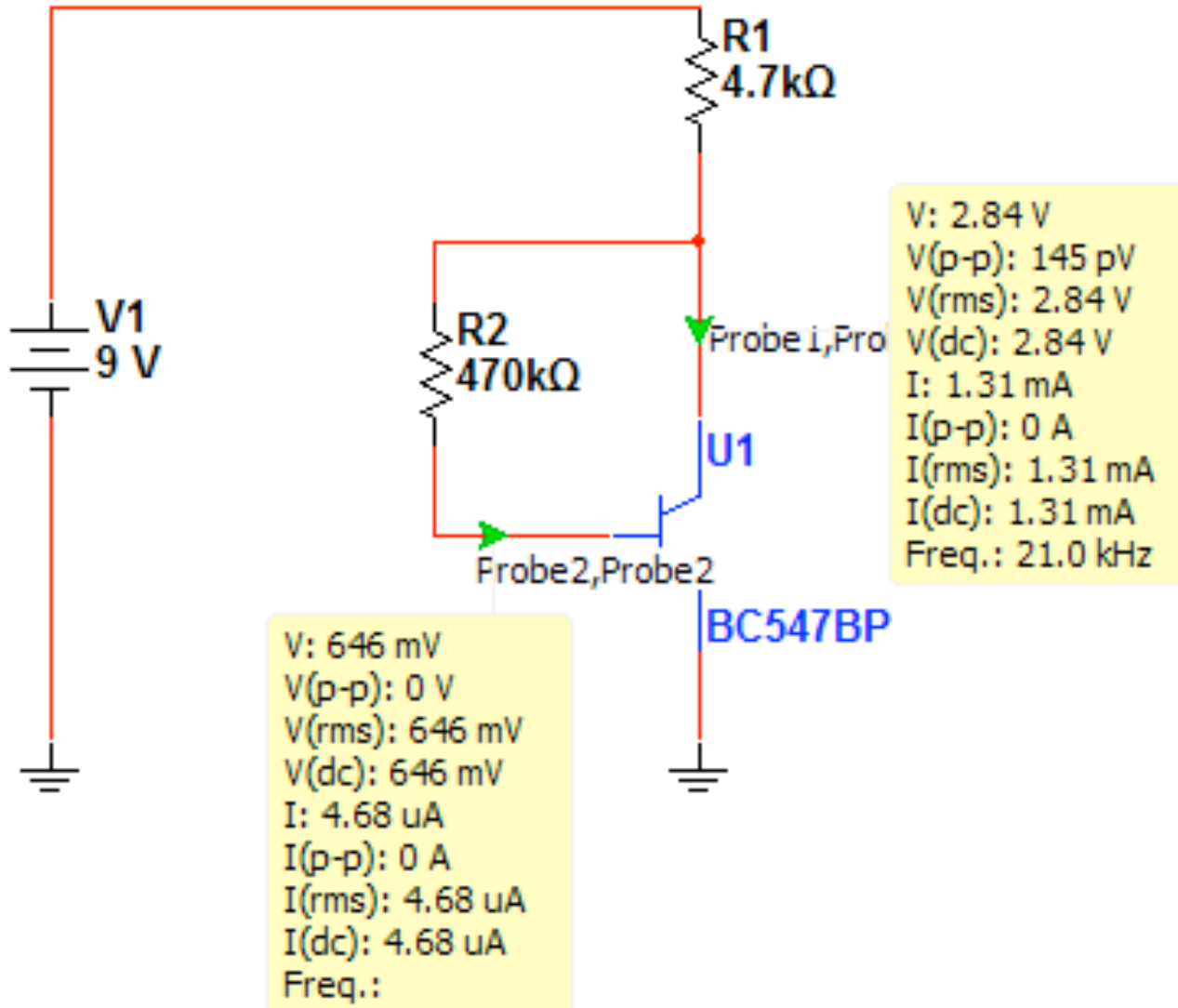

# Oscilador Colpits com BJT

Circuito para simulação:

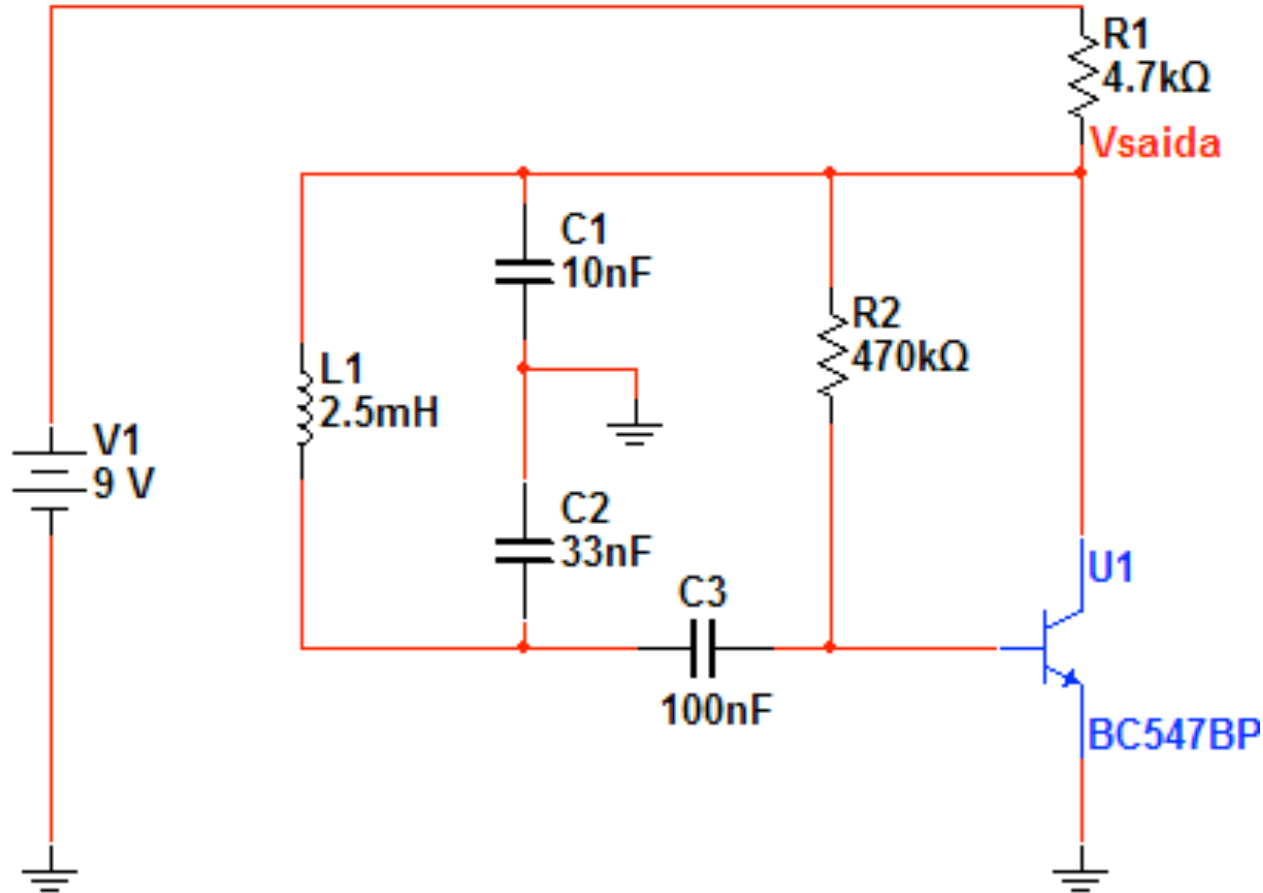

$$F_o = \frac{1}{2\pi \cdot \sqrt{2,5 \cdot 10^{-3} \cdot 0,0077 \cdot 10^{-6}}} \approx 36,3 \text{ kHz}$$

## Simulação do oscilador Colpitts:

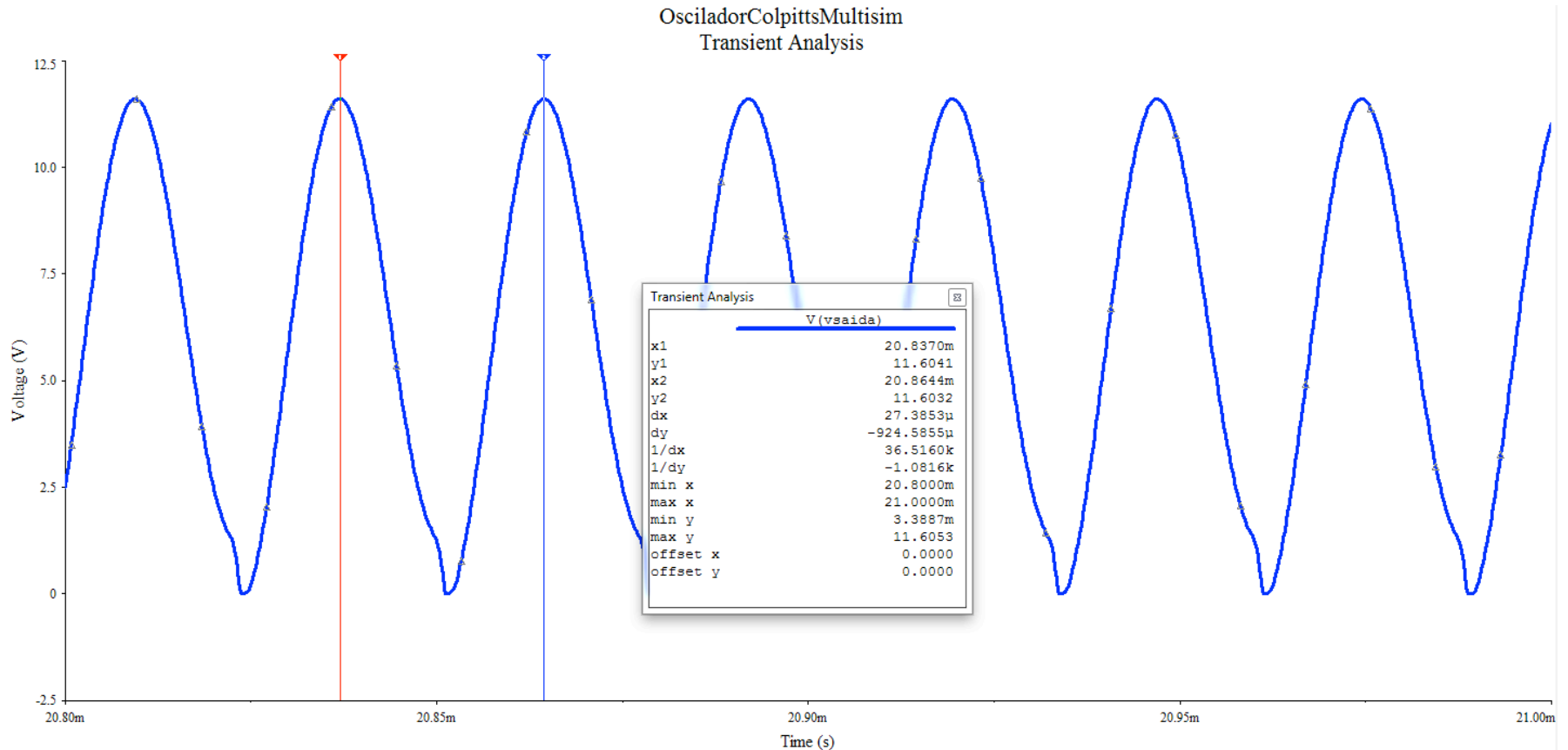

**Precisa de ajustes no ganho.**

## Simulação do oscilador Colpits:

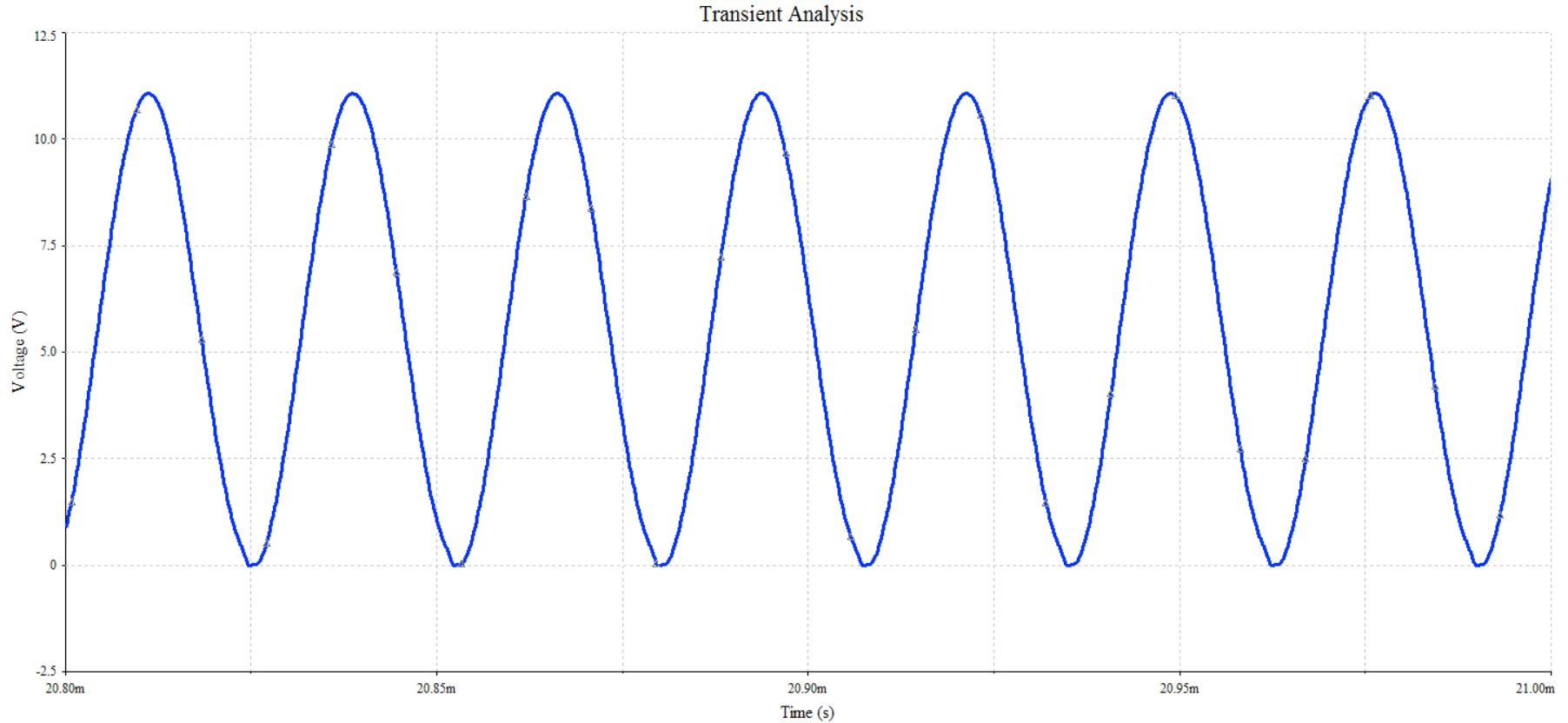

$$F_o \approx 36,516 \text{ kHz}$$



# Oscilador Clapp com AmpOp

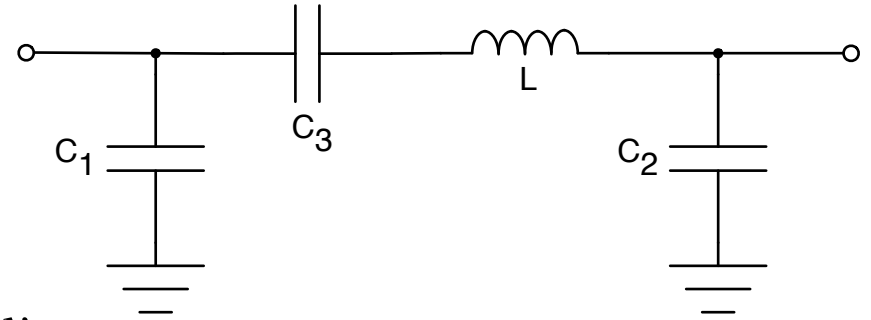
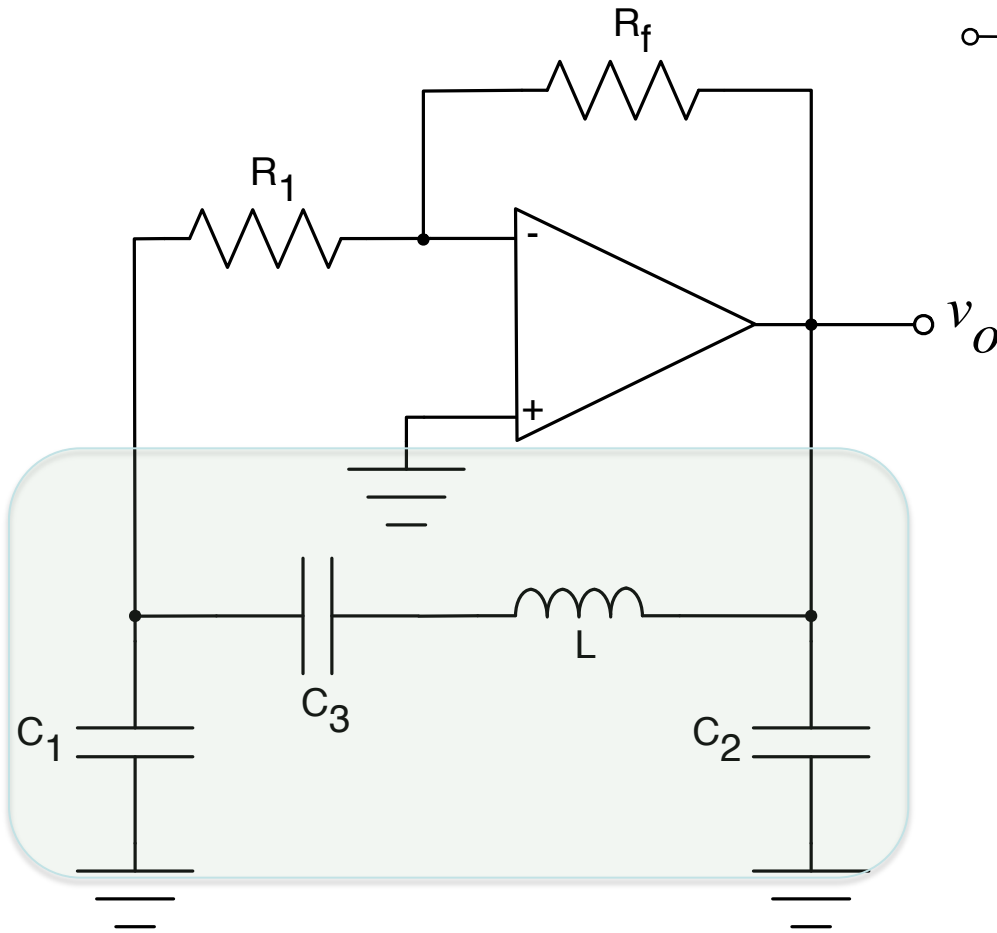

$$Z = \frac{C_3 - C_2 \cdot (-1 + C_3 \cdot L_1 \cdot \omega^2)}{j \cdot (C_2 \cdot C_3 + C_1 \cdot (C_2 + C_3 - C_2 \cdot C_3 \cdot L_1 \cdot \omega^2))}$$

$$\omega = \frac{1}{\sqrt{L_1 \cdot C_T}}$$

$$\frac{1}{C_T} = \frac{1}{C_1} + \frac{1}{C_2} + \frac{1}{C_3}$$

$$F_o = \frac{1}{2\pi \cdot \sqrt{L \cdot C_T}}$$

# Oscilador Clapp com AmpOp

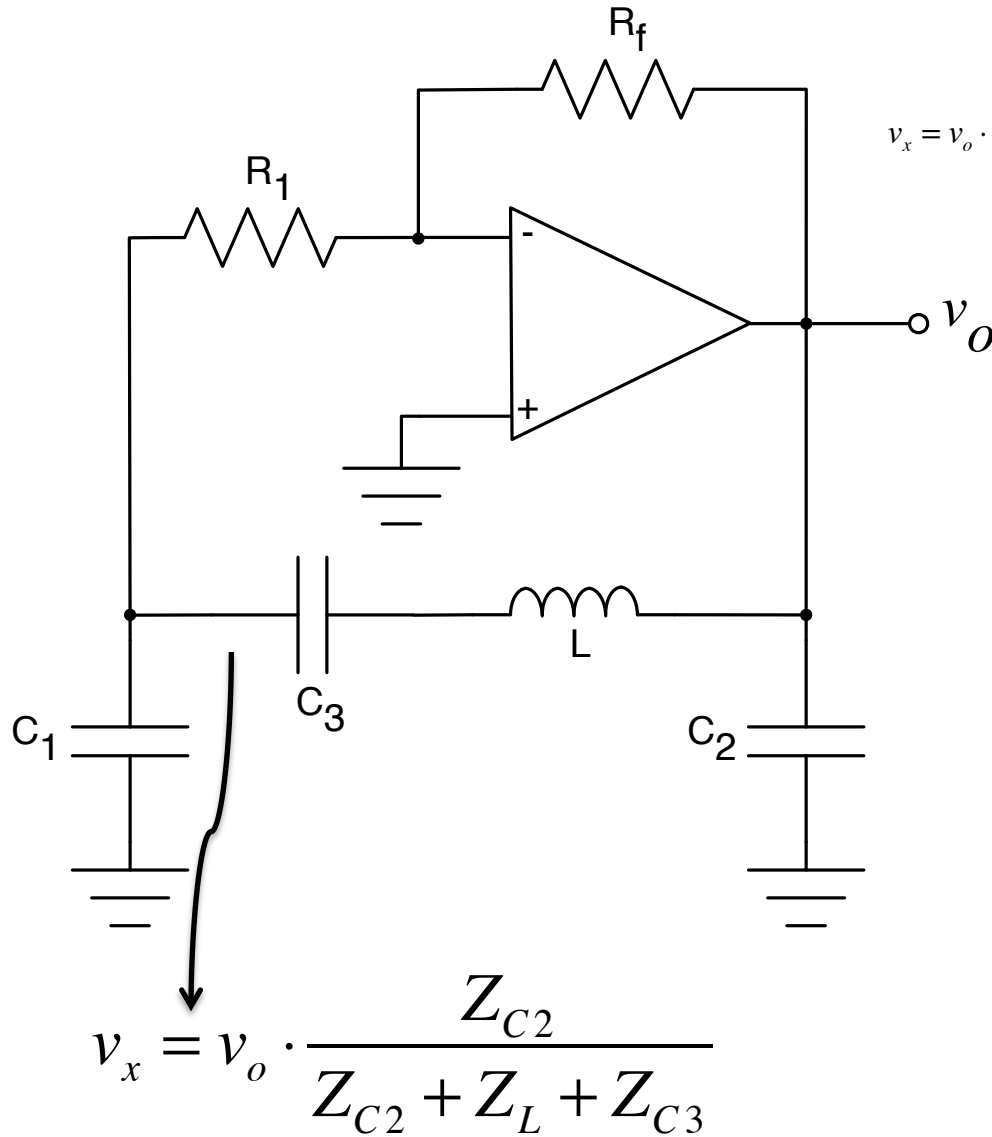

$$v_x = v_o \cdot \frac{\frac{1}{j \cdot \omega \cdot C_2}}{\frac{1}{j \cdot \omega \cdot C_2} + j \cdot \left( \frac{1}{\omega \cdot C_1} + \frac{1}{\omega \cdot C_2} + \frac{1}{\omega \cdot C_3} \right) + \frac{1}{j \cdot \omega \cdot C_3}} = -v_o \cdot \frac{C_1}{C_2}$$

$$\beta = \frac{v_x}{v_o} = -\frac{C_1}{C_2}$$

$$|\alpha \cdot \beta| = 1$$

$$\alpha = \frac{C_2}{C_1} \quad |\alpha| = \frac{R_f}{R_1}$$

$$\frac{R_f}{R_1} = \frac{C_2}{C_1}$$

# Oscilador Clapp com BJT

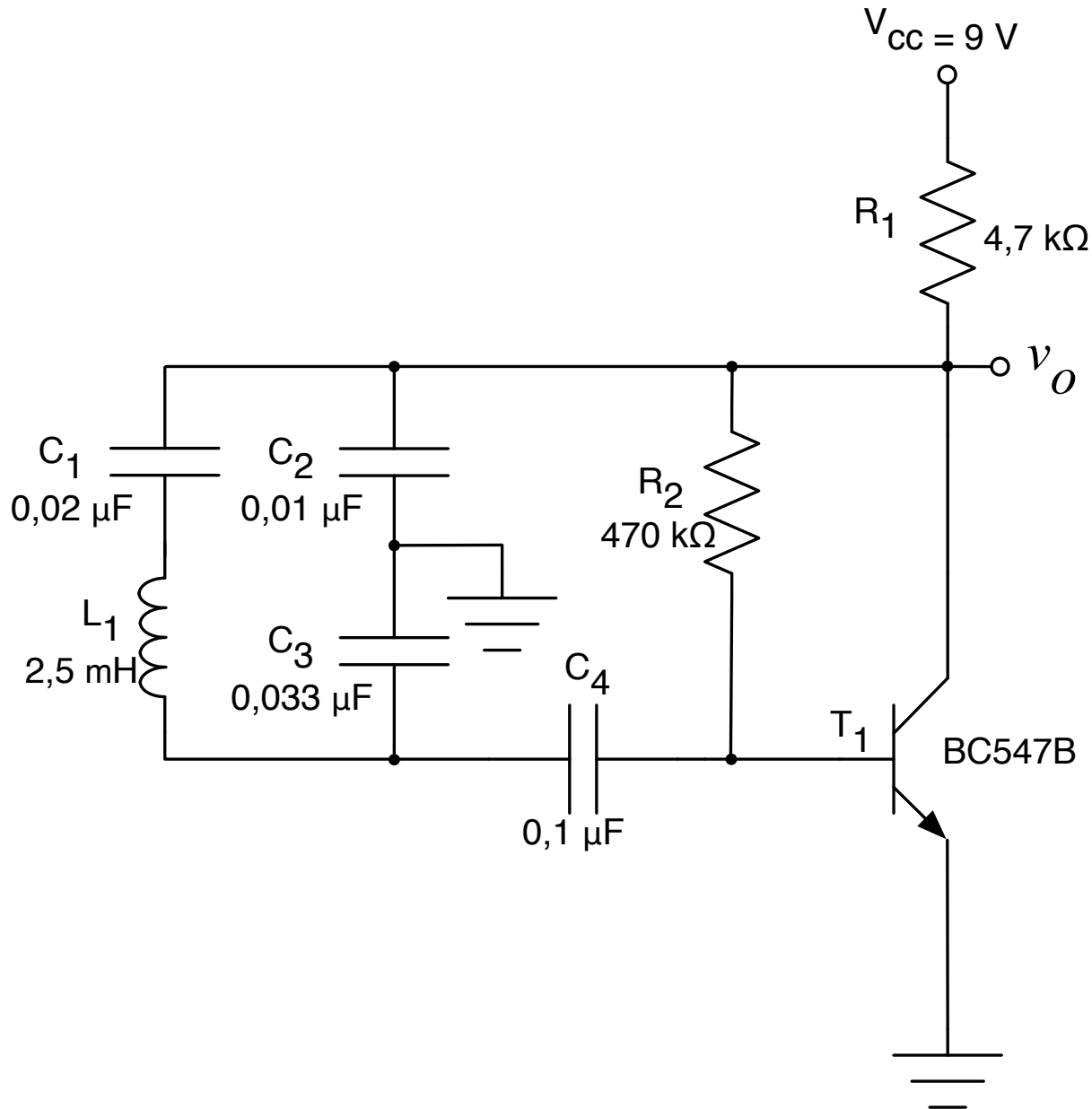

# Oscilador Clapp com BJT

Circuito de polarização:

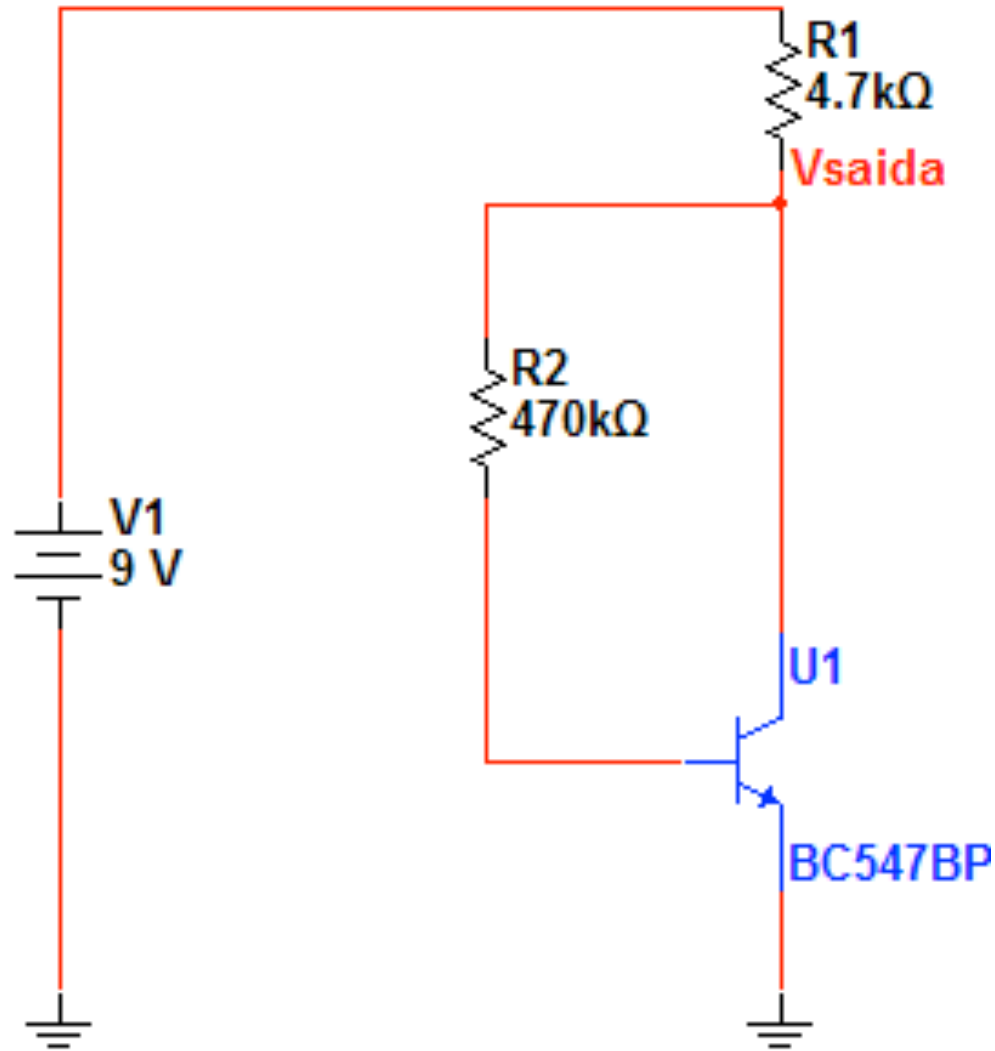

# Oscilador Clapp com BJT

## Circuito de polarização:

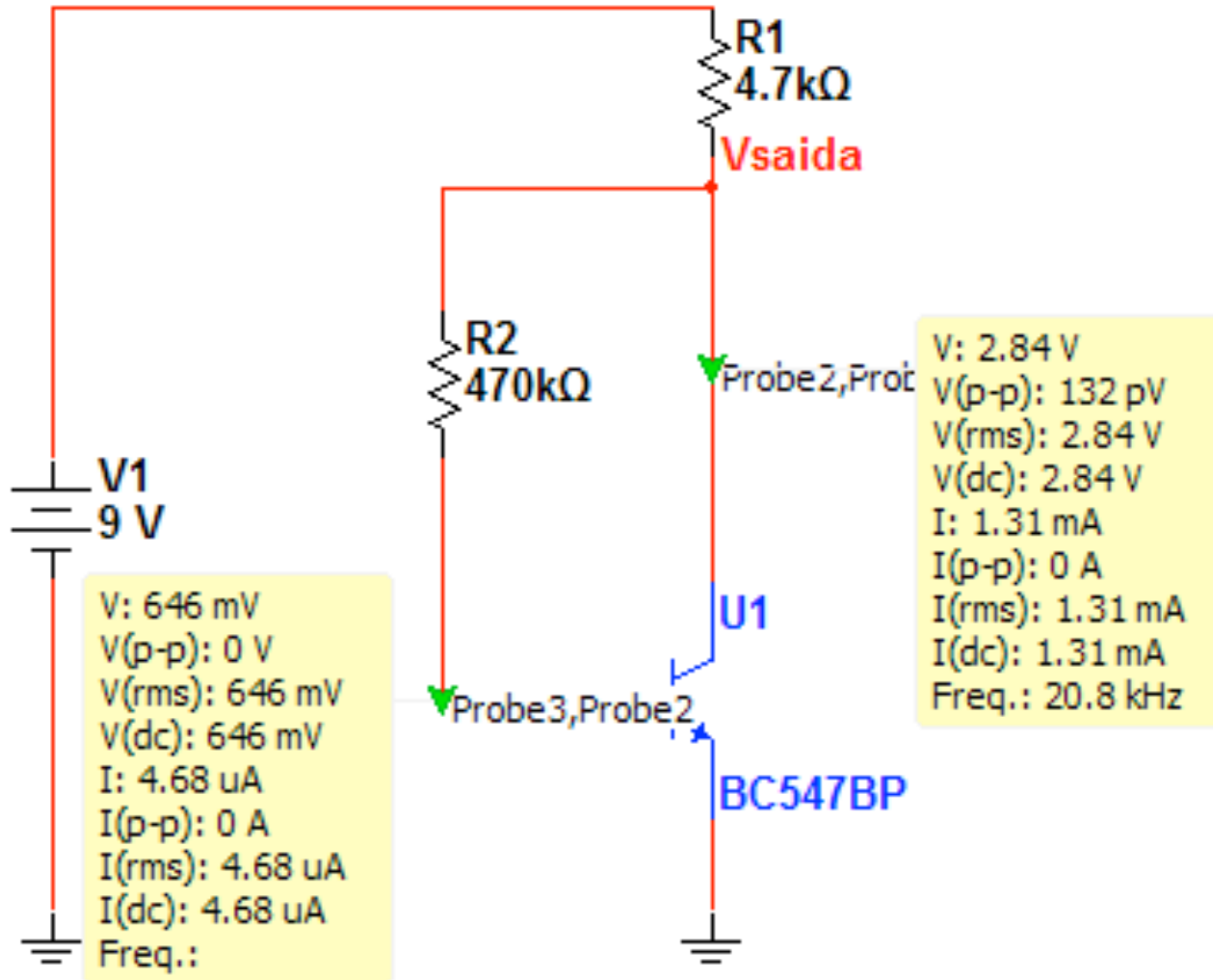

# Oscilador Clapp com BJT

Circuito para simulação:

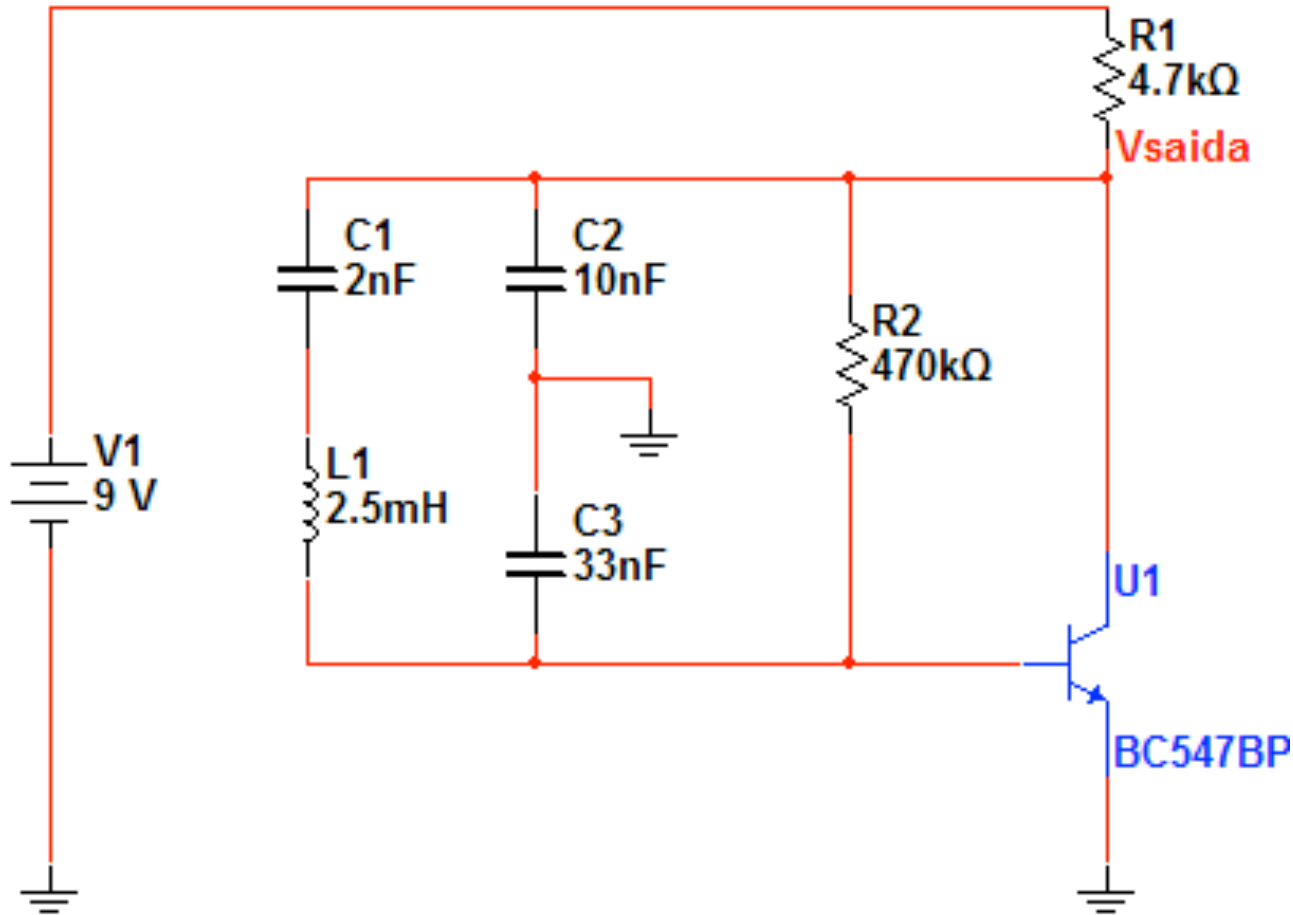

$$F_o = \frac{1}{2\pi \cdot \sqrt{2,5 \cdot 10^{-3} \cdot 1,59 \cdot 10^{-9}}} \approx 80 \text{ kHz}$$

## Simulação do oscilador Clapp:

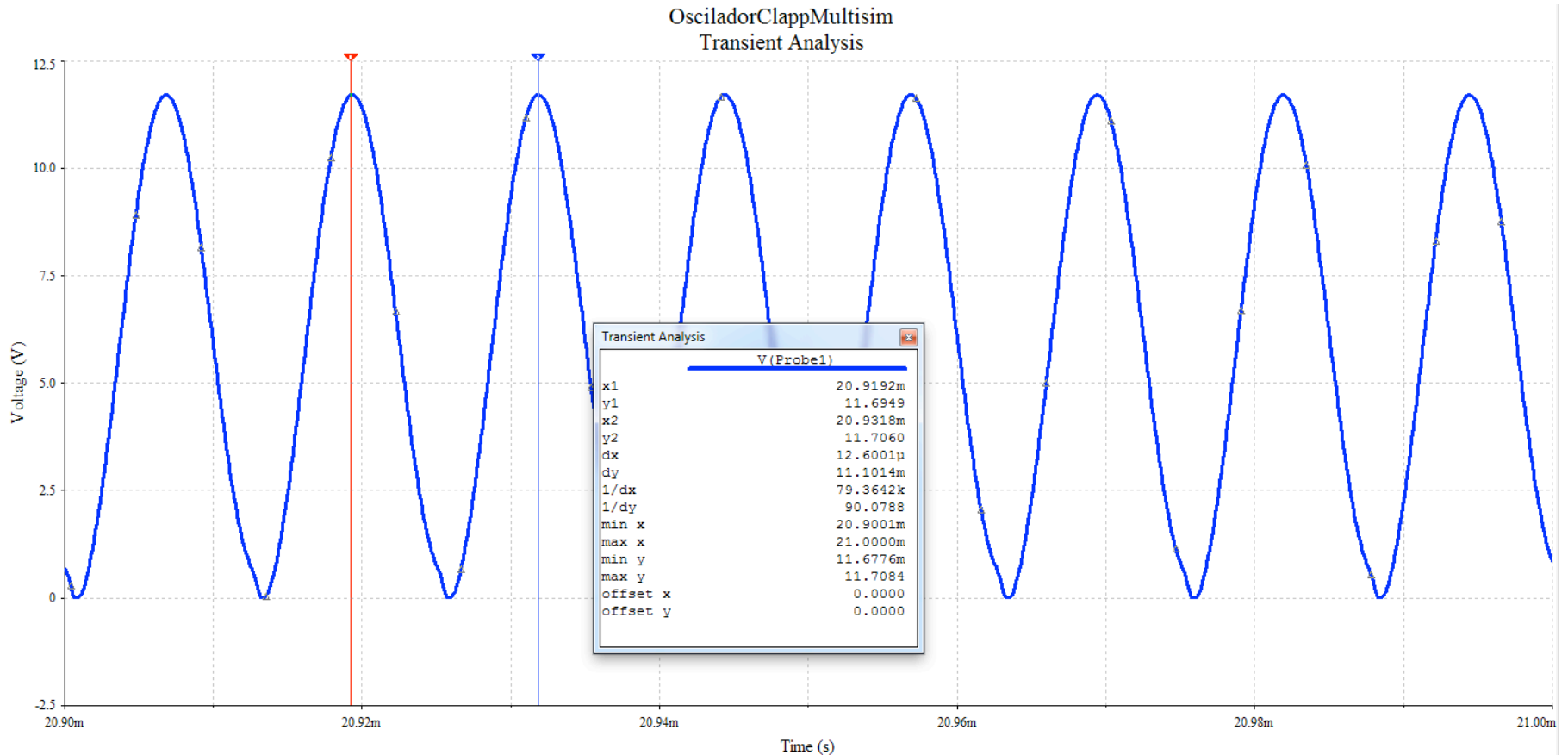

**Precisa de ajustes no ganho.**

## Simulação do oscilador Clapp:

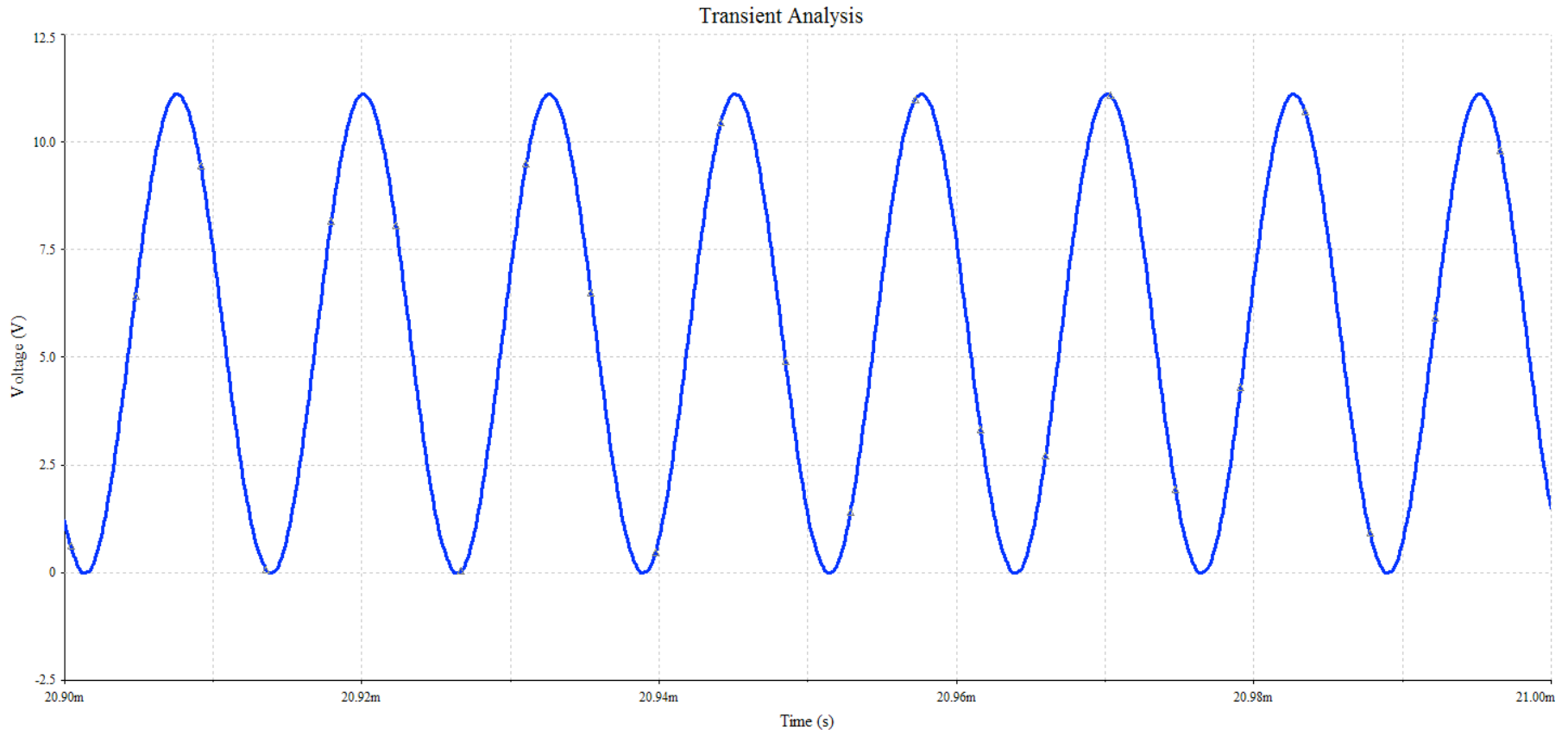

$$F_o \approx 79,3642 \text{ kHz}$$

# Oscilador Hartley com AmpOp

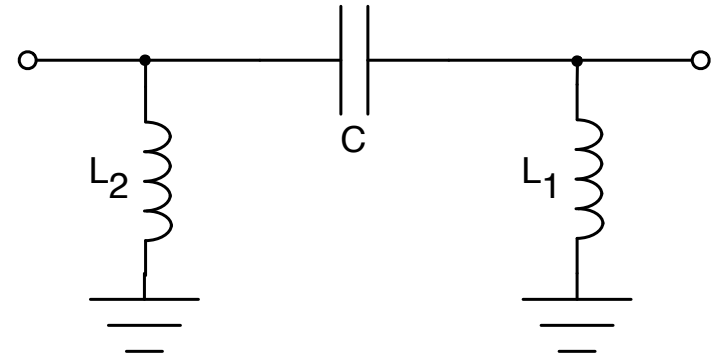
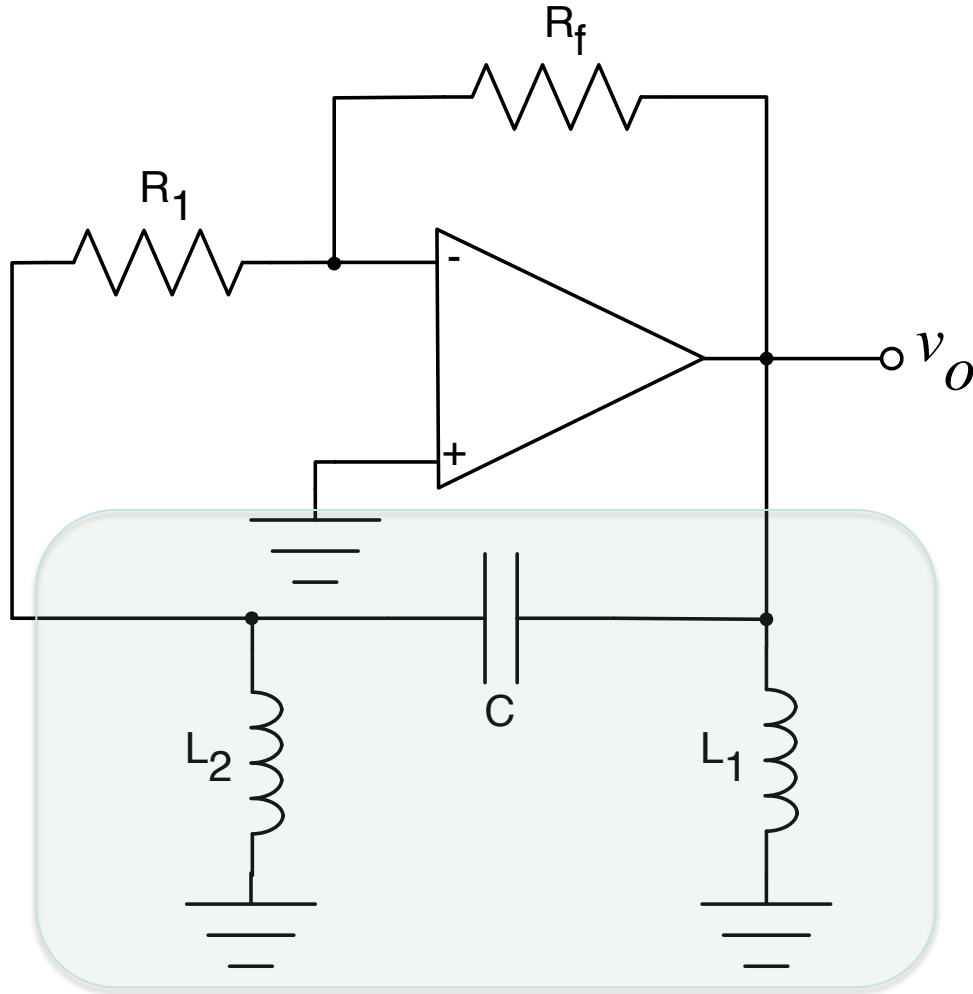

$$Z = \frac{L_1 \cdot \omega \cdot (C_1 \cdot L_2 \cdot \omega^2 - 1)}{j \cdot (1 - C_1 \cdot (L_1 + L_2) \cdot \omega^2)}$$

$$\omega = \frac{1}{\sqrt{L_T \cdot C}}$$

$$L_T = L_1 + L_2$$

$$F_o = \frac{1}{2\pi \cdot \sqrt{L_T \cdot C}}$$



# Oscilador Hartley com BJT

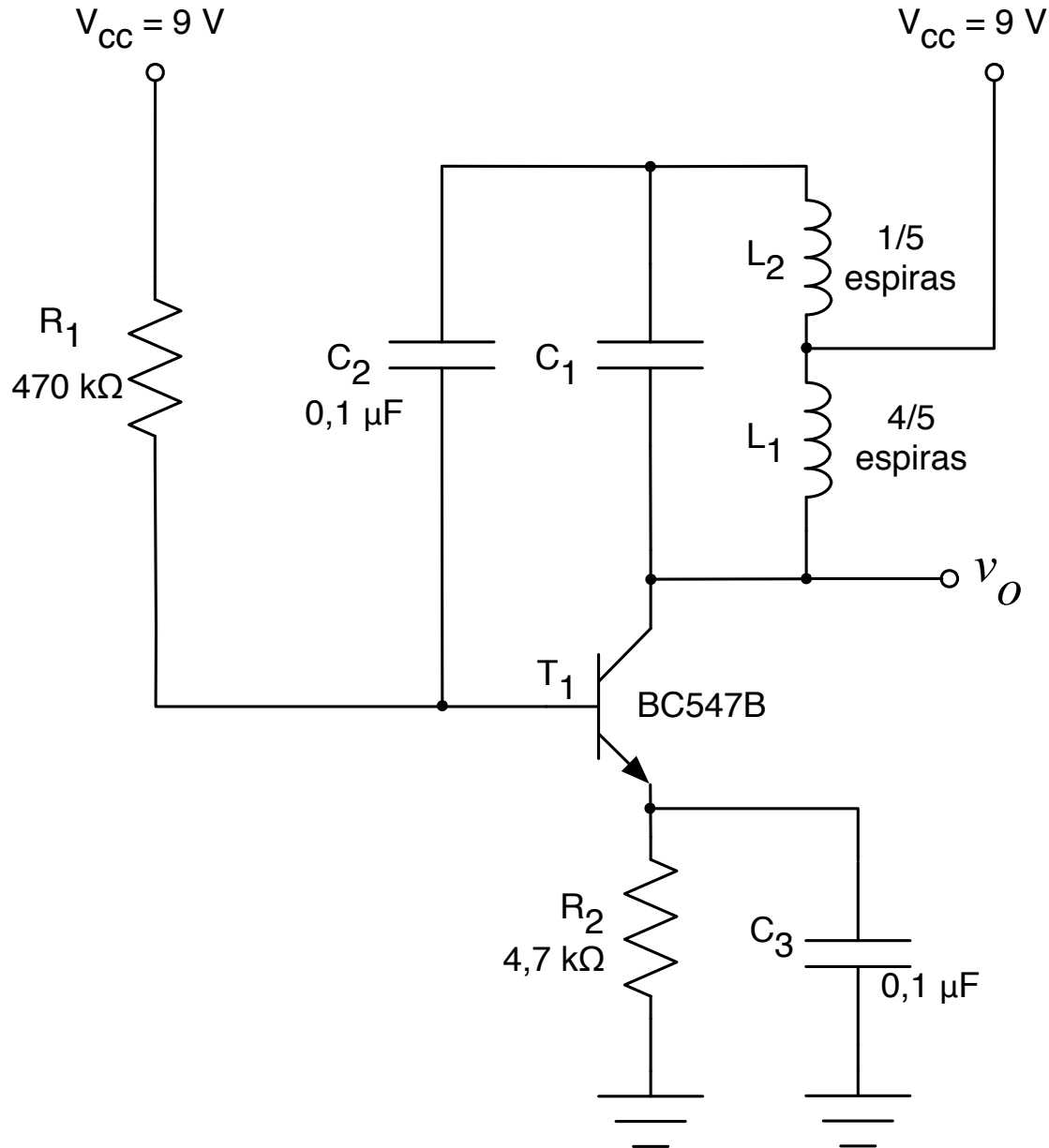

# Oscilador Hartley com BJT

Circuito de polarização:

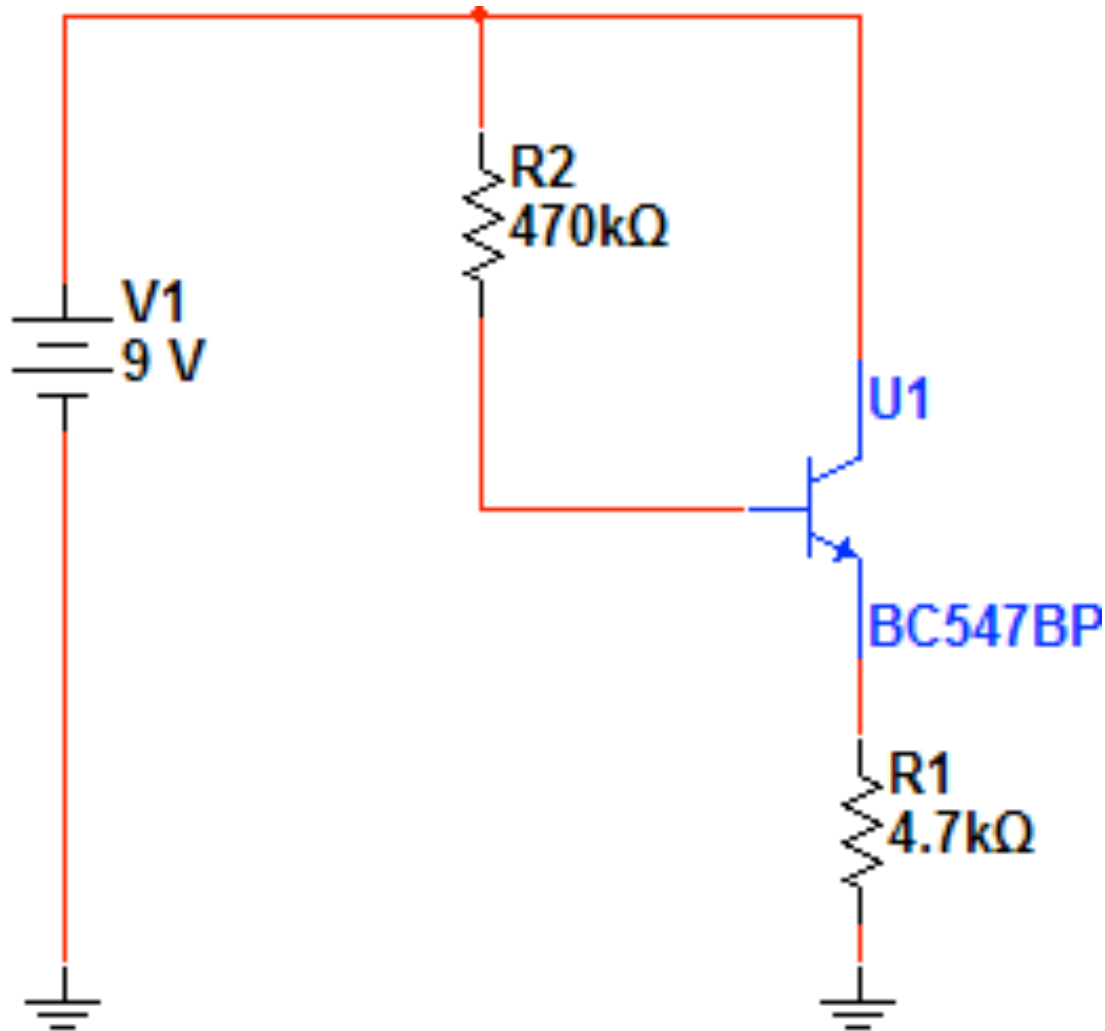



# Oscilador Hartley com BJT

Circuito de polarização:

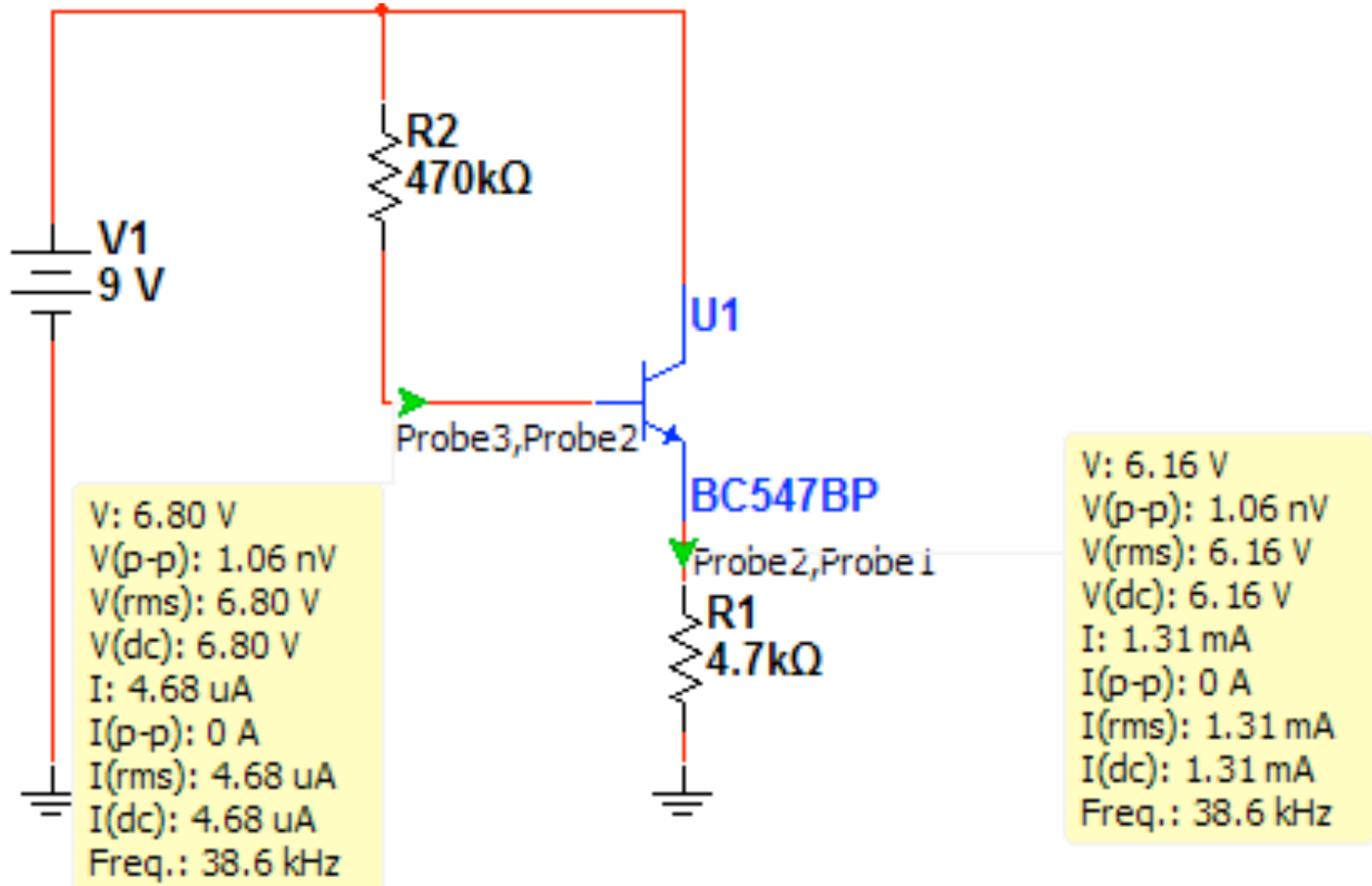

# Oscilador Hartley com BJT

Circuito para simulação:

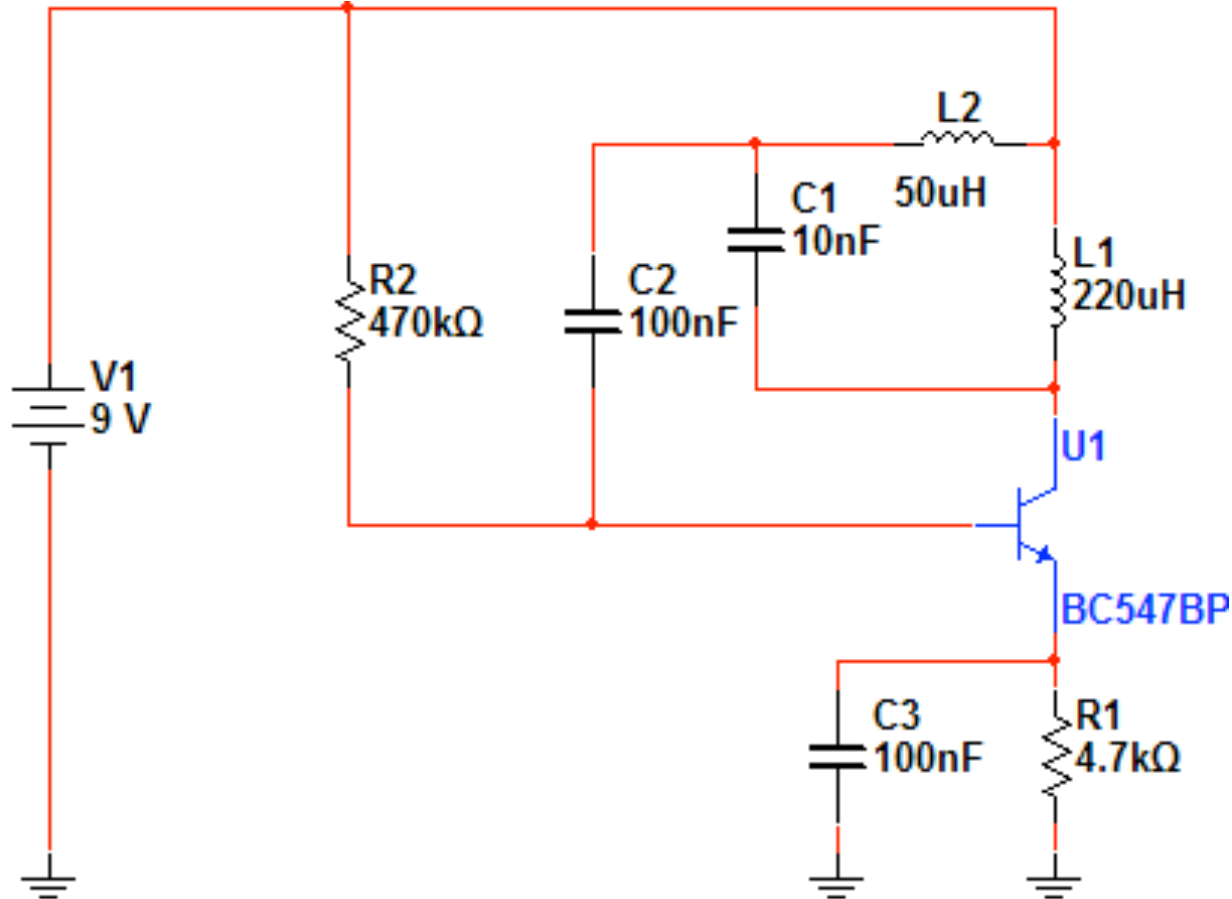

$$F_o = \frac{1}{2\pi \cdot \sqrt{220 \cdot 10^{-6} \cdot 10 \cdot 10^{-9}}} \approx 96,86 \text{ kHz}$$

## Simulação do oscilador Hartley:

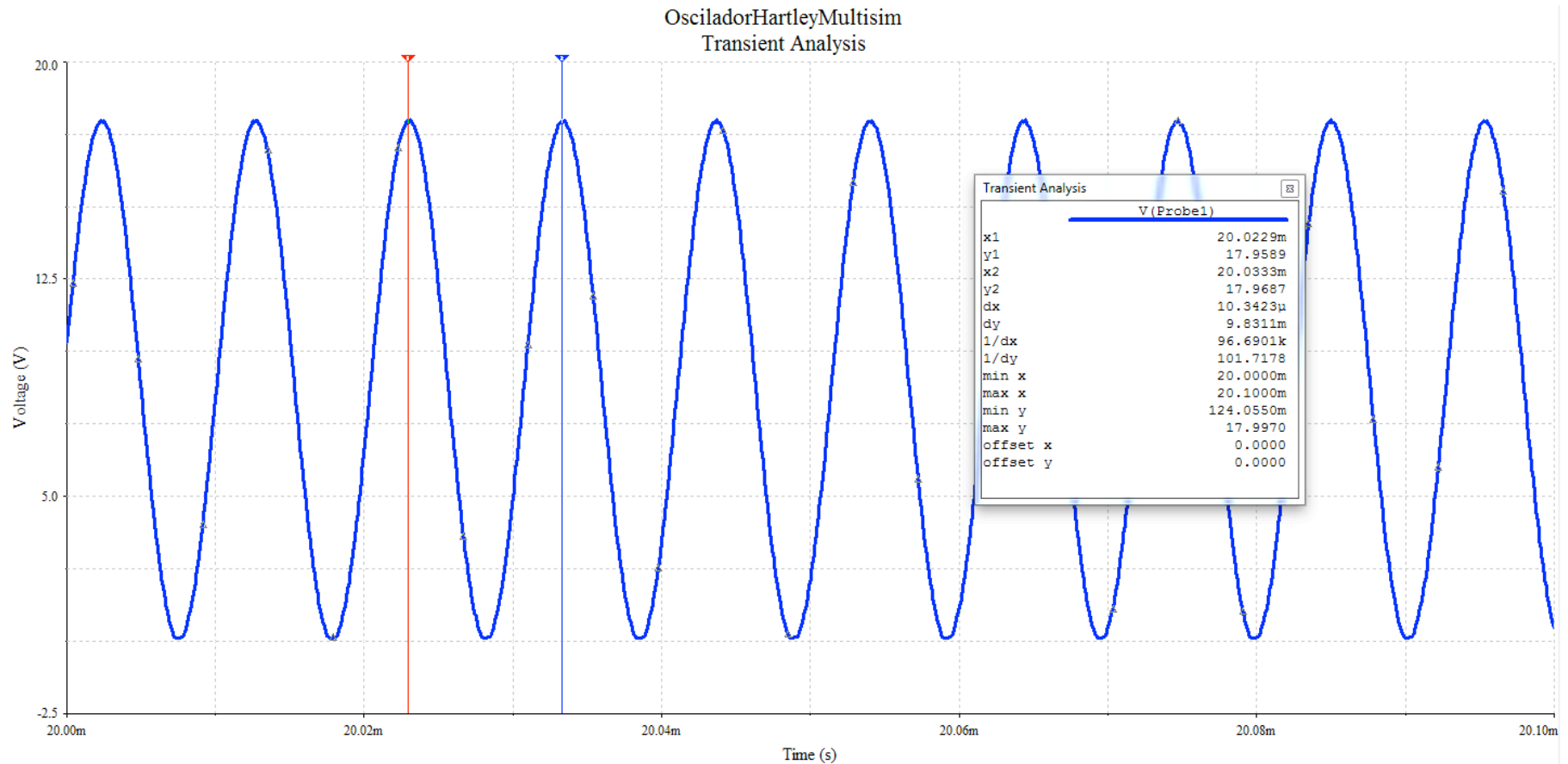

**Precisa de ajustes no ganho.**

# Oscilador Armstrong com BJT

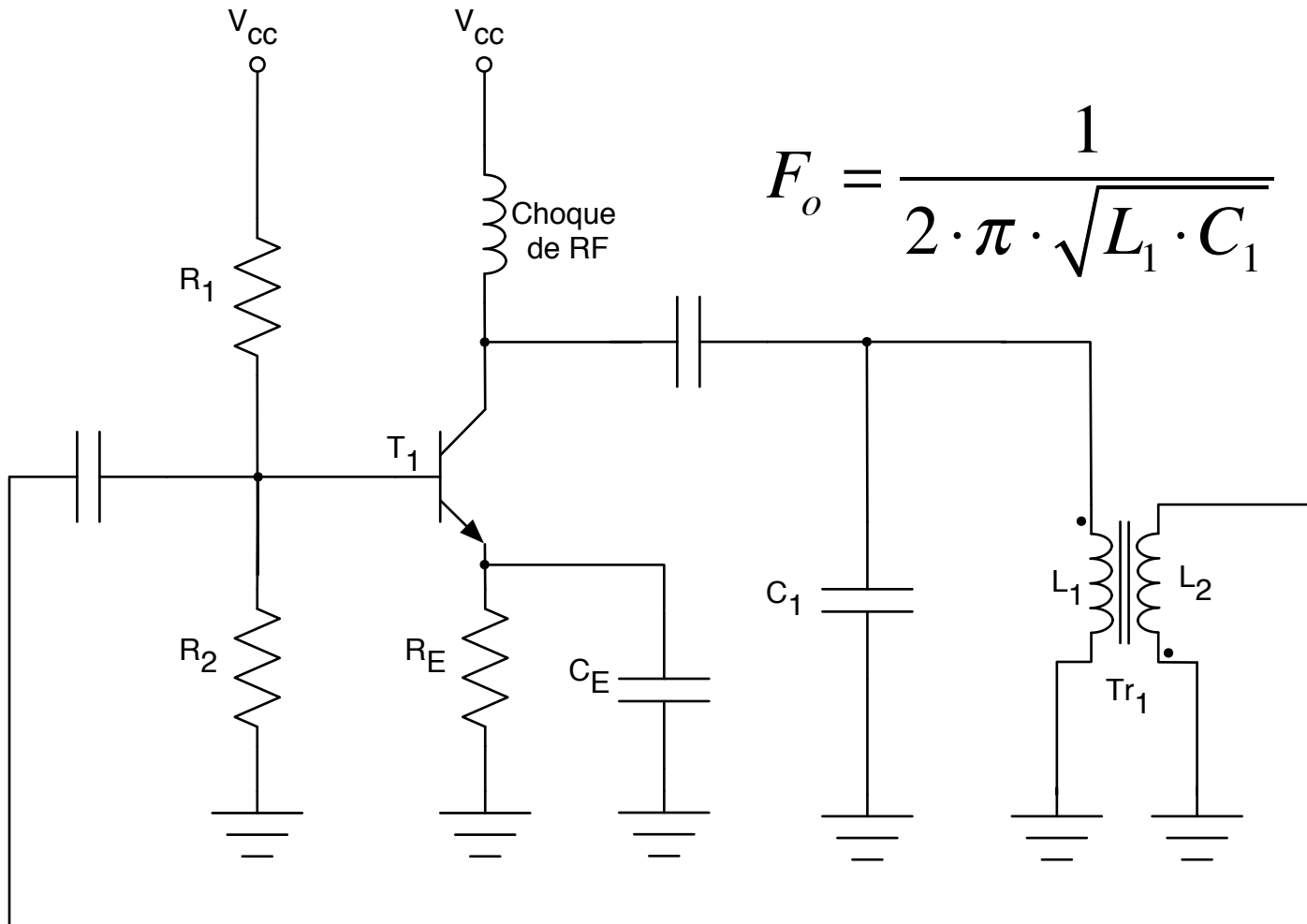

$$M = \pm k \cdot \sqrt{L_1 \cdot L_2}$$

$$\beta = \frac{M}{L_1}$$

$$\alpha = \frac{L_1}{M}$$

# Oscilador Armstrong com BJT

Circuito de polarização:

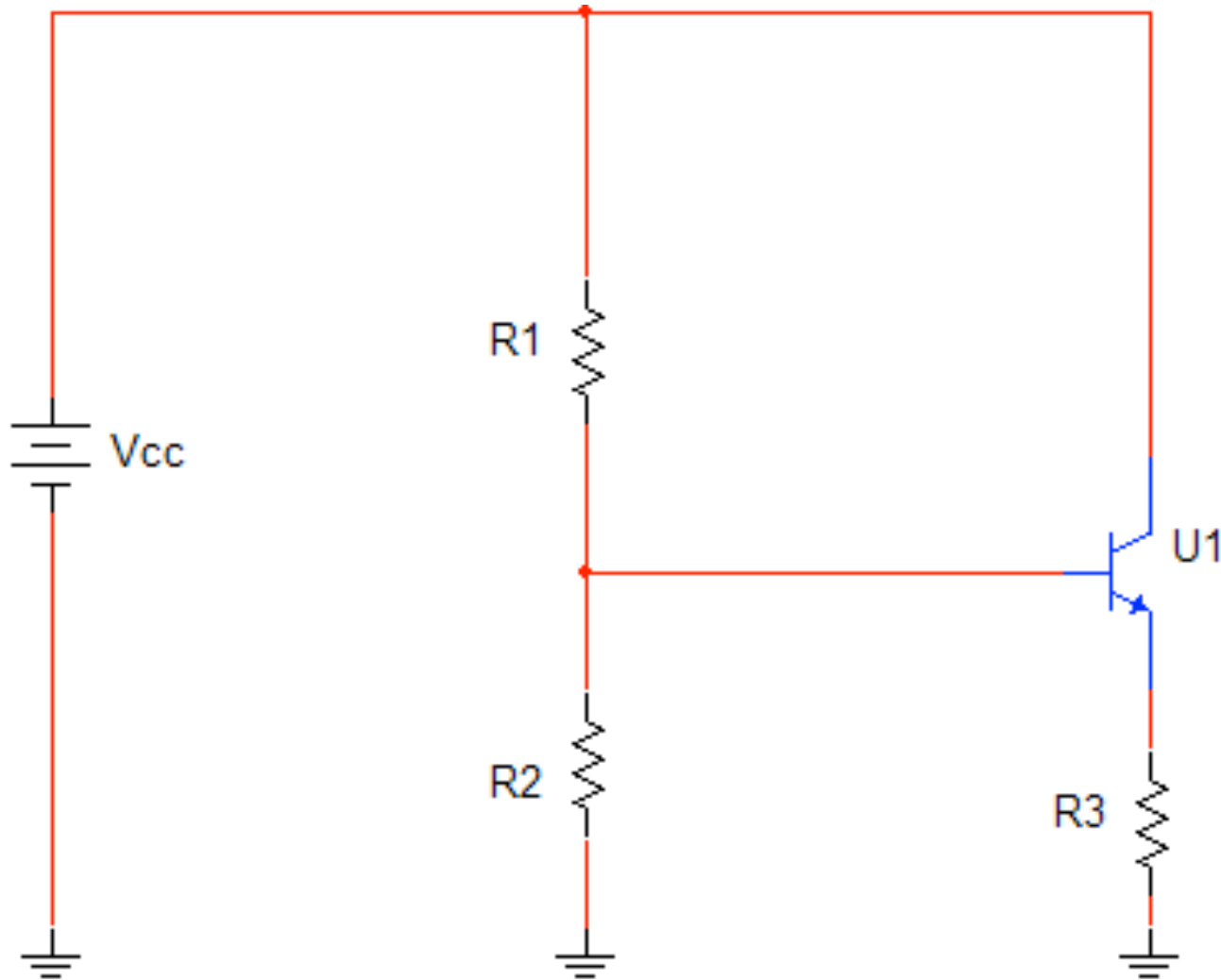



# Oscilador Armstrong com BJT

## Circuito de polarização:

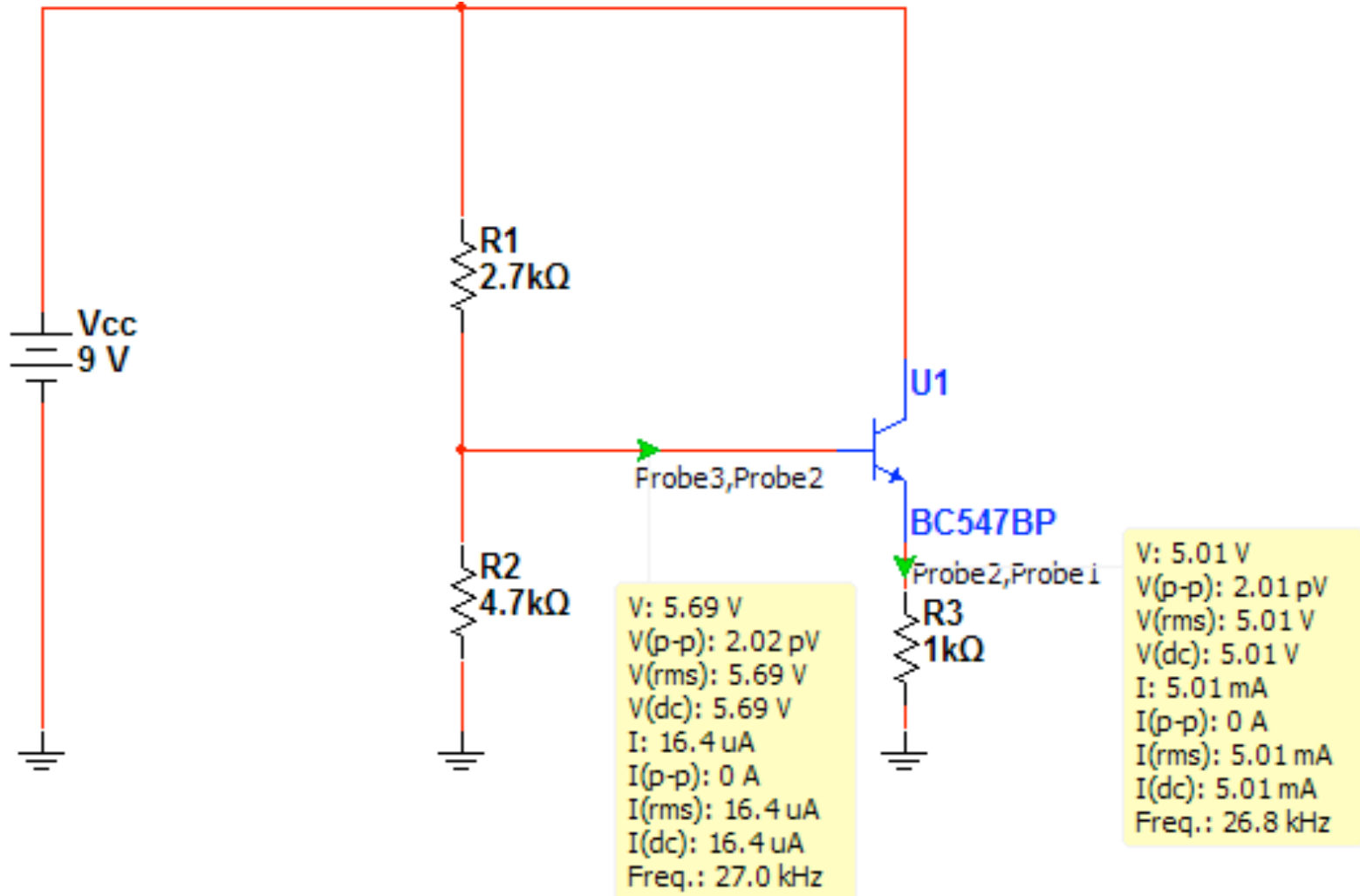



# Oscilador Armstrong com BJT

Circuito para simulação:

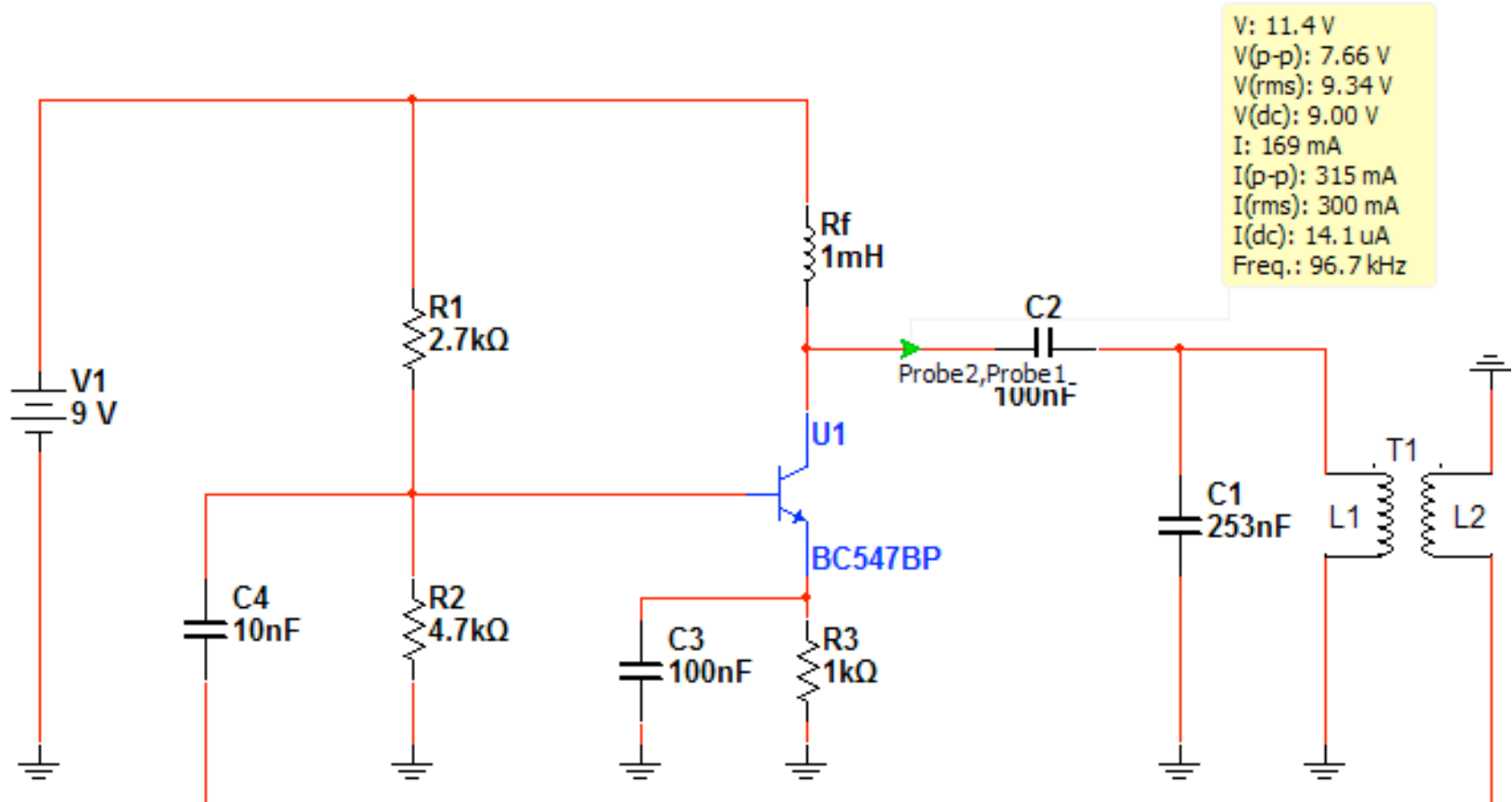

## Simulação do oscilador Armstrong:

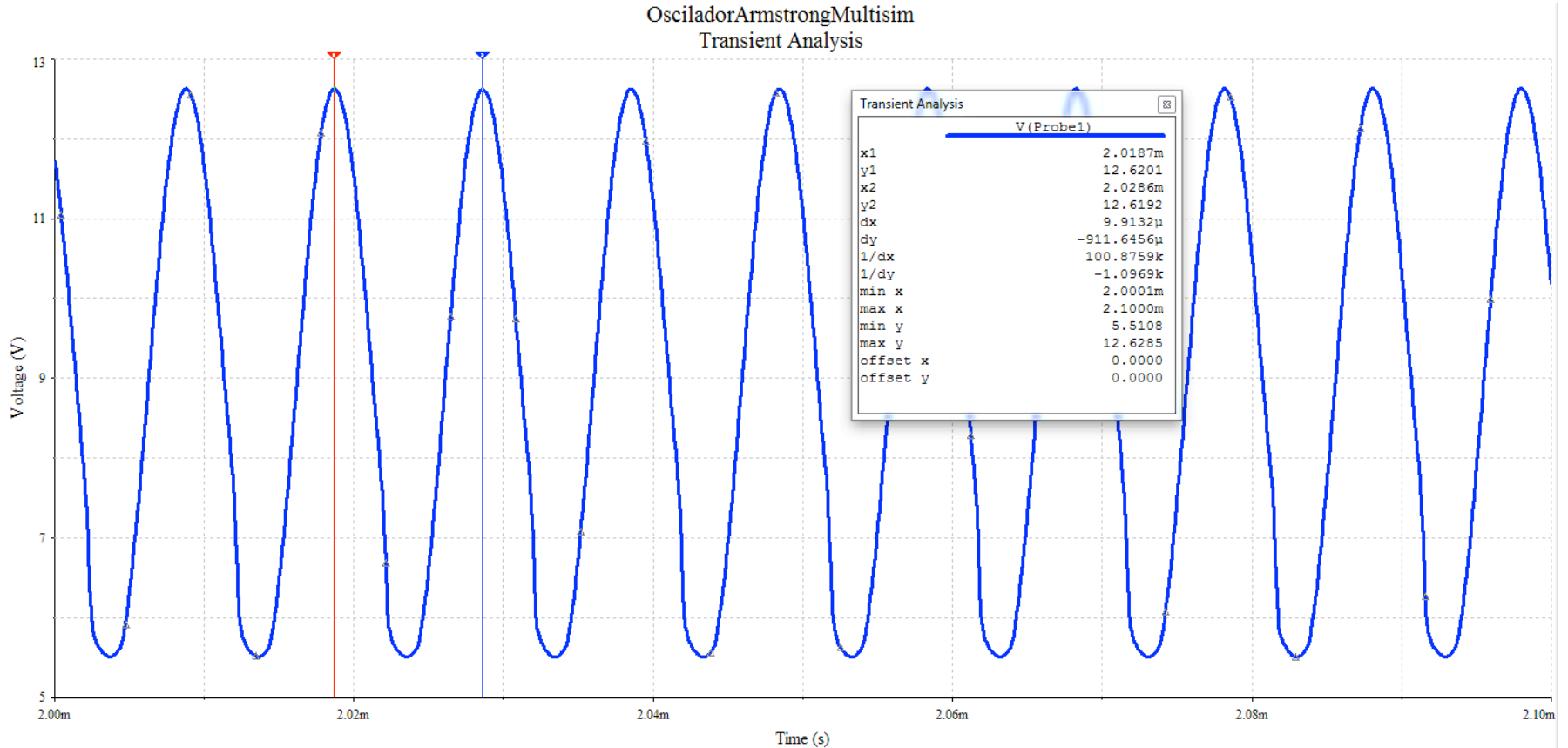

## Exercícios de osciladores sintonizados.

