

Application Note **AN-7002**

Revision:	00
Issue Date:	2006-09-05
Prepared by:	Pramod Bhosale Markus Hermwille

Key Words: IGBT driver, connection, controller, IGBT

www.Semikron.com/Application/DriverConnection

Connection of Gate Drivers to IGBT and Controller

This application note provides information on the connection of the gate driver to the controller and IGBT modules. This information should help minimize malfunctions in the gate driver and IGBT module caused by electromagnetic interference, signal oscillation or

induced noise. The information given in this application note contains tips only and does not constitute complete design rules; the information is not exhaustive. The responsibility for proper design remains with the user.

Connection between gate driver and controller

Control signals for the gate driver should not be compromised by interference. Electrical interference can arise for a number of reasons, one of them being high di/dt and dv/dt as a result of IGBT switching.

Theoretically, no induction from other signals should influence the control signals, as this may cause malfunction. In practice, however, this is not possible to achieve. That said, cables should be routed properly to reduce any such effects to a minimum. A few design tips for gate driver / controller connection are given below.

- Tracks on the printed circuit board should be kept as short as possible. Loops should be avoided.
- Length of cable should be as short as possible and should not exceed three metres. Twisted pair cable should be used.
- Control signals (low-power signal) are not to be grouped with high-power signals (power supply). Use signal ground and power supply ground separately. Both should be tied at one point only (in most cases at the driver) to avoid looping.
- Signal cable should be placed as far away as possible from power terminals, power cables, ground cables, DC-link capacitors and all other noise sources.
- Control signal cable should not run parallel to power cable. The minimum distance between control signal cable and power cable should be 30cm and the cables should cross vertically only.
- It is recommended that all cables be kept close to ground (e.g. heat sink or the likes).
- In noise intensive applications, it is recommended that shielded cables or fibre optic interfaces be used to improve noise immunity.
- Use a low value capacitor (1nF) between signal and power supply ground of the gate driver for differential-mode noise suppression.
- The use of an open collector drive is not recommended.

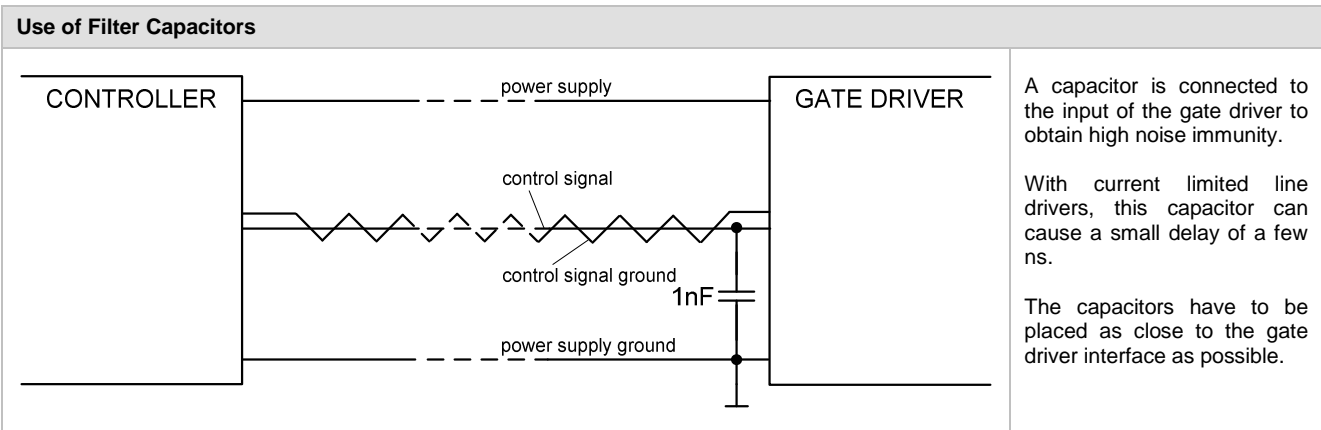

Connection between gate driver and IGBT module

The gate driver must be located very close to the IGBT module to minimize stray inductance between the gate driver and IGBT module. An advantageous solution, even

for high-power IGBT modules, is to mount the gate driver onto the IGBT module directly.

Gate driver SKYPER 32 mounted directly on top of SEMiX IGBT module

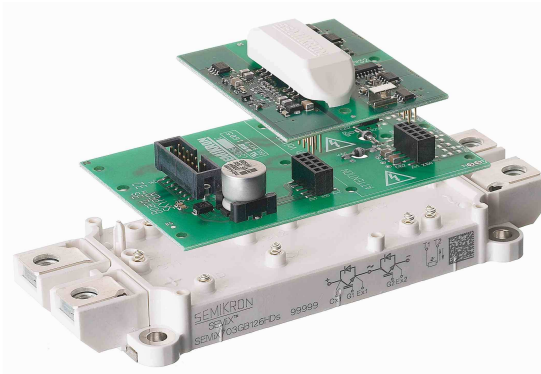

Besides reliable electric circuits for driver and monitoring functions, another key requirement for power electronic systems is to provide an optimum connection between gate driver and power module. In conventional solutions, drivers and power modules are connected by wires that are as short and as low-inductive as possible and twisted pair. Due to design restrictions, however, an optimum connection is not always possible. Complex wiring, as well as solder and plug-in connections are the result.

A connection that does not require soldering and complex wiring would allow for the development and production of solutions in which the gate driver can be reliably connected to the power semiconductors and the gate driver connected at any stage of the manufacturing process. A fast and easy way of achieving this is to use the standard gate driver SKYPER, an application-specific adapter board and the IGBT module SEMiX. Unlike integrated power modules (IPM), this solution offers electrical design flexibility.

With the SEMiX IGBT module, the adapter board and gate driver are mounted directly on the top of the power module, in doing so keeping the connection paths as short and reliable as possible. This type of connection requires no soldering owing to spring-based connecting technology. The adapter board, which is adapted to meet the requirements of the individual application and the IGBT module used, is screwed onto the SEMiX module. The springs, integrated in the module, provide the connection through solder pads on the bottom side of the adapter board. The driver is then simply snapped on to the adapter board from above. This is possible due to the robust standard interface in SKYPER modules which is suitable for use with plug-in connectors.

A few design tips on gate driver / IGBT connection for systems where wire connections are used are given below:

- Any parasitic inductances within the DC-link have to be minimized. Overvoltages may be absorbed by C- or RCD-snubbers between main terminals (plus and minus) of the power module.
- Make power patterns short and thick to reduce stray inductance and stray resistance.
- The connecting leads between gate driver and IGBT module must be kept as short as possible. Gate and emitter wiring must be twisted pair to minimize mutual induction, as magnetic field will be compensated for by equal current flow in opposite directions.
- The V_{CE} monitoring wiring must not be bundled together with the gate and emitter wiring.
- Gate wiring for top and bottom IGBT or other phases must not be bundled together.
- It is recommended that a 10k Ω resistor (R_{GE}) be placed between the gate and emitter. If wire connection is used, do not place the R_{GE} between printed circuit board and IGBT module. R_{GE} has to be placed very close to the IGBT module.
- Use auxiliary emitter contacts to minimize negative feedback effect on gate-emitter voltage.
- Use a suppressor diode (back-to-back Zener diode) between gate and emitter. The diode has to be placed very close to the IGBT module.
- The use of a capacitor (C_{GE}) between gate and emitter can be advantageous, even for high-power IGBT modules and parallel operation. The C_{GE} should be approximately 10% of the C_{GE} of the IGBT used. The C_{GE} has to be placed very close to the IGBT module.
- Current loops must be avoided.
- Place the gate resistances for turn-on and turn-off close together.
- Use an auxiliary printed circuit board with all of the components and solder to gate and emitter of the IGBT module, if the gate driver is used in higher-power applications.
- If external boost capacitors are used, the capacitors must be placed as close to the gate driver as possible in order to minimize parasitic inductance.

Gate Driver Connection & Stray Inductances

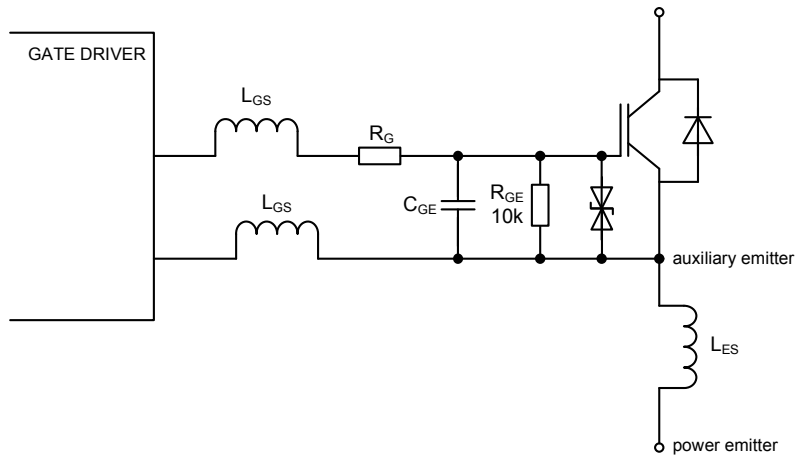

- If the ground of the driver is connected to the power emitter terminal, voltage is induced across L_{ES} due to the high di/dt of the load current. This voltage decreases the gate turn-on voltage and voltage is added to the gate turn-off voltage to slow down turn-on / turn-off. For this reason, stray inductances between auxiliary emitter and power emitter should not be shared.
- In order to ensure IGBT locking even when the driver supply voltage is turned off and voltage is being applied to the power circuit, a resistor (R_{GE}) has to be integrated.
- The suppressor diode must be placed very close to the IGBT module and can protect the IGBT gate in overvoltage conditions as well as limit the short circuit current should a short circuit occur. During short circuit, the gate emitter voltage may increase due to the miller capacitance between collector and gate. High dv/dt during short circuit causes a current to flow through the miller capacitor, in doing so increasing the gate emitter voltage. The suppressor diode will clamp this voltage. Furthermore, the suppressor diode can protect the gate driver from consequential damage should the IGBT module malfunction.
- The gate emitter capacitor C_{GE} is used as a smoothing capacitor, especially in the event of a short circuit, in order to reduce oscillation at the IGBT gate.

Please note:

It is recommended that the user's technical experts perform tests to ensure that no oscillations occur in the IGBT control paths.

Symbols and Terms used

Letter Symbol	Term
C_{GE}	Gate-emitter capacitor
L_{ES}	Emitter stray inductance
L_{GS}	Gate stray inductance
R_G	Gate resistor
R_{GE}	Gate-emitter resistor

References

- [1] <http://www.SEMIKRON.com>
- [2] Application Manual Power Modules, SEMIKRON International
- [3] M. Hermwille, "Plug and Play IGBT Driver Cores for Converters", Power Electronics Europe Issue 2, pp. 10-12, 2006
- [4] M. Hermwille, "IGBT Driver Calculation", Application Note AN-7004, SEMIKRON
- [5] M. Hermwille, "IGBT Gate Resistor – Principle and Application", Application Note AN-7003, SEMIKRON

DISCLAIMER

SEMIKRON reserves the right to make changes without further notice herein to improve reliability, function or design. Information furnished in this document is believed to be accurate and reliable. However, no representation or warranty is given and no liability is assumed with respect to the accuracy or use of such information. SEMIKRON does not assume any liability arising out of the application or use of any product or circuit described herein. Furthermore, this technical information may not be considered as an assurance of component characteristics. No warranty or guarantee expressed or implied is made regarding delivery, performance or suitability. This document supersedes and replaces all information previously supplied and may be superseded by updates without further notice.

SEMIKRON products are not authorized for use in life support appliances and systems without express written approval by SEMIKRON.

SEMIKRON INTERNATIONAL GmbH
 P.O. Box 820251 • 90253 Nürnberg • Deutschland • Tel: +49 911-65 59-234 • Fax: +49 911-65 59-262
sales.skd@semikron.com • www.semikron.com

11283520 02/2008