

Centro Federal de Educação Tecnológica de Santa Catarina
Departamento de Eletrônica
Eletrônica Básica

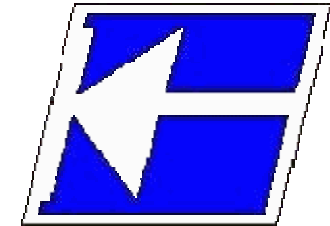

Semicondutores

e

Diodos

Prof. Clóvis Antônio Petry.

Florianópolis, agosto de 2007.

Nesta aula

Seqüência de conteúdos:

1. Semicondutores;
2. Junções PN;
3. Diodos;
4. Matrizes de contato;
5. Fontes de tensão.

Bibliografia

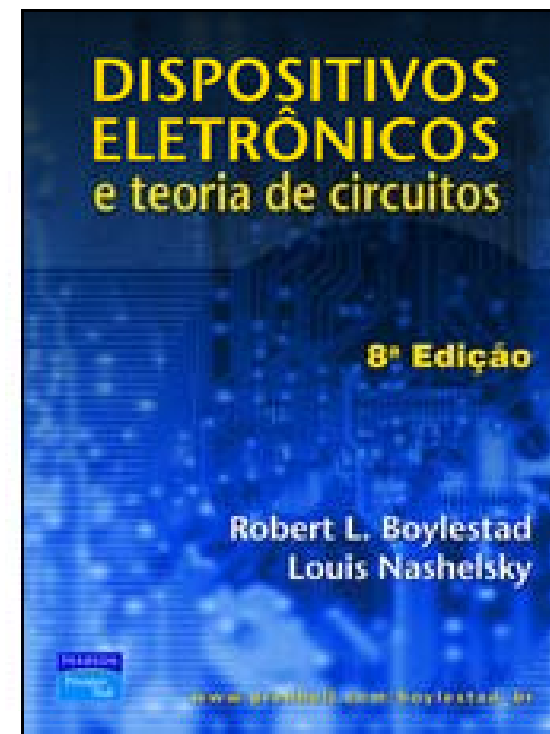
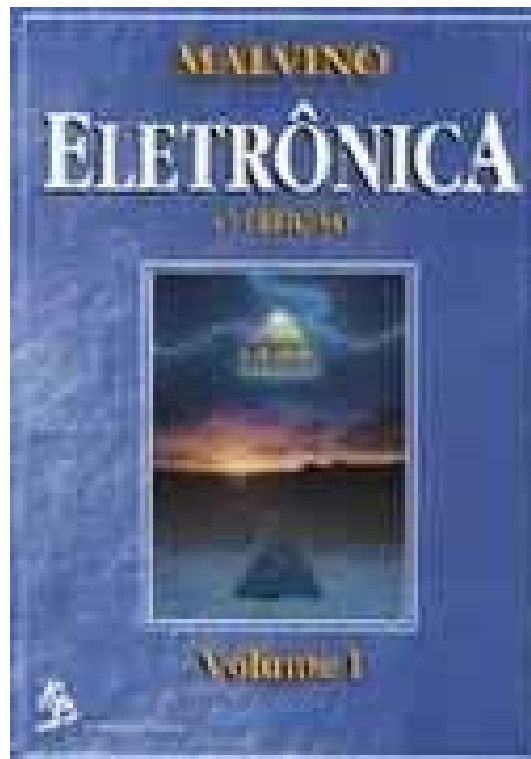

Materiais semicondutores

$$R = \frac{\rho \cdot l}{A}$$

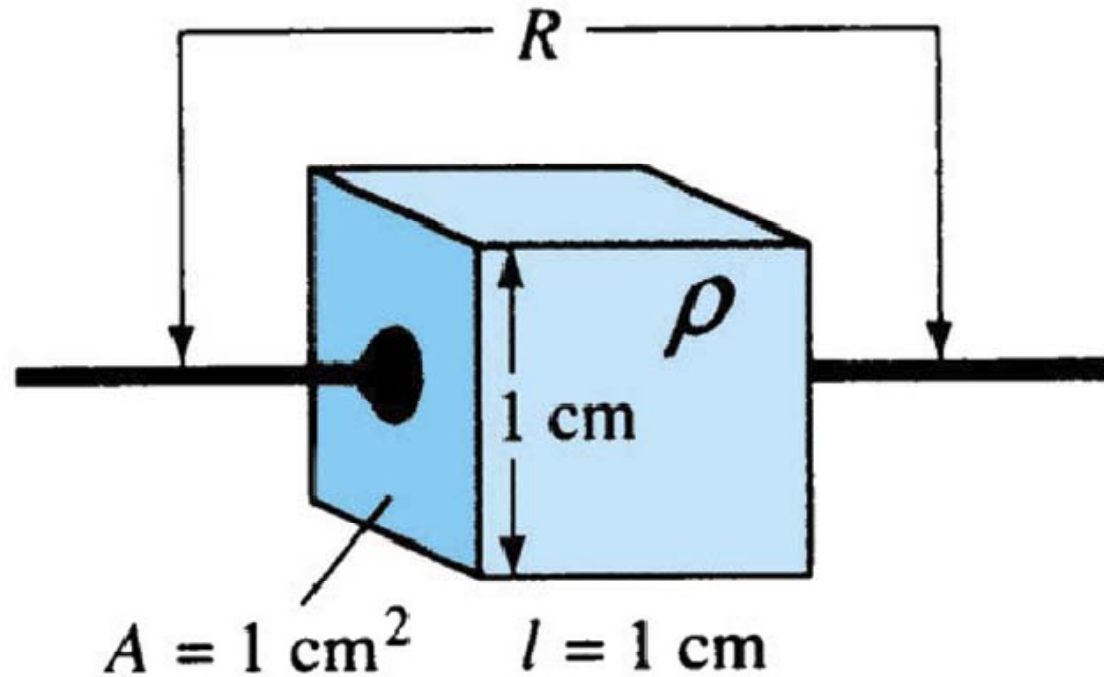

Condutor

$$\rho \cong 10^{-6} \Omega cm$$

(cobre)

Semicondutor

$$\rho \cong 50 \Omega cm \text{ (germânio)}$$

$$\rho \cong 50 \cdot 10^3 \Omega cm \text{ (silício)}$$

Isolante

$$\rho \cong 10^{12} \Omega cm$$

(mica)

Materials semicondutores

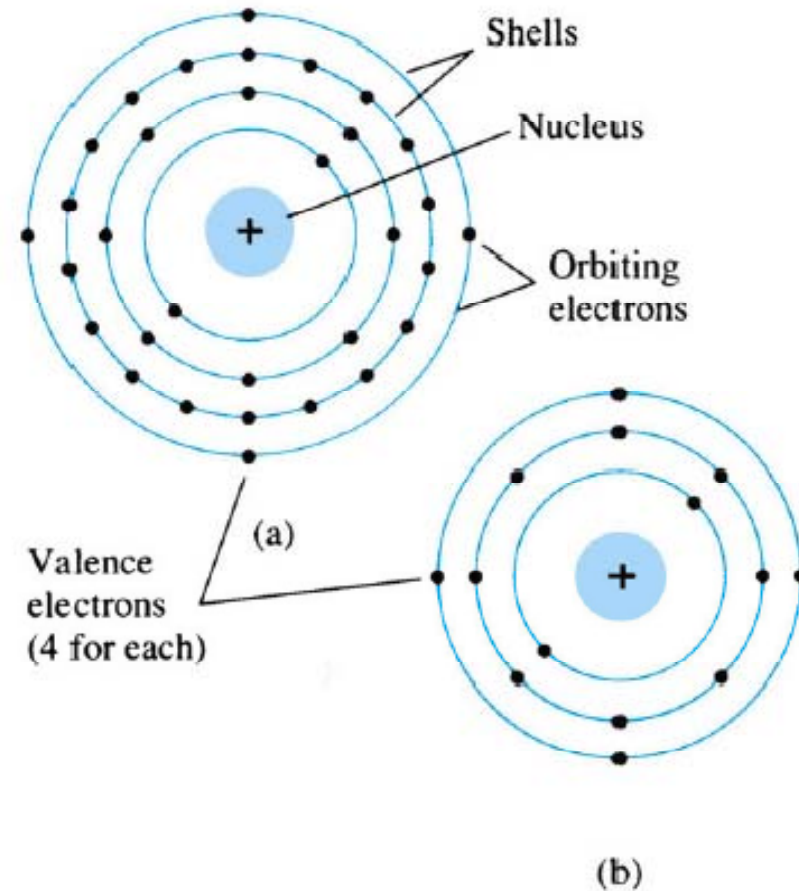
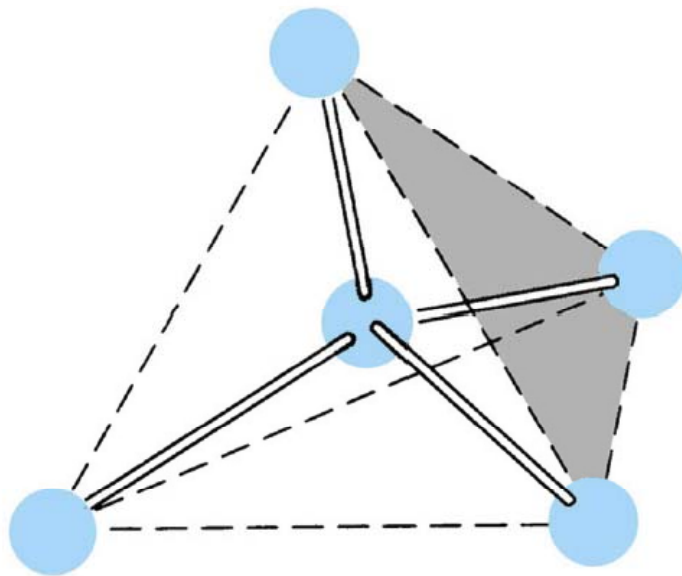

Atomic structure: (a) germanium; (b) silicon.

Materiais semicondutores

Níveis de energia:

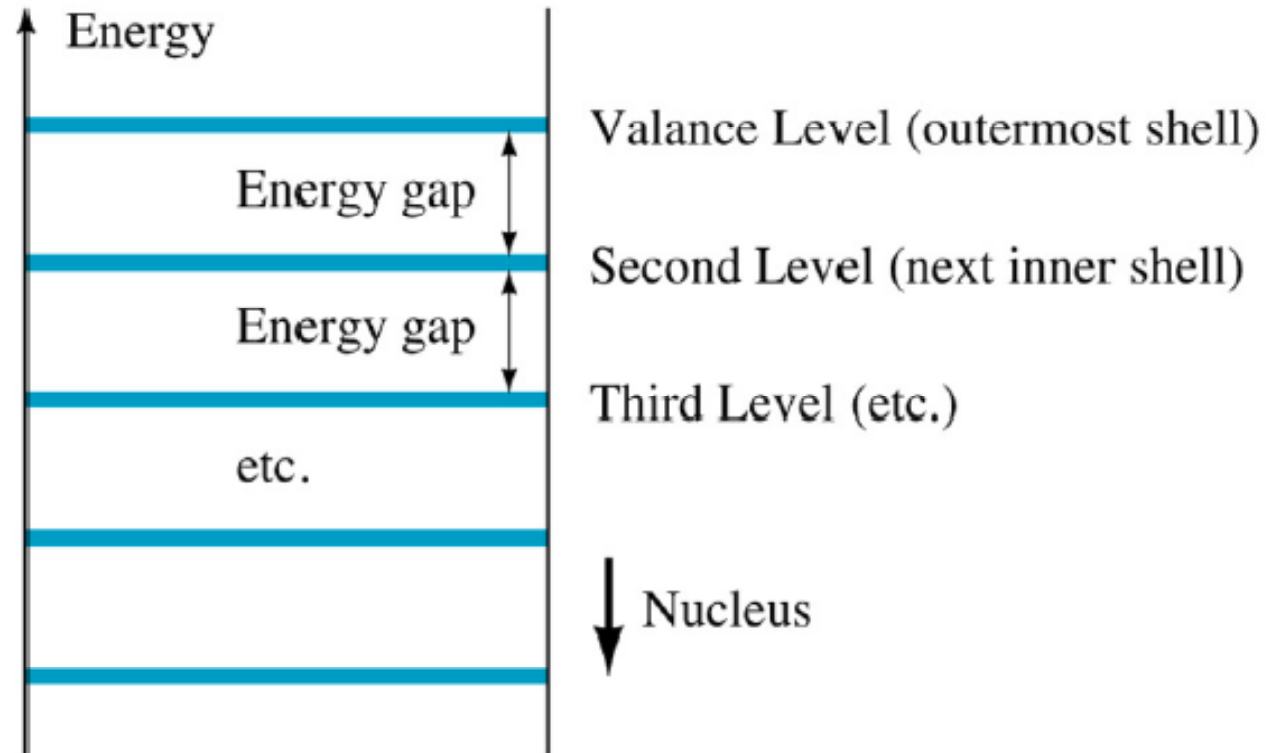

Condutor: $\rho = 10^{-6} \Omega\text{cm}$ [cobre]

Semicondutor: $\rho = 50 \Omega\text{cm}$ [germânio]

Semicondutor: $\rho = 50 \text{ k}\Omega\text{cm}$ [silício]

Isolante: $\rho = 10^{12} \Omega\text{cm}$ [mica]

Materiais semicondutores

Níveis de energia:

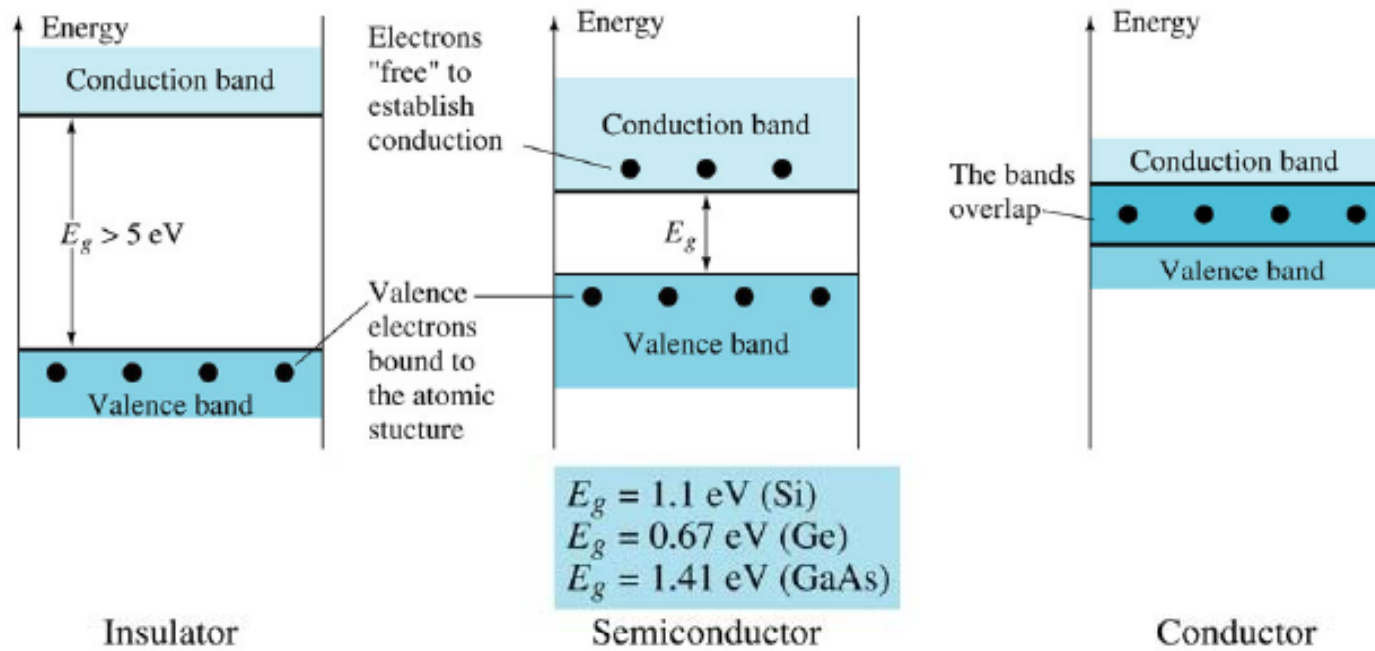

Materiais semicondutores

Materiais intrínsecos e extrínsecos do tipo N e P:

- Materiais intrínsecos são semicondutores cuidadosamente refinados para se obter a redução de impurezas a um nível muito baixo – são basicamente tão puros quanto permite a tecnologia moderna;
- Um material semicondutor submetido ao processo de dopagem é chamado de material extrínseco.

Materials semicondutores

Materials extrínsecos do tipo N:

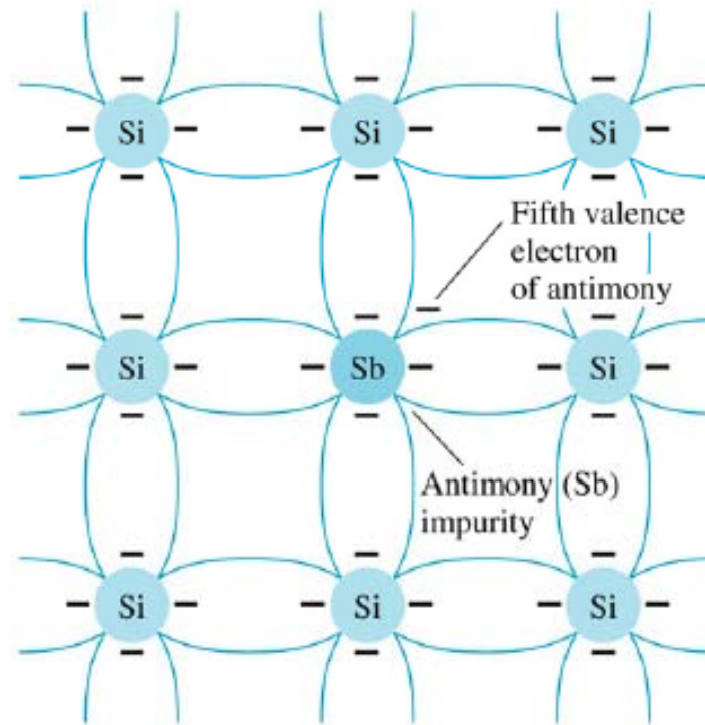

Antimony impurity in n-type material.

Materials semicondutores

Materials extrínsecos do tipo N:

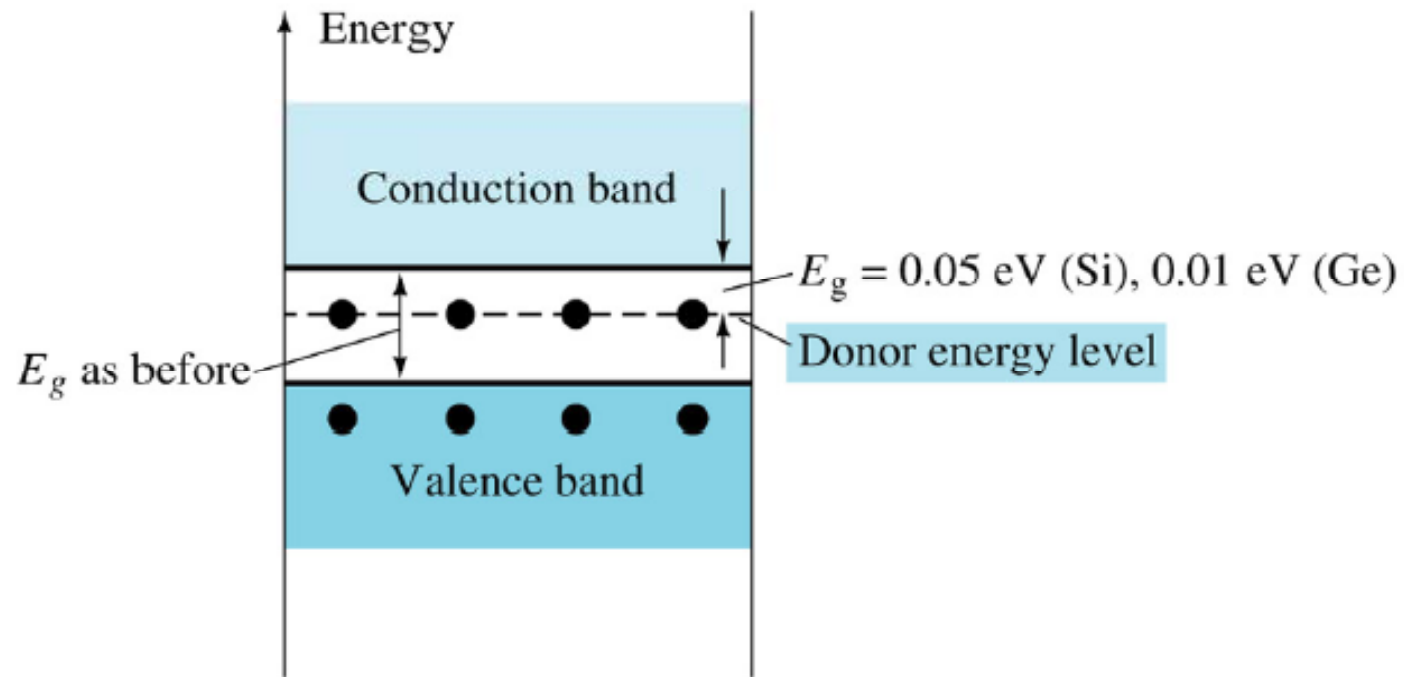

Effect of donor impurities on the energy band structure.

Materials semicondutores

Materials extrínsecos do tipo P:

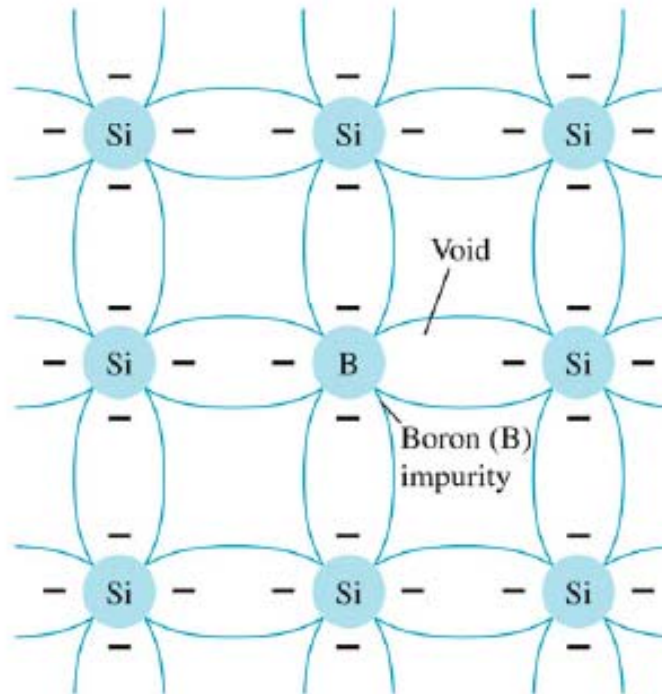

Boron impurity in *p*-type material.

Materials semicondutores

Materials extrínsecos do tipo P:

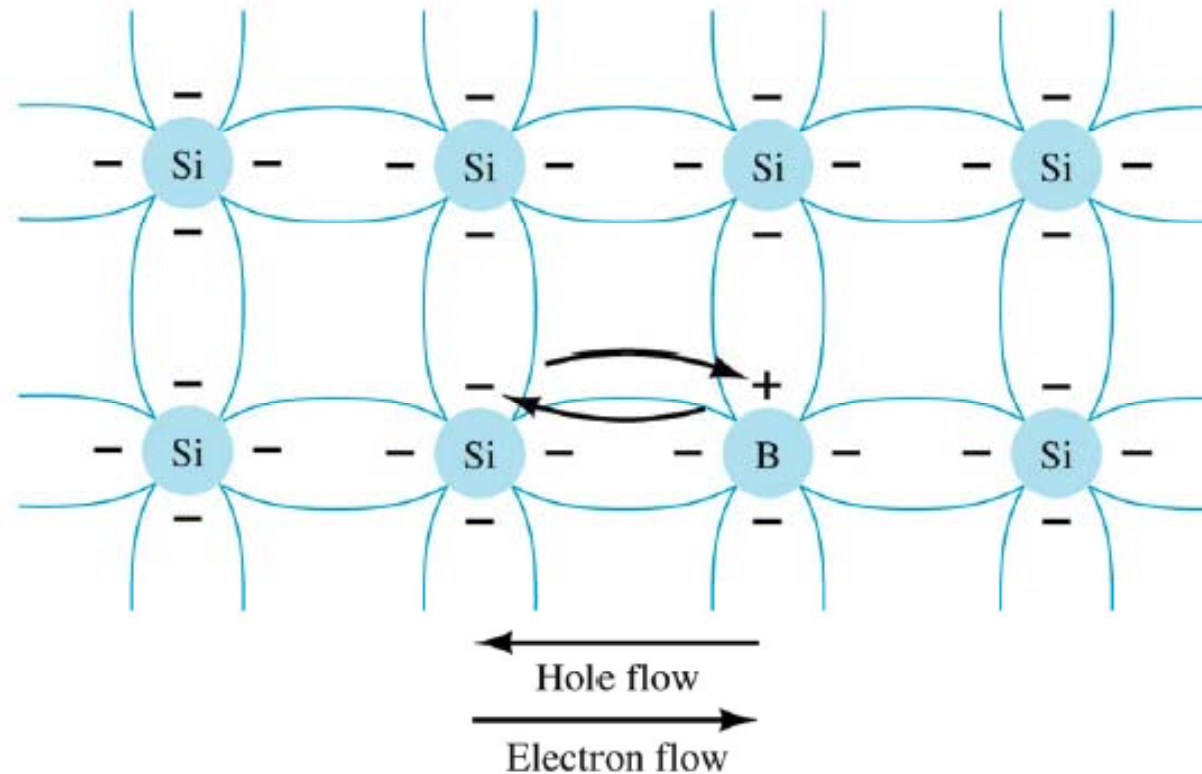

Electron versus hole flow.

Materiais semicondutores

Portadores de carga nos materiais P e N:

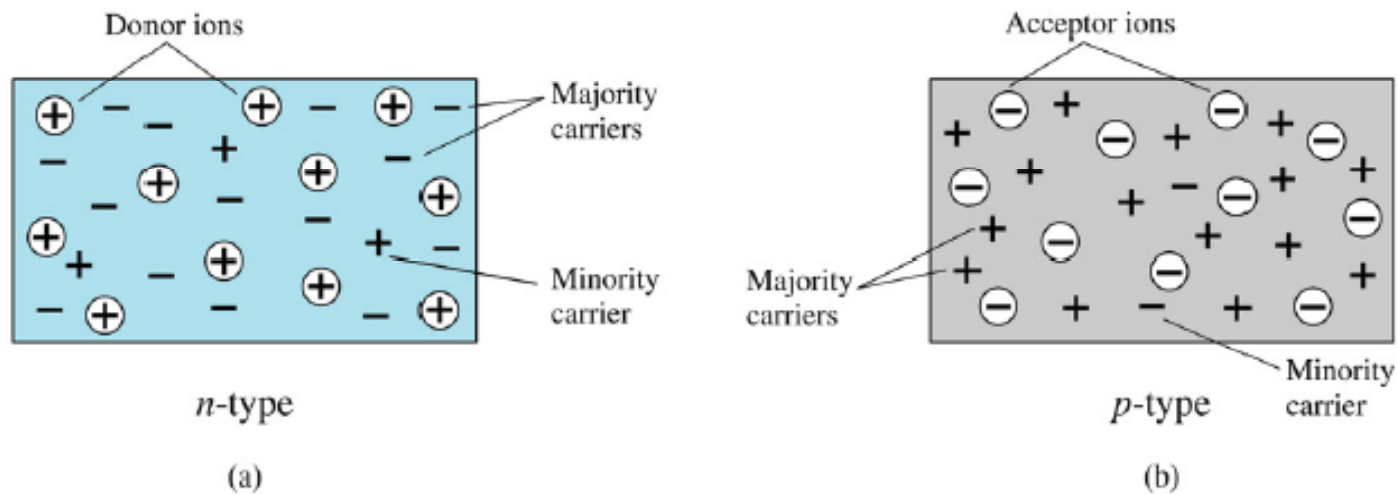

(a) *n*-type material; (b) *p*-type material.

Junções P e N

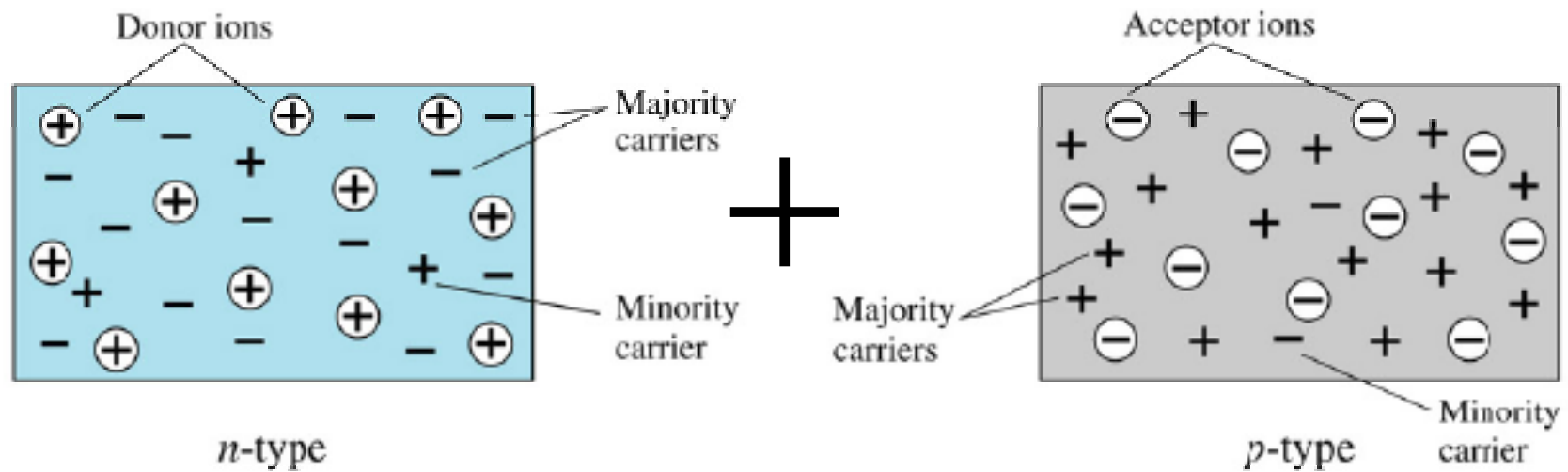

Junções P e N

Diodo semicondutor, uma introdução:

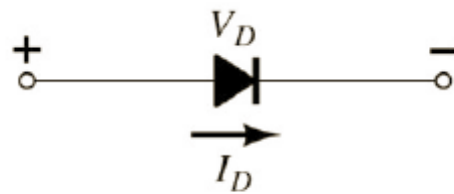

(a)

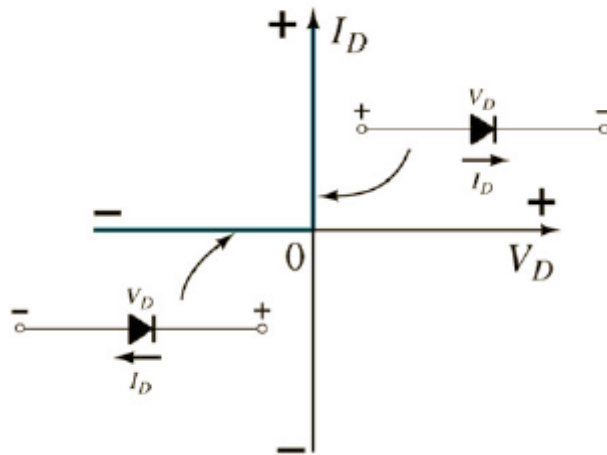

(b)

Ideal diode: (a) symbol; (b) characteristics.

Junções P e N

Diodo semicondutor, uma introdução:

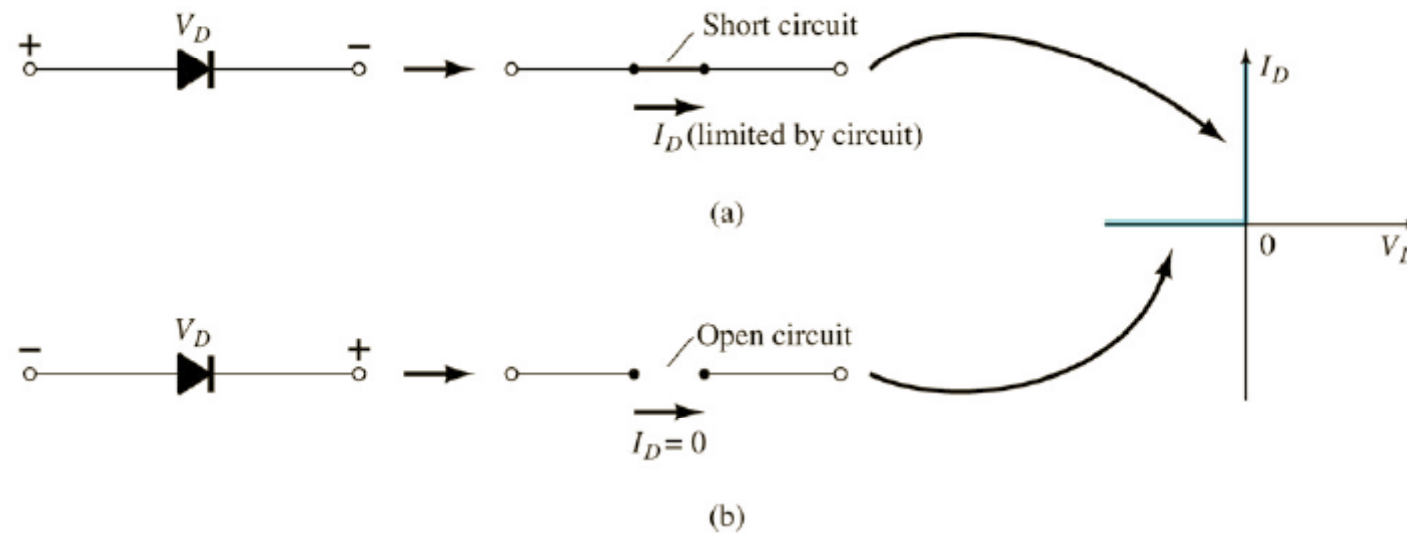

(a) Conduction and (b) nonconduction states of the ideal diode as determined by the applied bias.

Junções P e N

Diodo semiconductor, uma introdução:

Em condução:

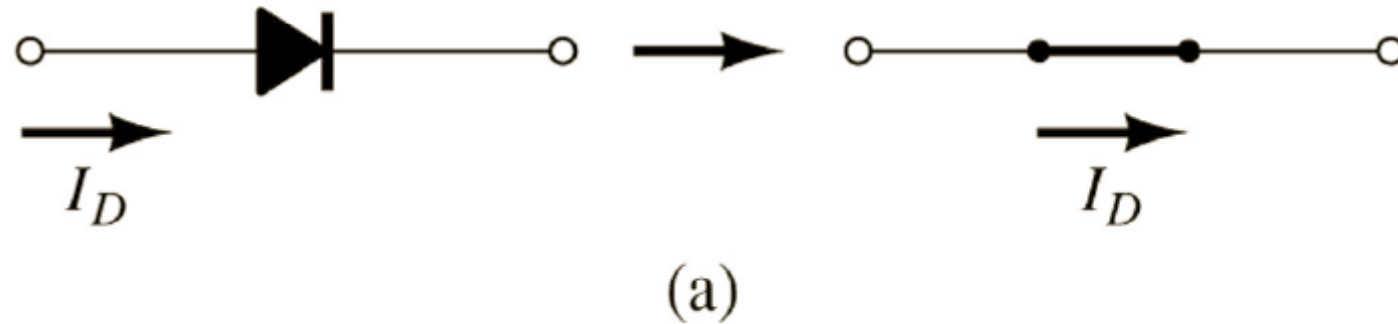

Não condução:

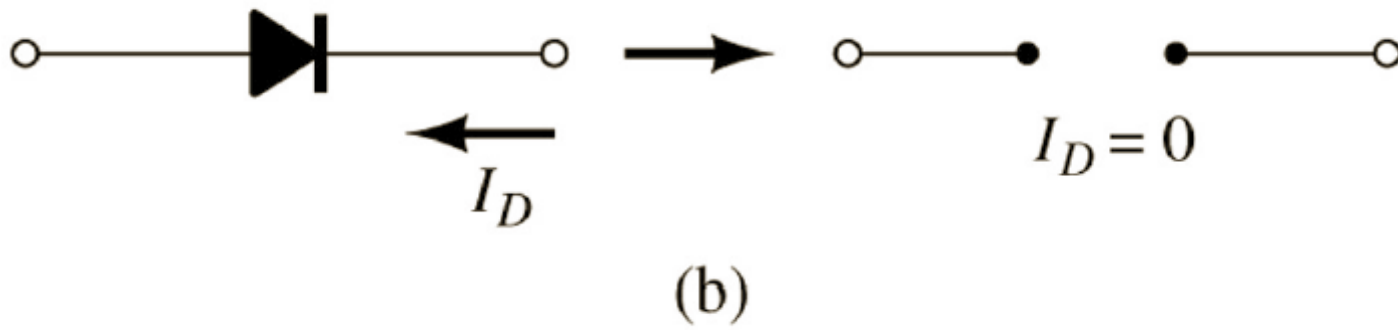

Junção PN – Sem polarização

$$V_D = 0V$$

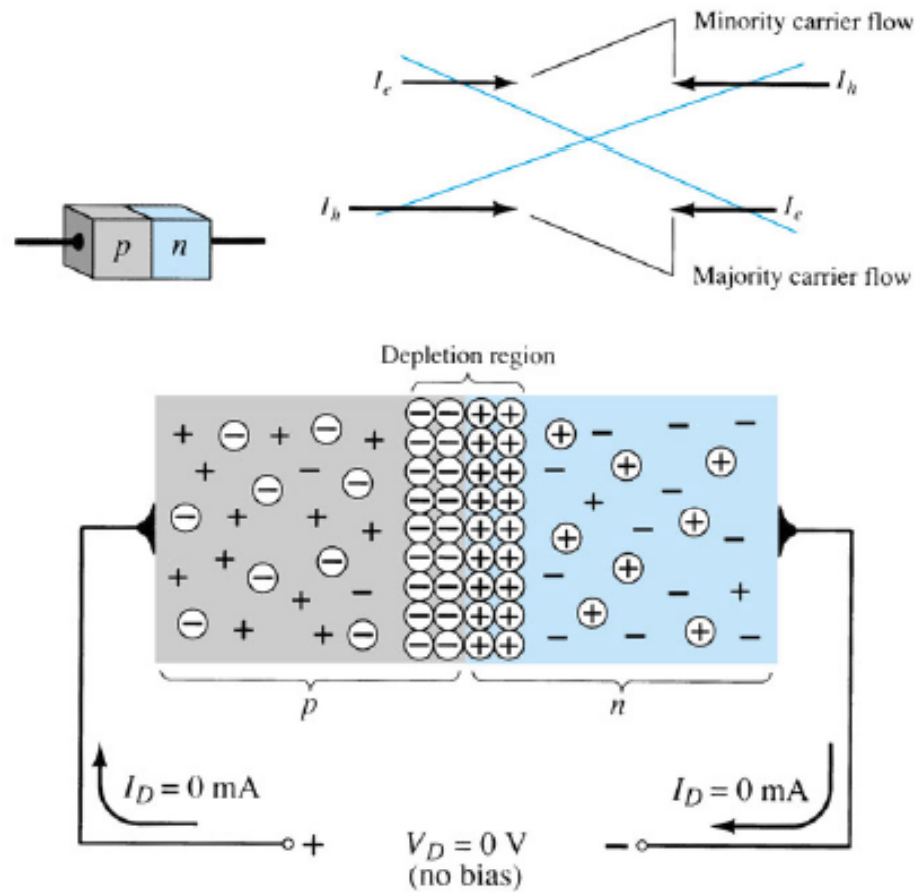

Junção PN – Sem polarização

$$V_D = 0V$$

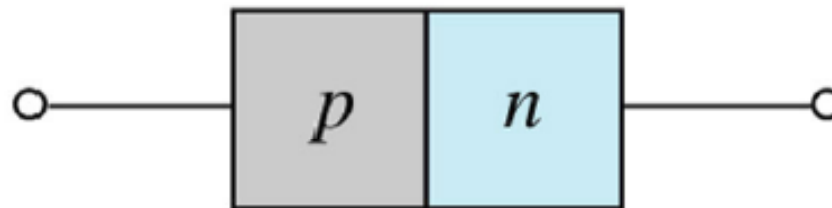
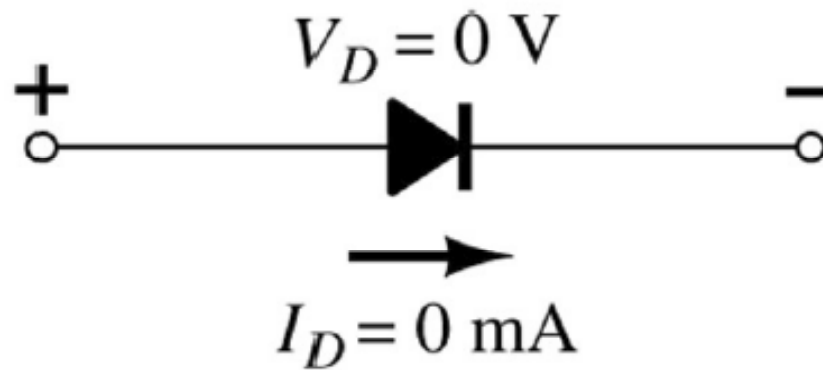
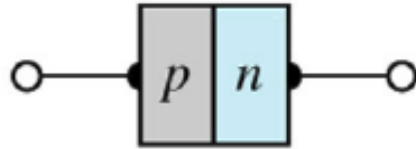

Junção PN – Reversamente polarizada

$$V_D < 0V$$

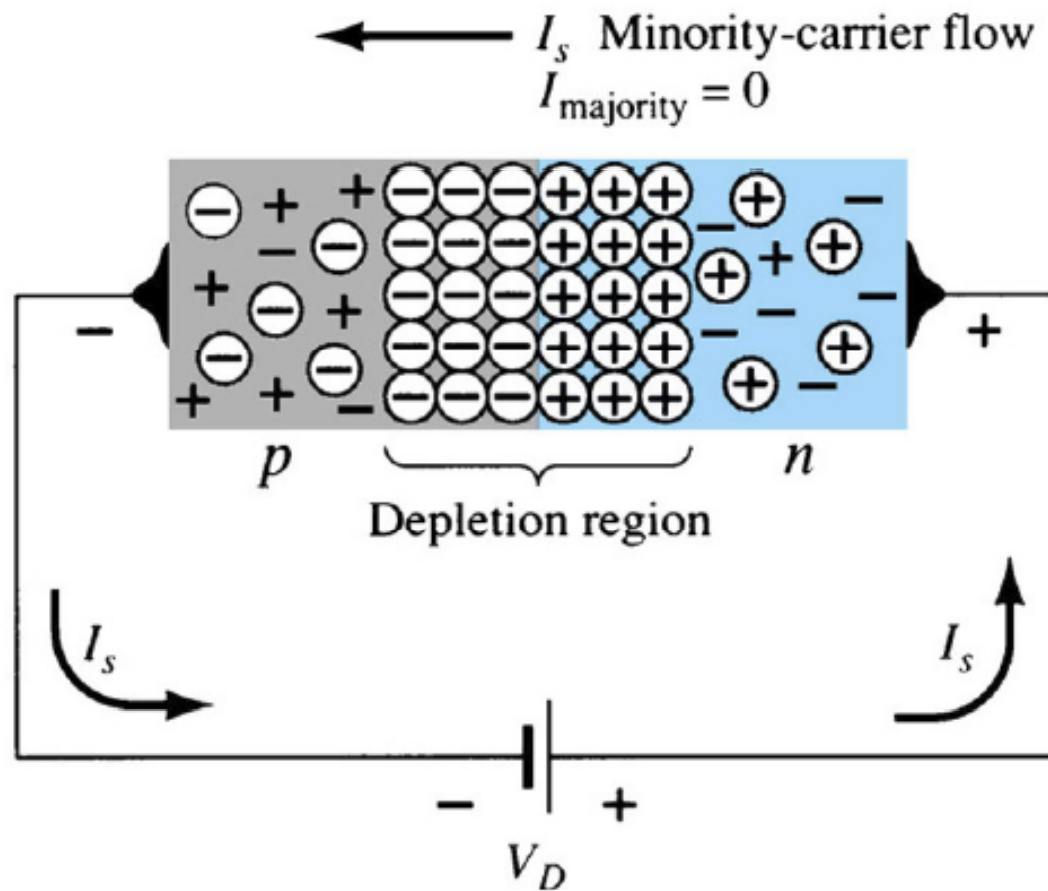

Junção PN – Reversamente polarizada

$$V_D < 0V$$

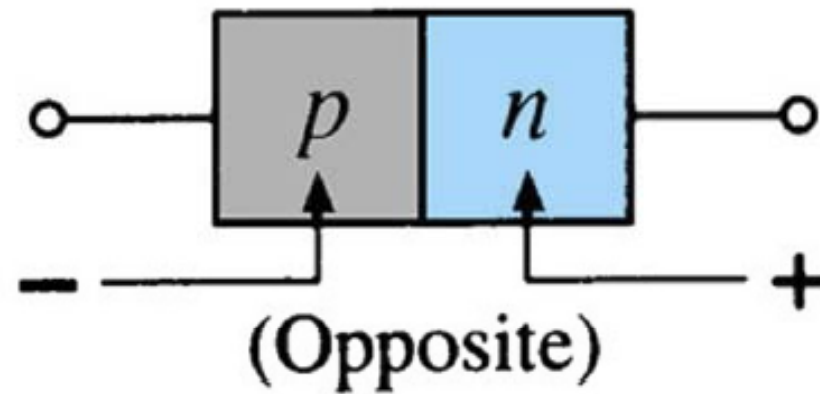
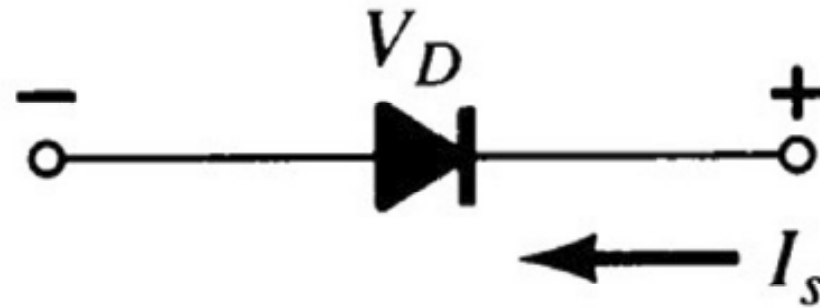

Junção PN – Diretamente polarizada

$$V_D > 0V$$

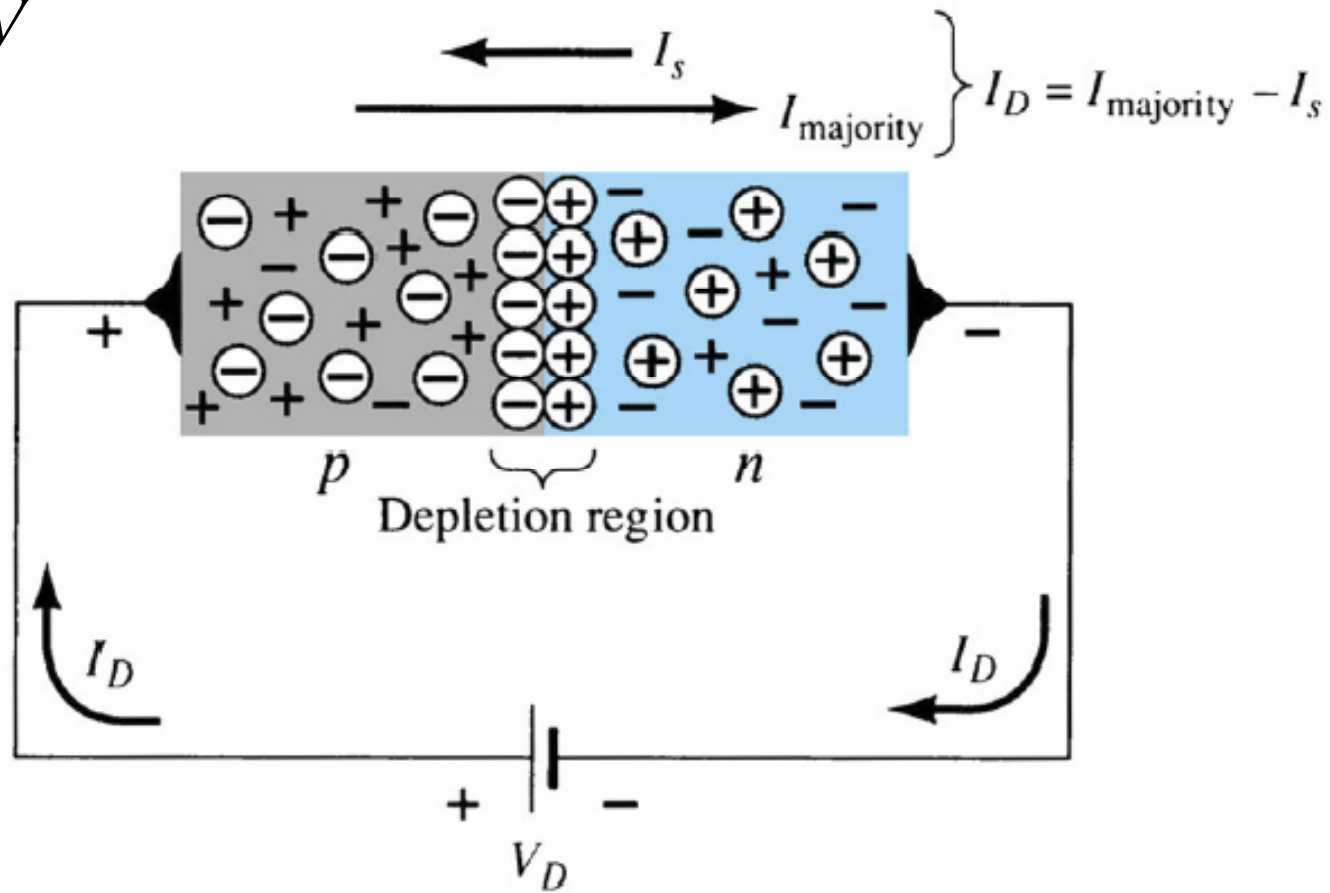

Junção PN – Efeito da temperatura

A corrente de saturação reversa I_S terá sua amplitude praticamente dobrada para aumento de $10\text{ }^\circ\text{C}$ na temperatura.

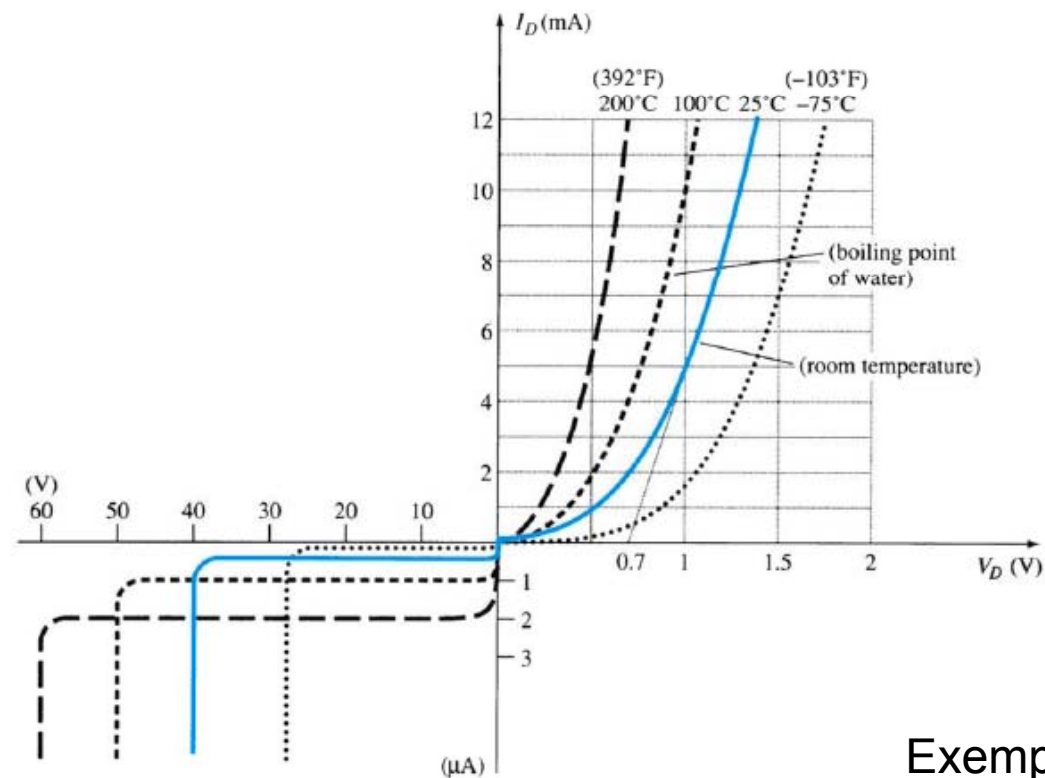

Exemplo 2.6 do Malvino.

Junção PN – Silício versus Germânio

- Tensão reversa:
 - Silício: 1000 V;
 - Germânio: 400 V.
- Temperatura de operação:
 - Silício: 200 °C;
 - Germânio: 100 °C.
- Queda de tensão direta:
 - Silício: 0,7 V;
 - Germânio: 0,3 V.

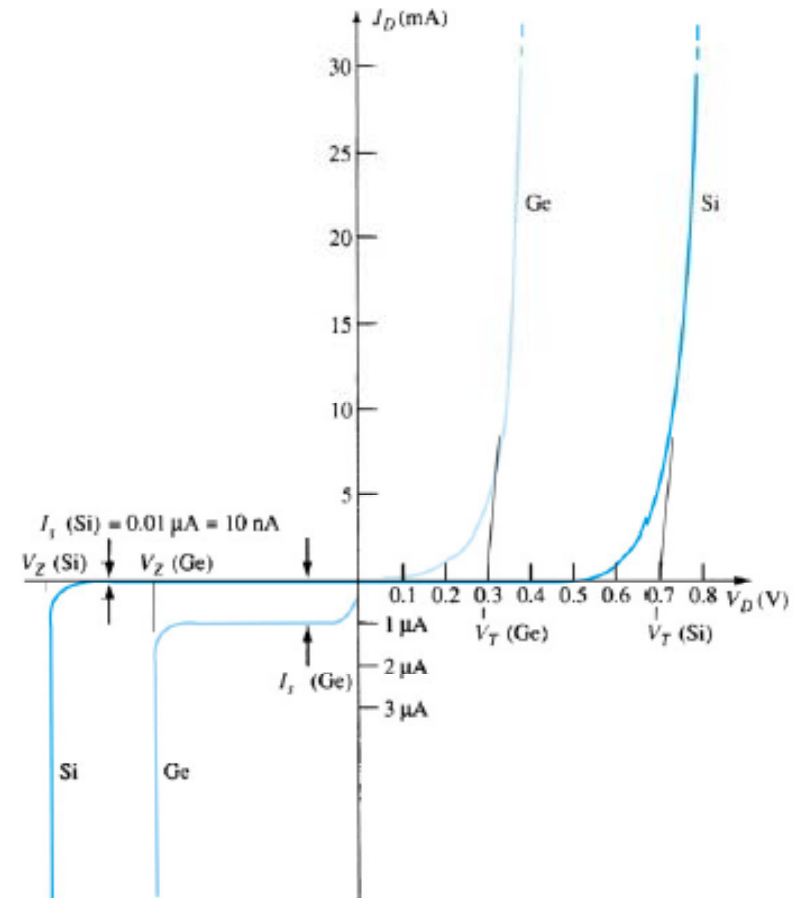

Exercícios

Malvino:

- Lista do capítulo 2.

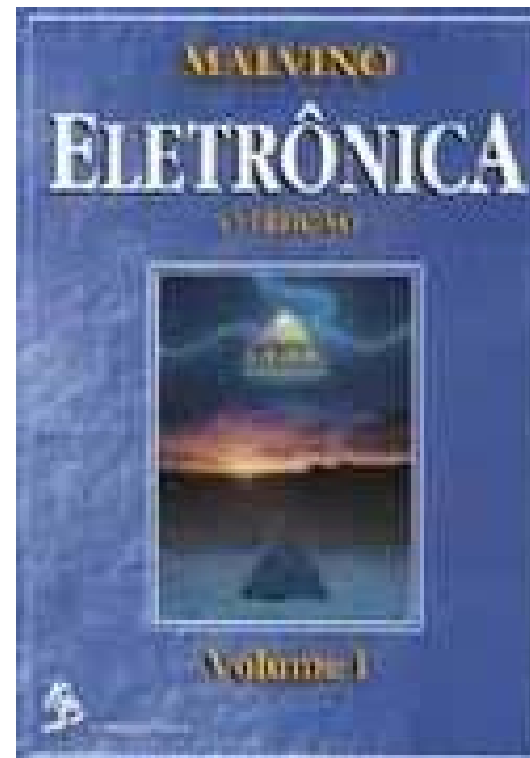
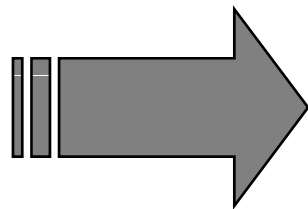

Diodo – Curva $I_D \times V_D$

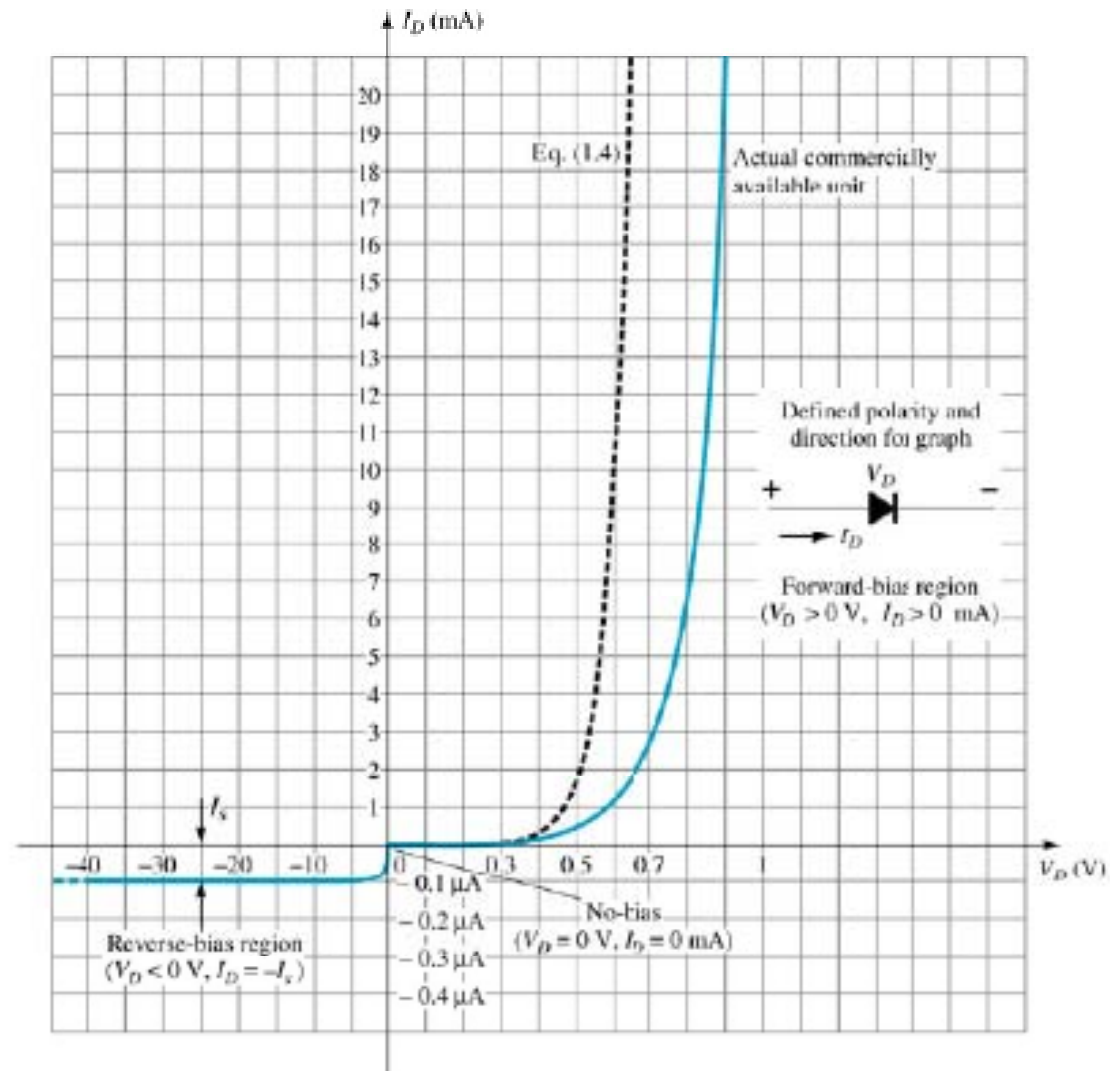

Diodo – Curva I_D x V_D

$$I_D = I_S \left(e^{\frac{K \cdot V_D}{T_K}} - 1 \right)$$

- I_D = corrente direta;
- V_D = tensão de polarização;
- I_S = corrente de saturação reversa;
- $K = 11.600/n$ com $n = 1$ para o Ge e $n = 2$ para o Si;
- $T_K = T_C + 273^\circ$.

Diodo – Região zener

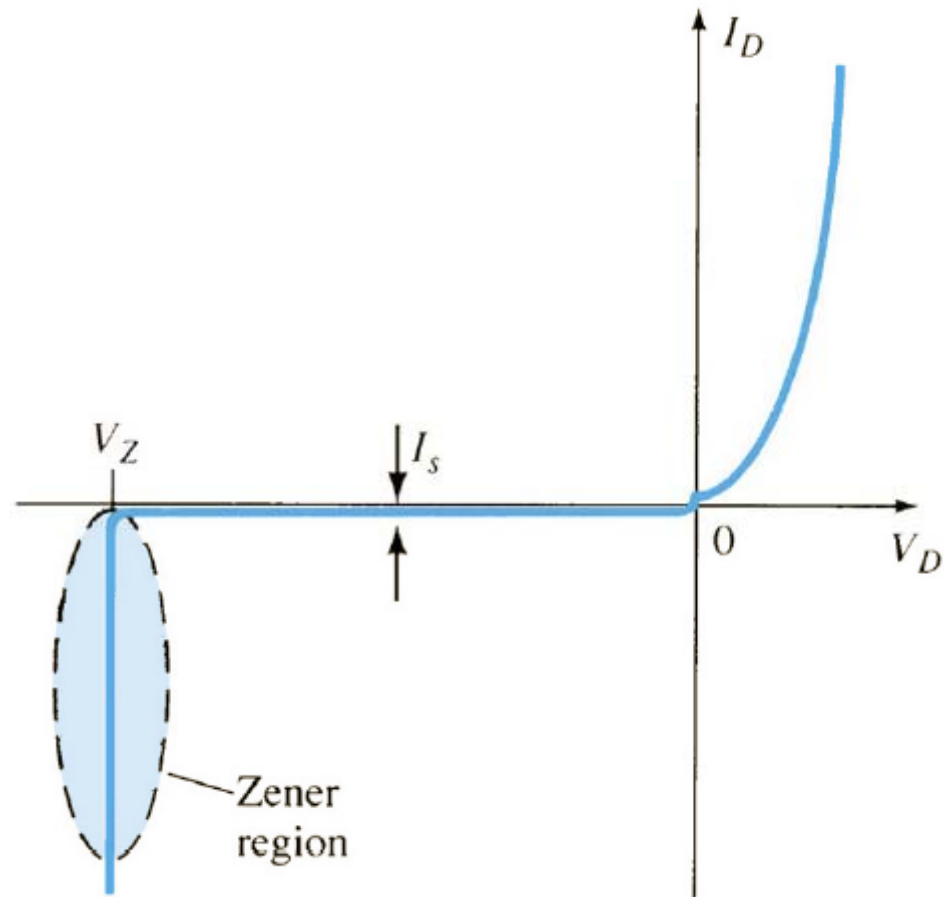

Resistências do diodo

Resistência CC ou estática:

$$R_D = \frac{V_D}{I_D}$$

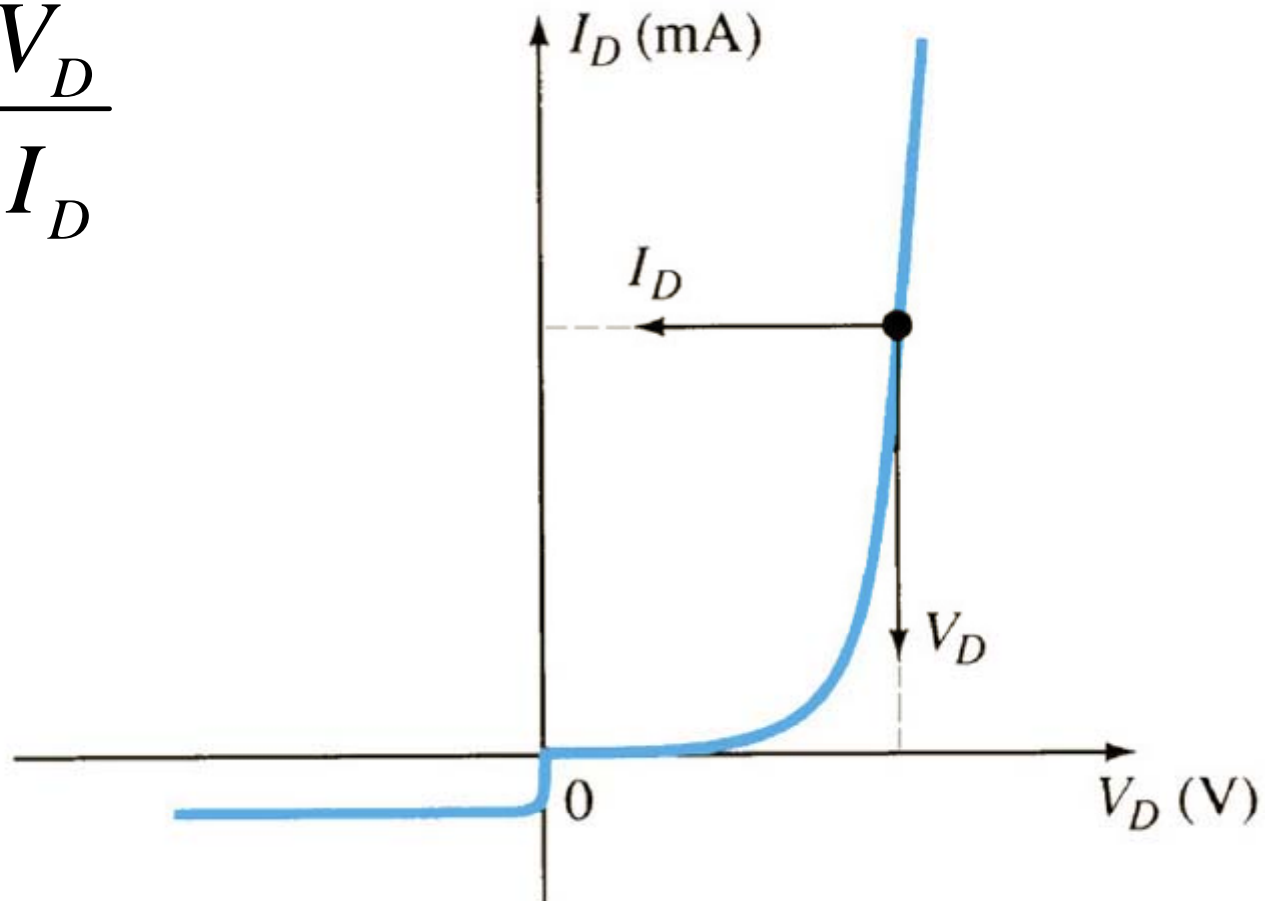

Resistências do diodo

Resistência CA ou dinâmica:

$$r_D = \frac{\Delta V_D}{\Delta I_D}$$

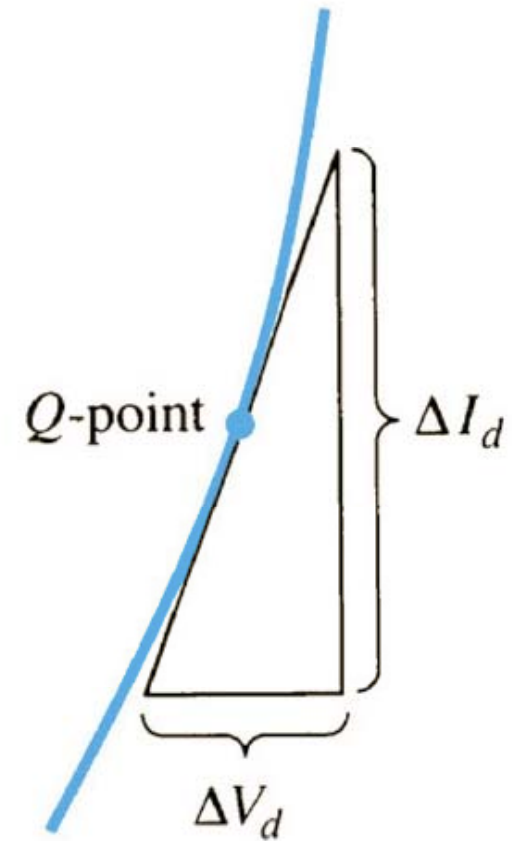
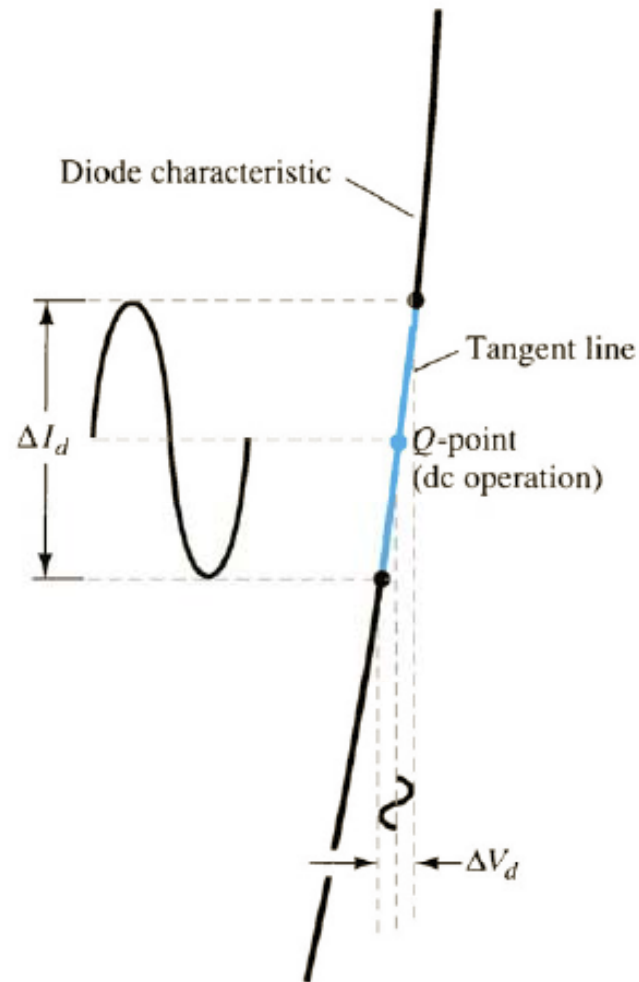

Resistências do diodo

Resistência CA média ou resistência de corpo:

$$r_{av} = \frac{\Delta V_d}{\Delta I_d}$$

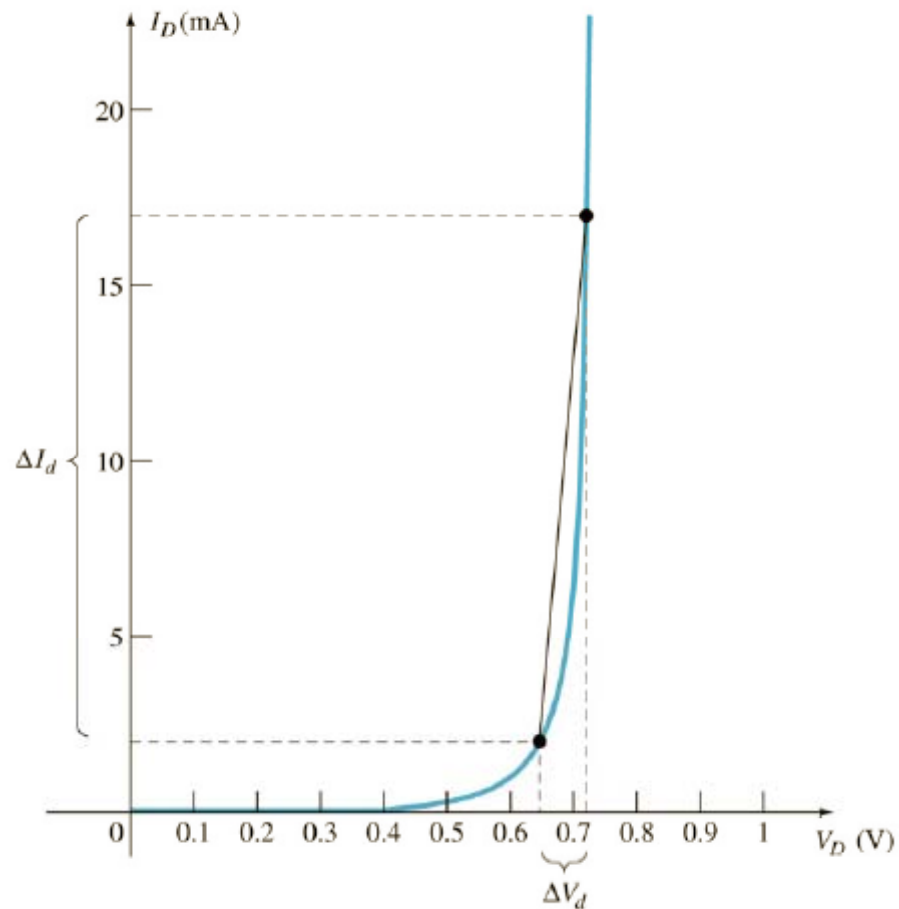

Modelo ideal do diodo

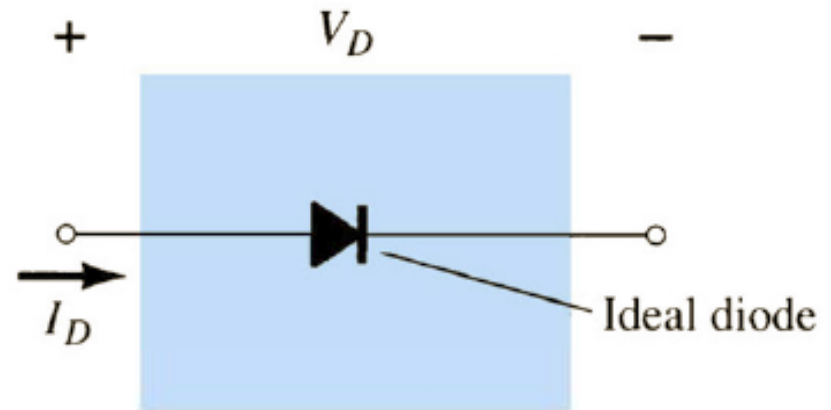
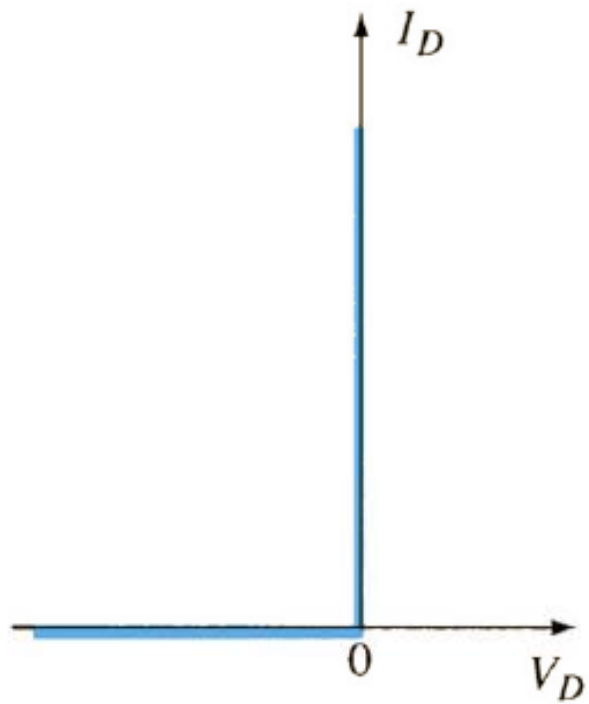

Exemplo 3.4 do Malvino.

Modelo simplificado do diodo

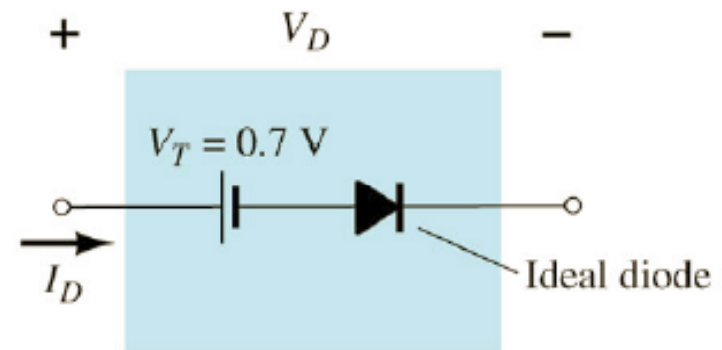
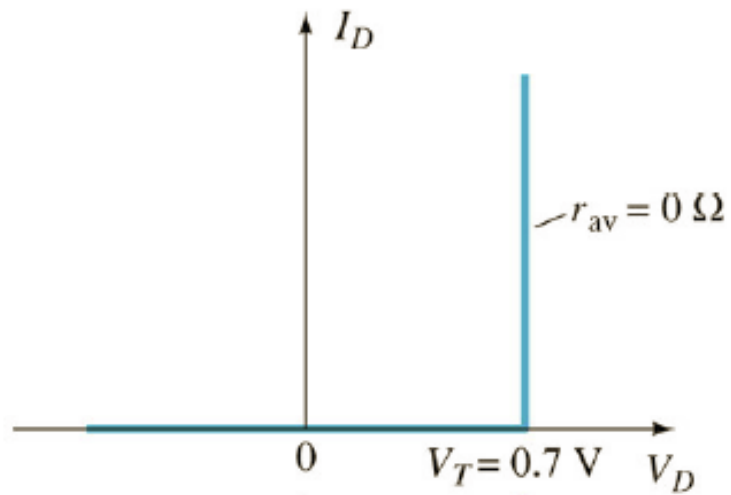

Exemplo 3.5 do Malvino.

Modelo linear por partes do diodo

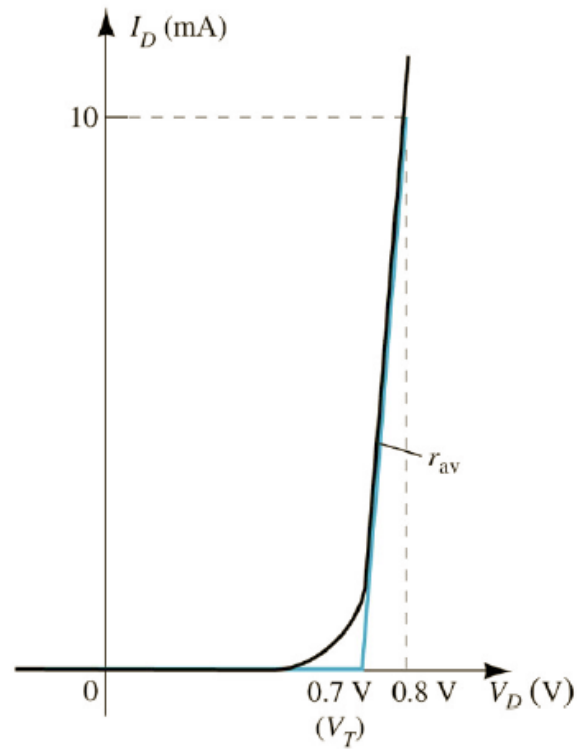
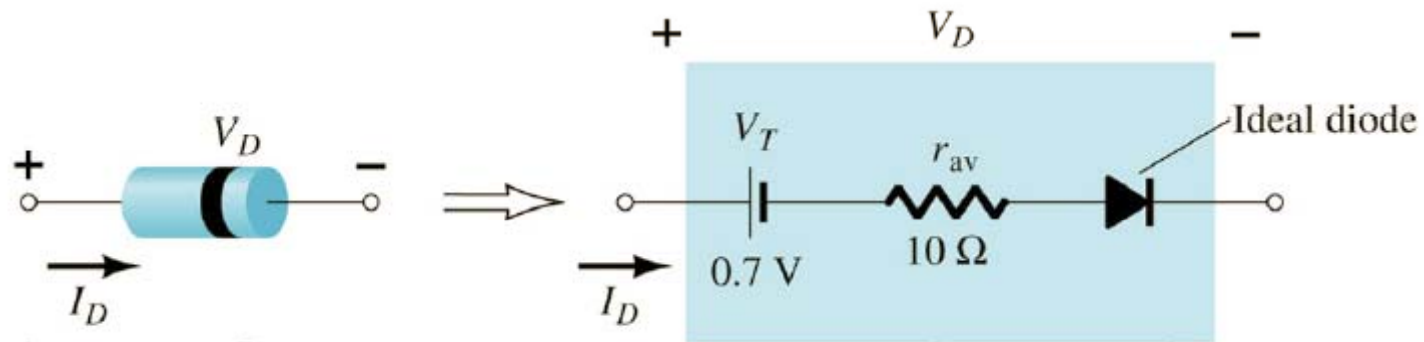

Exemplo 3.6 do Malvino.

Exercícios

Malvino:

- Lista do capítulo 3.

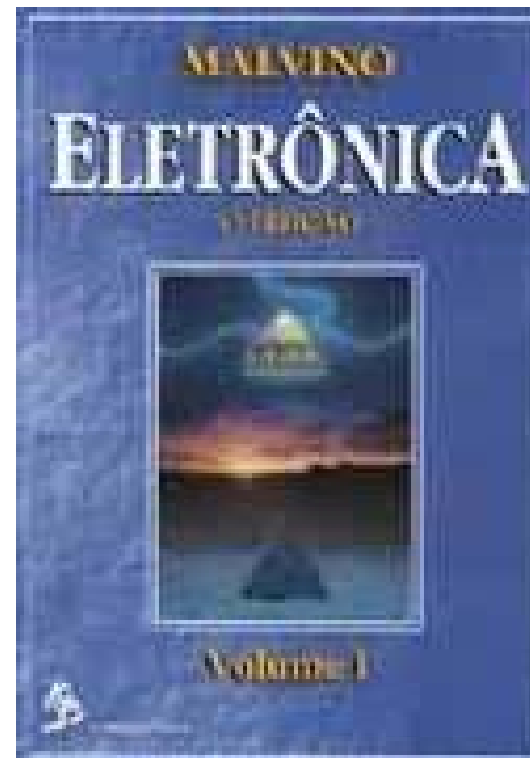
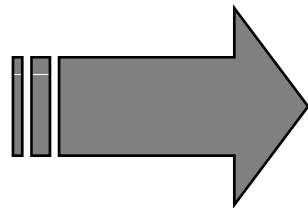

Matriz de contatos

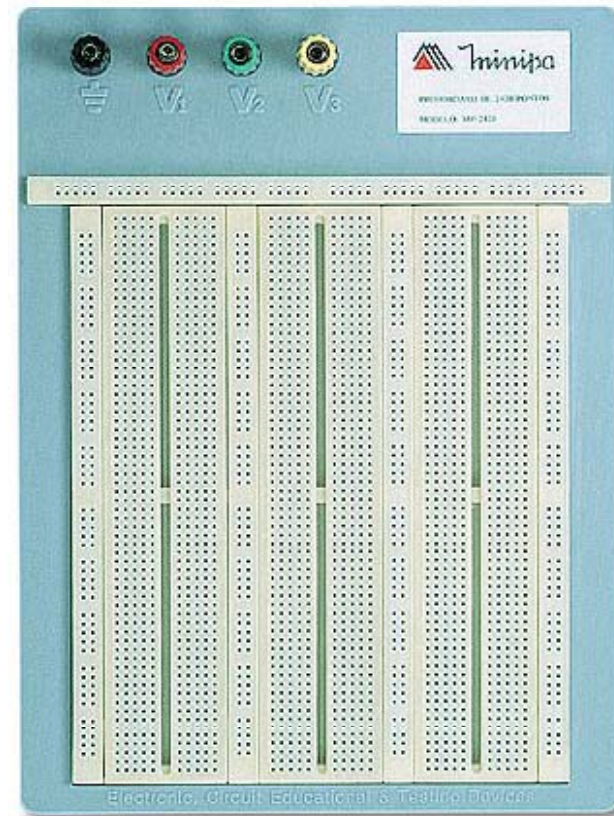
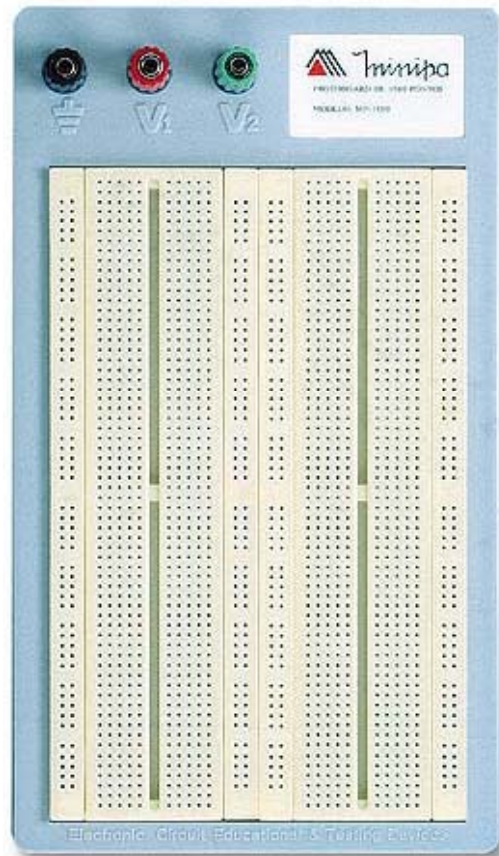

Matriz de contatos = pront-o-labor = protoboard

Matriz de contatos

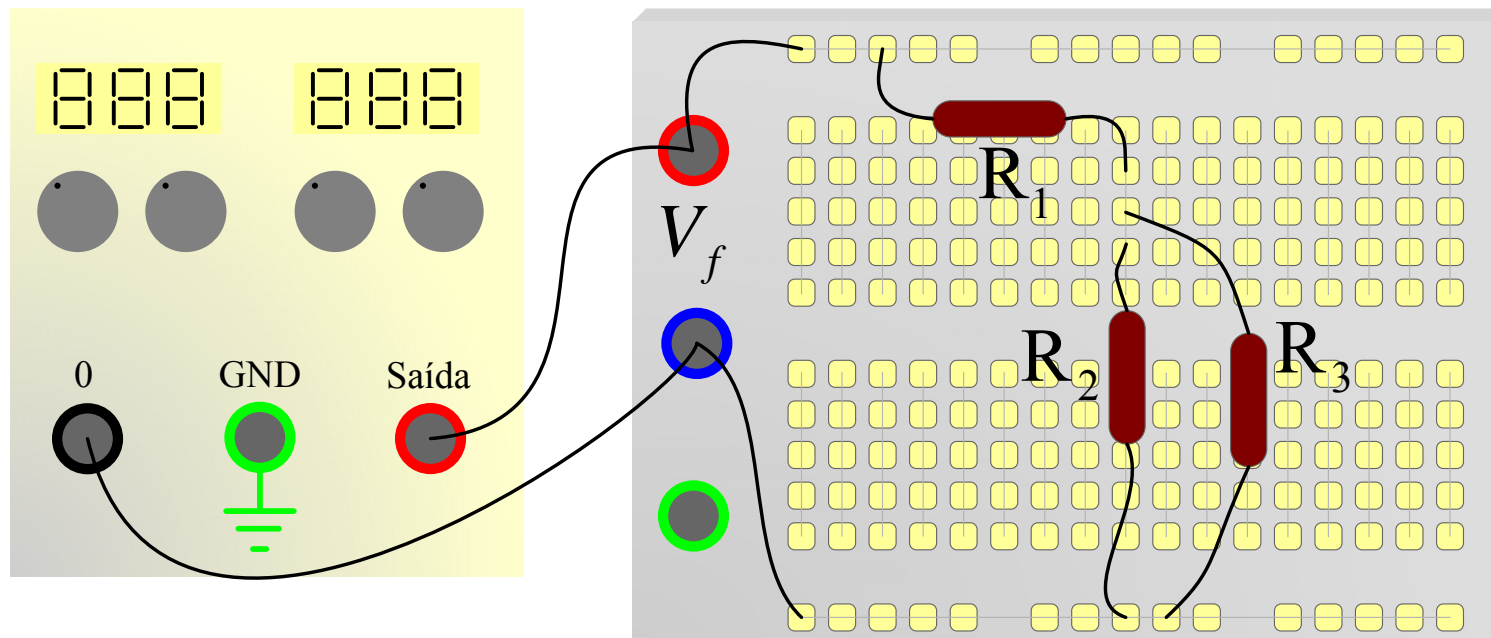
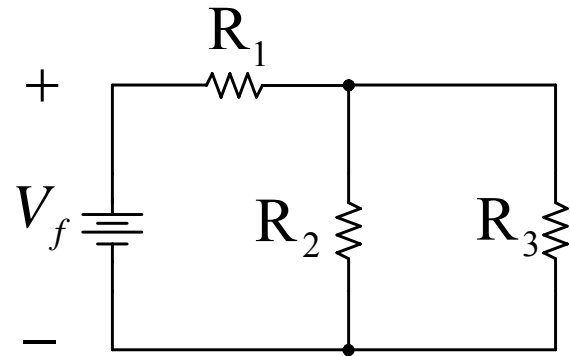

Matriz de contatos

Exercícios:



Eletrônica Básica (1880132A)

Tarefa 01: A seguir, para cada circuito elétrico abaixo, desenha na matriz de contatos os resistores e as conexões entre os mesmos e destas até a(s) fonte(s), conforme o exemplo das figuras 1 e 2.



Figura 1 – Circuito elétrico (a).



Figura 2 – Desenho da montagem do circuito elétrico (a).

Fontes de tensão

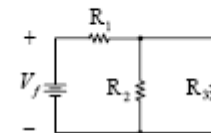

Na próxima aula

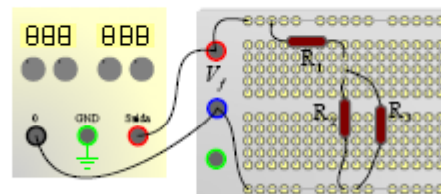
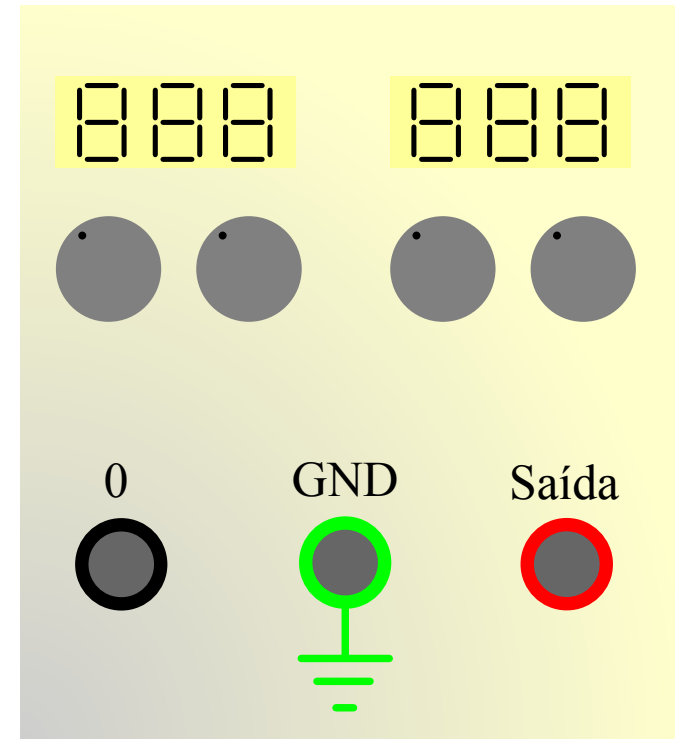
Seqüência de conteúdos:

1. Características dos diodos;
2. Análise de circuitos com diodos;
3. Aplicações simples.