

**Centro Federal de Educação Tecnológica de Santa Catarina**  
**Departamento Acadêmico de Eletrônica**  
**Retificadores**



**Resposta Transitória,  
Associação de Indutores  
e Aplicações**

**Prof. Clóvis Antônio Petry.**

**Florianópolis, abril de 2008.**

# Bibliografia para esta aula

## Capítulo 12: Indutores

1. Resposta transitória;
2. Associação de indutores;
3. Aplicações.

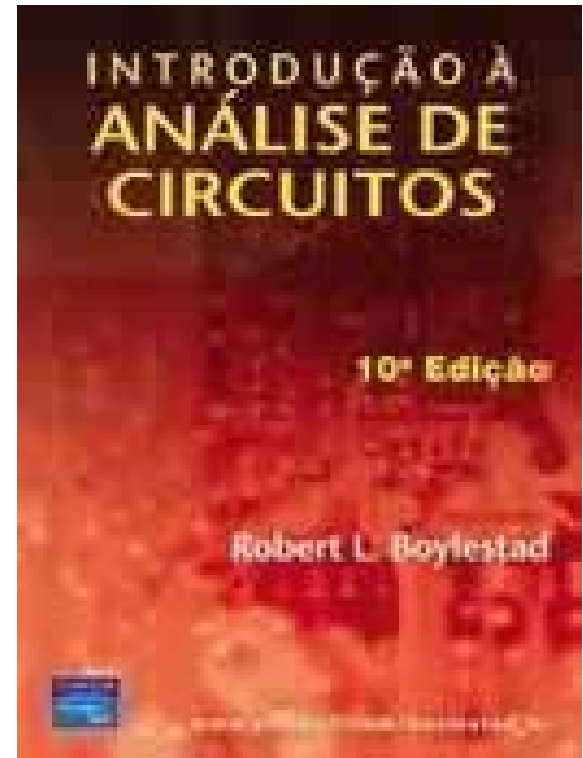

# Transientes em circuitos R-L - Armazenamento

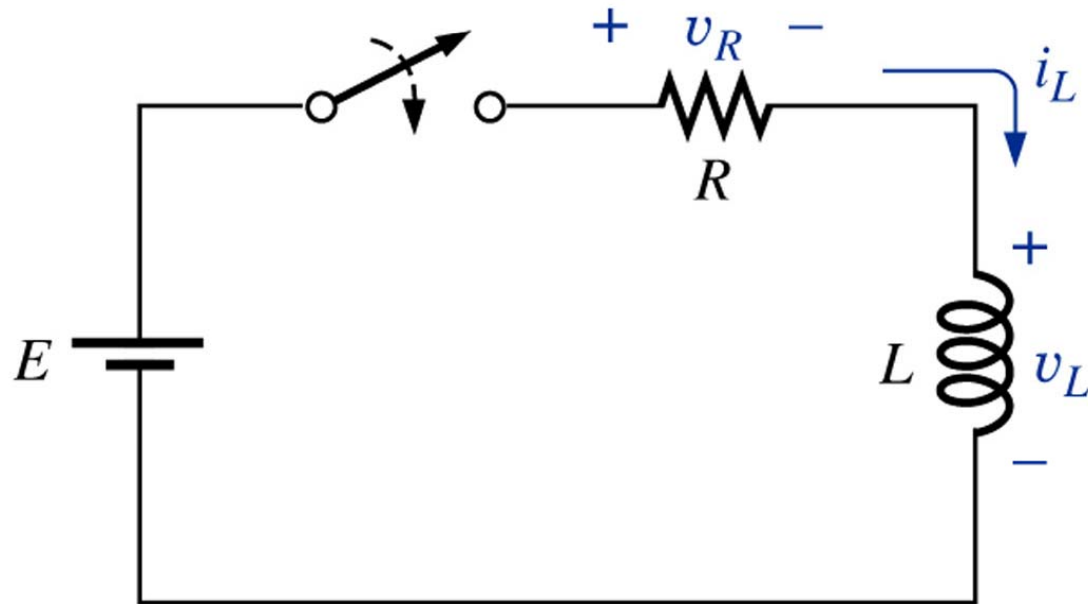

Um indutor ideal ( $R=0$ ) se comporta como um curto-circuito em um circuito de corrente contínua, uma vez estabelecido o estado estacionário.

# Transientes em circuitos R-L - Armazenamento

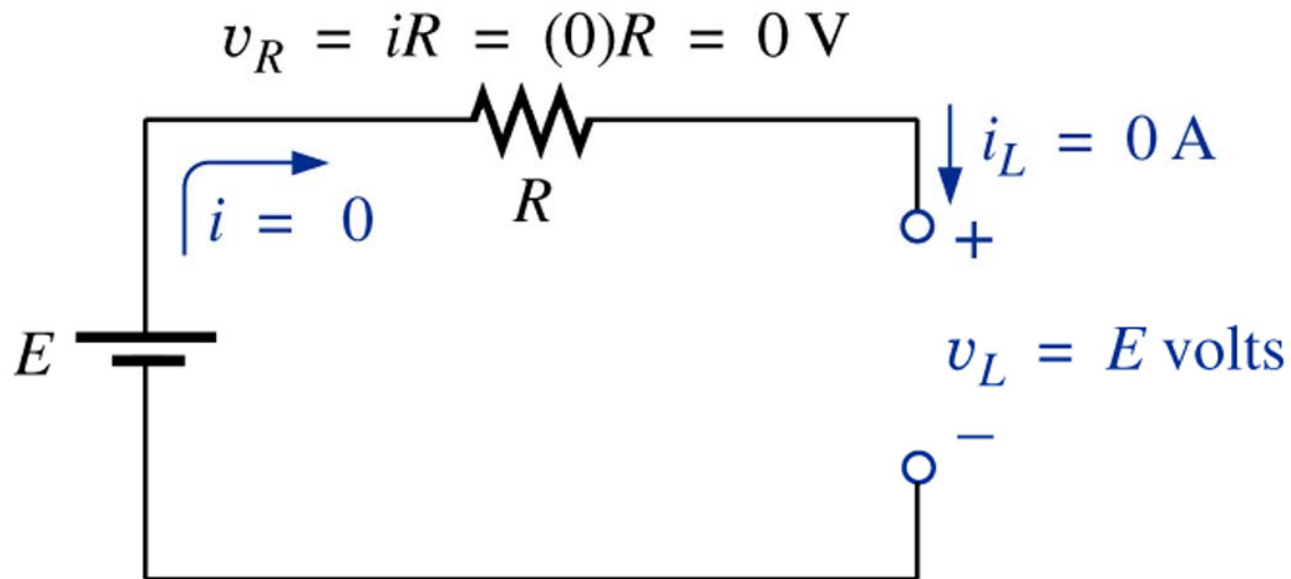

Circuito no instante que a chave é fechada:

$$v_R(0) = i \cdot R = 0 \cdot R = 0 \text{ V}$$

$$v_L(0) = E \quad i_L(0) = i_R(0) = 0 \text{ A}$$

No instante inicial, como a corrente no circuito é nula, um indutor se comporta como um circuito aberto.

# Transientes em circuitos R-L - Armazenamento

$$i_L(t) = I_m \cdot \left(1 - e^{-\frac{t}{\tau}}\right) = \frac{E}{R} \cdot \left(1 - e^{-\frac{t}{L/R}}\right)$$

$$I_m = \frac{E}{R} \quad (\text{A})$$

Corrente máxima

$$\tau = \frac{L}{R} \quad (\text{segundos, s})$$

Constante de tempo

# Transientes em circuitos R-L - Armazenamento

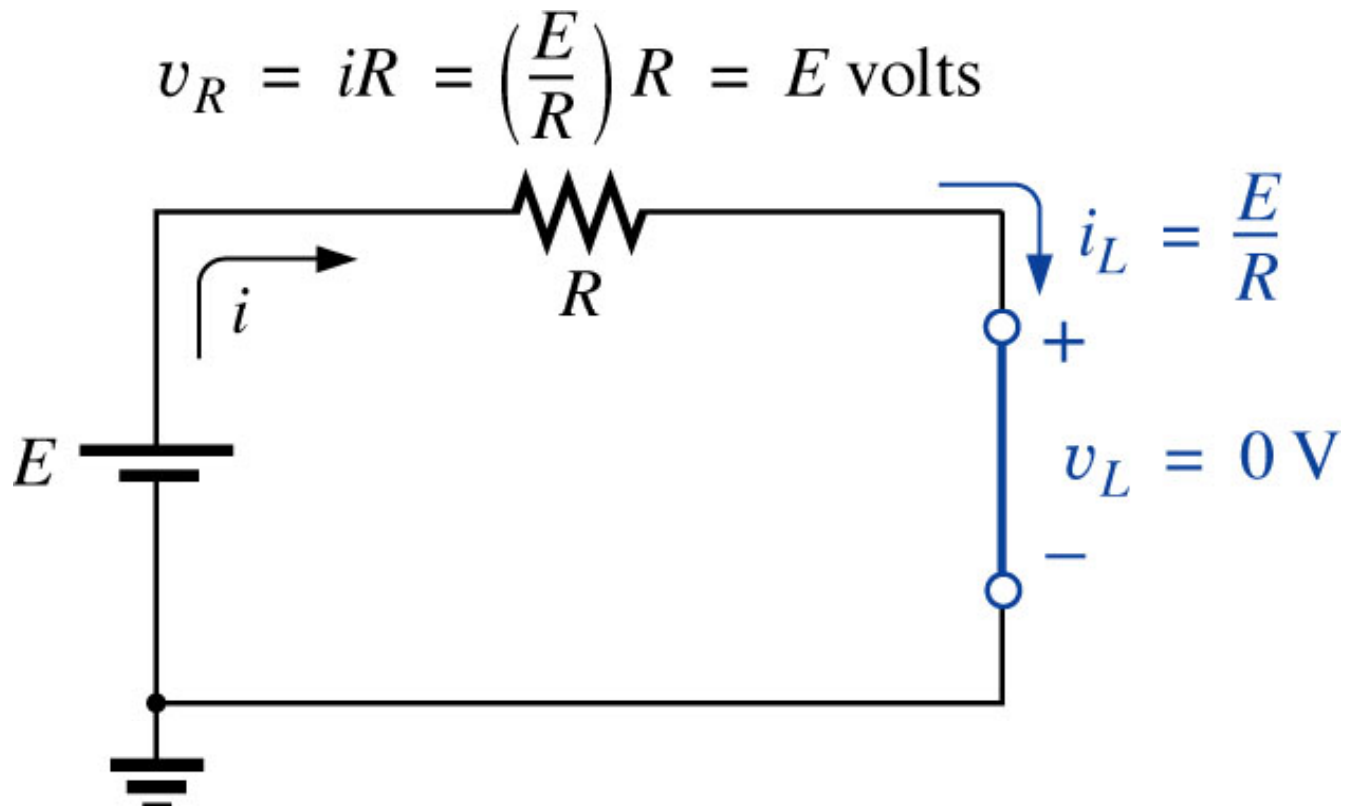

Em regime permanente, passado o transitório de armazenamento de energia, um indutor se comporta como um curto-circuito.

# Transientes em circuitos R-L - Armazenamento

$$i_L(\infty) = I_m \cdot \left(1 - e^{-\frac{\infty}{\tau}}\right) = \frac{E}{R} \cdot (1 - 0) = \frac{E}{R}$$

$$i_L(\infty) = \frac{E}{R}$$

Corrente em regime permanente

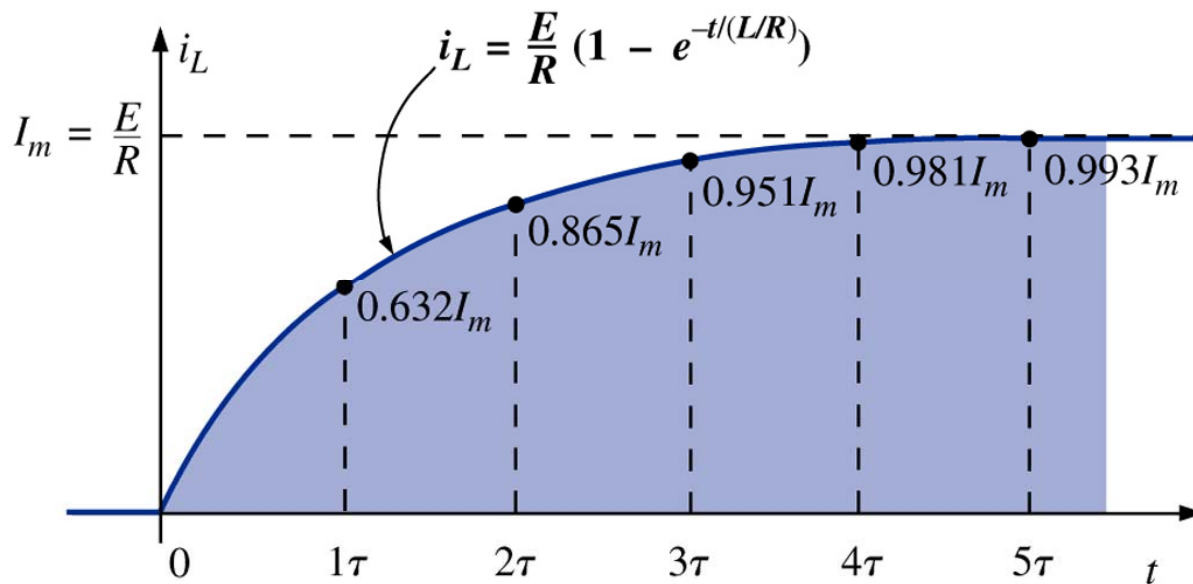

# Transientes em circuitos R-L - Armazenamento

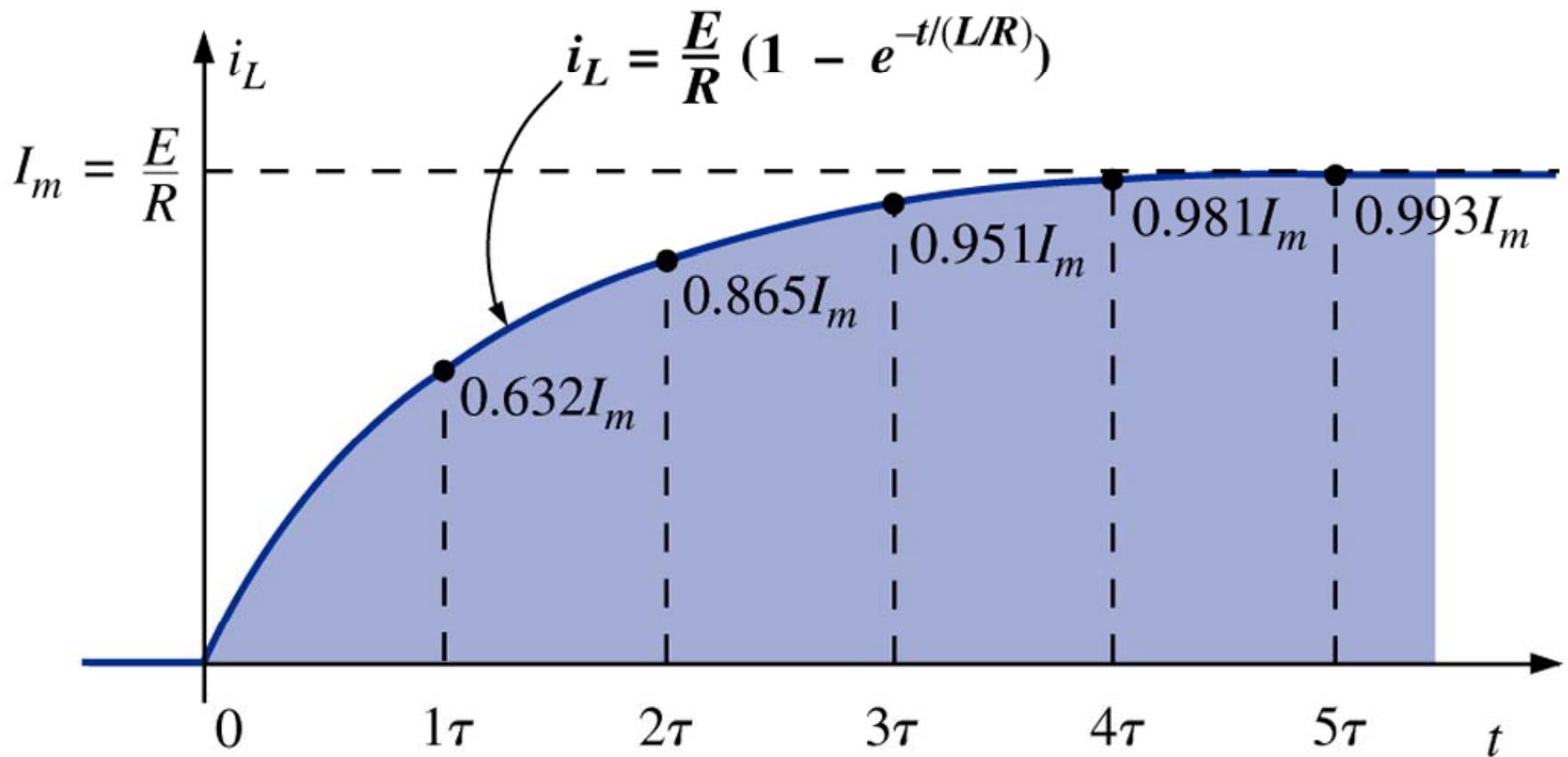

# Transientes em circuitos R-L - Descarga

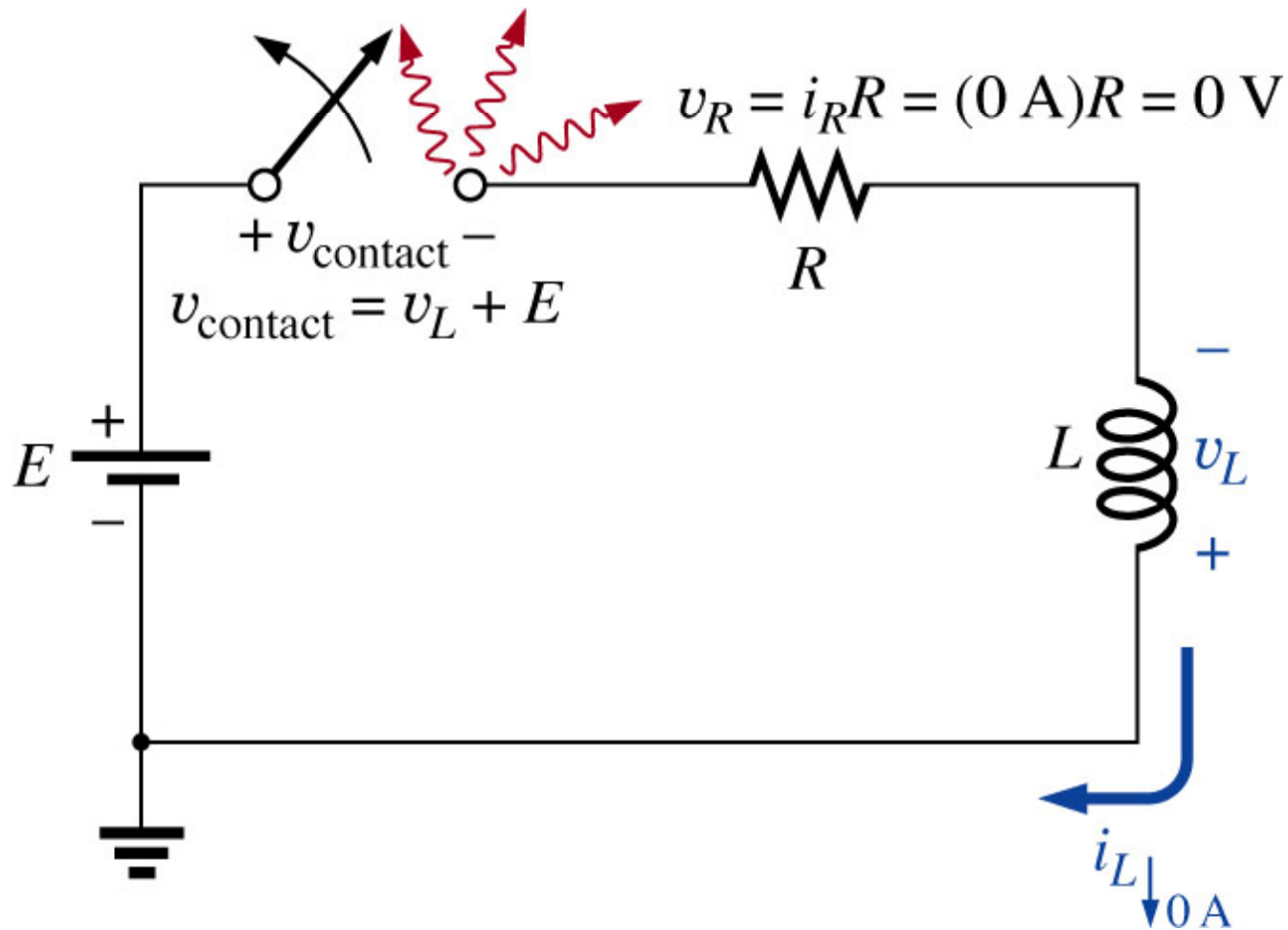

Abertura de um circuito indutivo.

# Transientes em circuitos R-L - Descarga

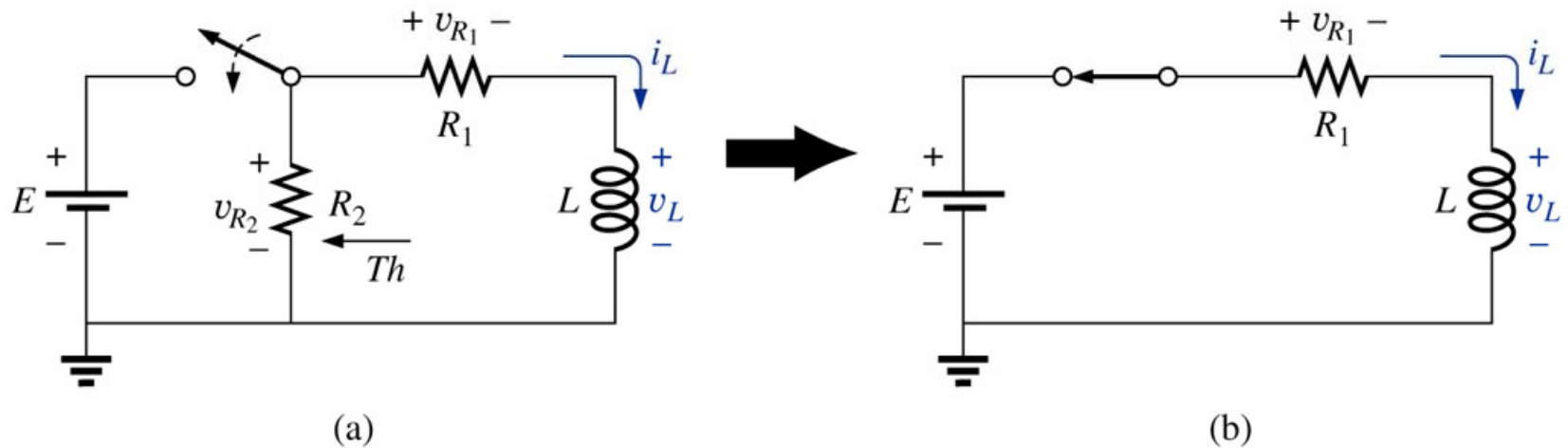

Armazenamento de energia no indutor quando a chave é fechada.

$$i_L(t^-) = \frac{E}{R}$$

$$v_L(t^-) = 0$$

$$v_R(t^-) = E$$

# Transientes em circuitos R-L - Descarga

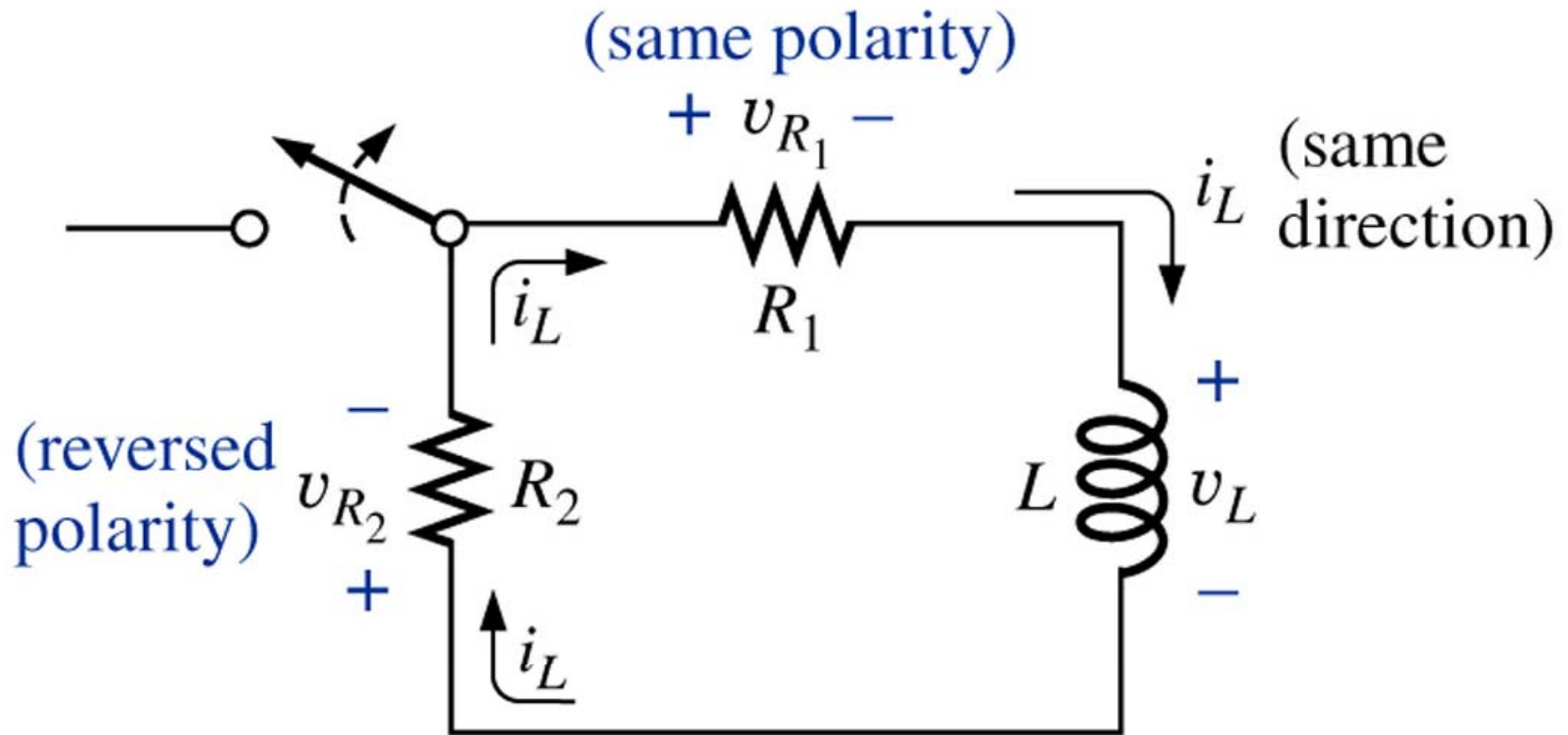

Um indutor tende a manter a corrente que por ele estava circulando, se opondo às variações de corrente e fluxo.

# Transientes em circuitos R-L - Descarga

$$v_L(t^+) = -\left(v_{R1}(t^+) + v_{R2}(t^+)\right)$$

$$v_L(t^+) = -(i_1 \cdot R_1 + i_2 \cdot R_2)$$

$$v_L(t^+) = -i_L(t^+)(R_1 + R_2)$$

$$v_L(t^+) = -\frac{E}{R_1}(R_1 + R_2)$$

$$v_L(t^+) = -E\left(1 + \frac{R_2}{R_1}\right) \longrightarrow V_i = E\left(1 + \frac{R_2}{R_1}\right)$$

$$v_L(t) = -V_i \cdot e^{-\frac{t}{\tau'}}$$

$$\tau' = \frac{L}{R_1 + R_2}$$

$$i_L(t) = \frac{E}{R_1} \cdot e^{-\frac{t}{\tau'}}$$

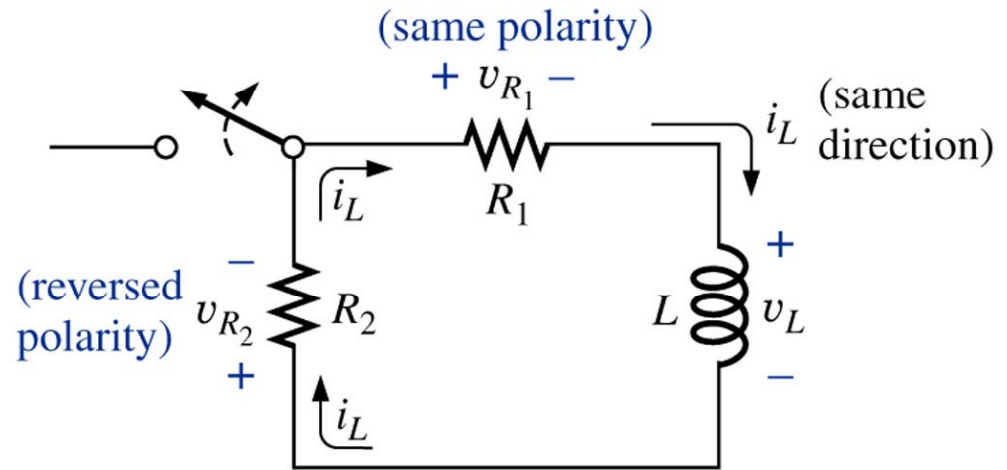

# Transientes em circuitos R-L – Carga e descarga

Exemplo 12.6: Determine as expressões matemáticas para o circuito abaixo.

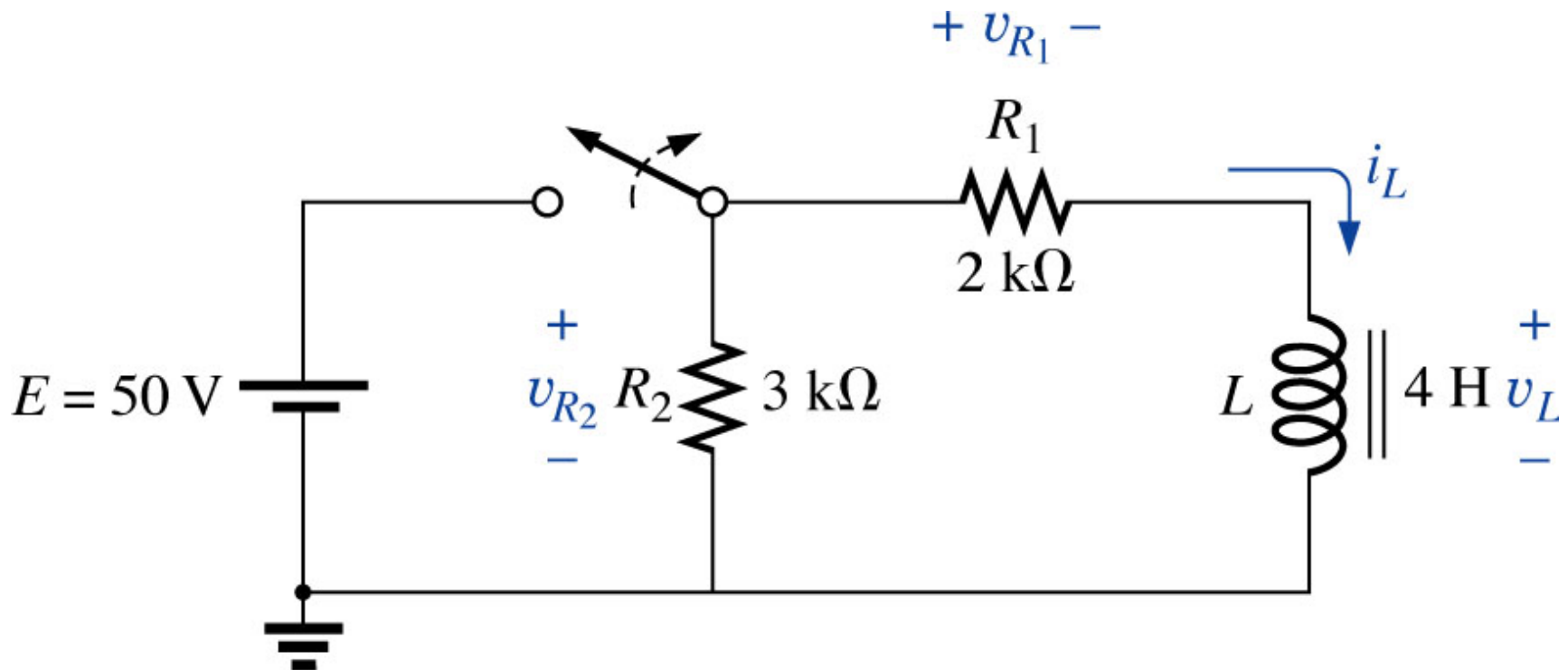

# Transientes em circuitos R-L – Carga e descarga

**Durante a carga:**

$$\tau = \frac{L}{R_1} = \frac{4}{2k} = 2 \text{ ms}$$

$$I_m = \frac{E}{R} = \frac{50}{2k} = 25 \text{ mA}$$

$$i_L(t) = 25 \cdot 10^{-3} \cdot \left( 1 - e^{-\frac{t}{2 \cdot 10^{-3}}} \right)$$

$$v_L(t) = E e^{-\frac{t}{\tau}} = 50 \cdot e^{-\frac{t}{2 \cdot 10^{-3}}}$$

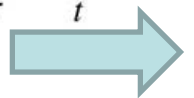
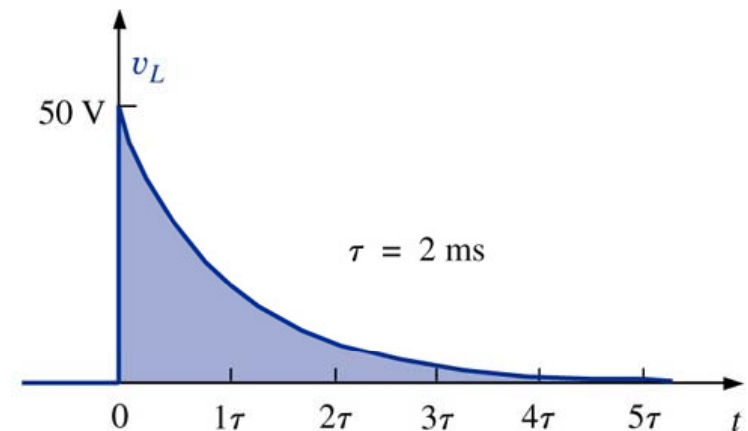
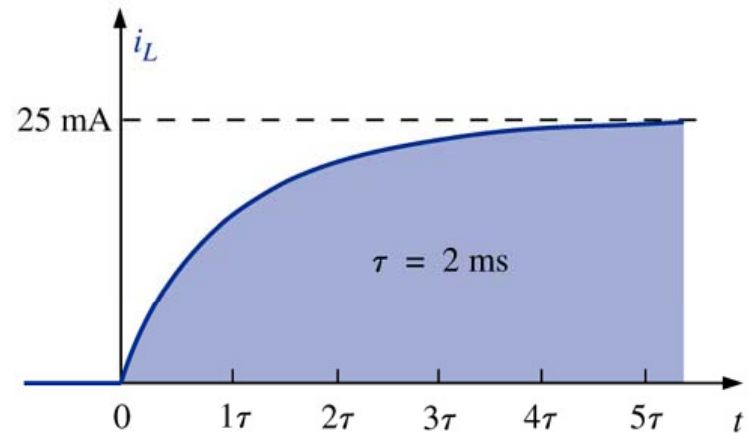

# Transientes em circuitos R-L – Carga e descarga

**Durante a descarga:**

$$\tau' = \frac{L}{R_1 + R_2} = \frac{4}{2k + 3k} = 0,8 \text{ ms}$$

$$V_i = E \left( 1 + \frac{R_2}{R_1} \right) = 50 \left( 1 + \frac{3k}{2k} \right) = 125 \text{ V}$$

$$i_L(t) = \frac{E}{R_1} \cdot e^{\frac{-t}{\tau'}} = 25 \cdot 10^{-3} \cdot e^{0,8 \cdot 10^{-3} \cdot (-t)}$$

$$v_L(t) = -V_i \cdot e^{\frac{-t}{\tau'}} = -125 \cdot e^{0,8 \cdot 10^{-3} \cdot (-t)}$$

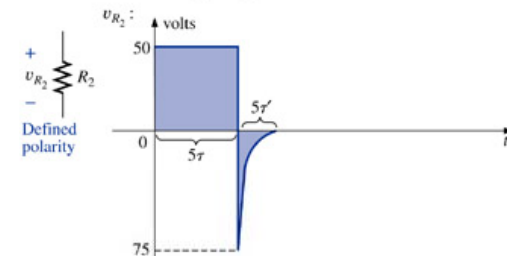
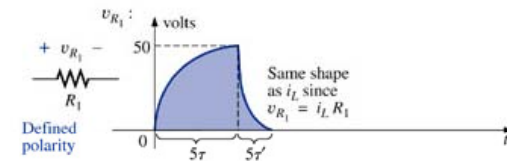
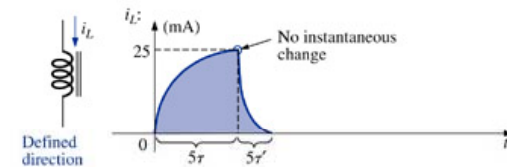
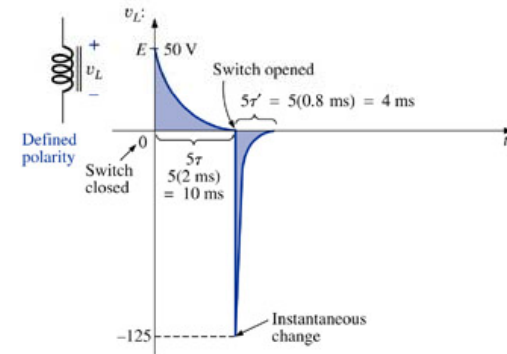

# Transientes em circuitos R-L – Carga e descarga

Exemplo 12.7: Determine as expressões matemáticas para o circuito abaixo.

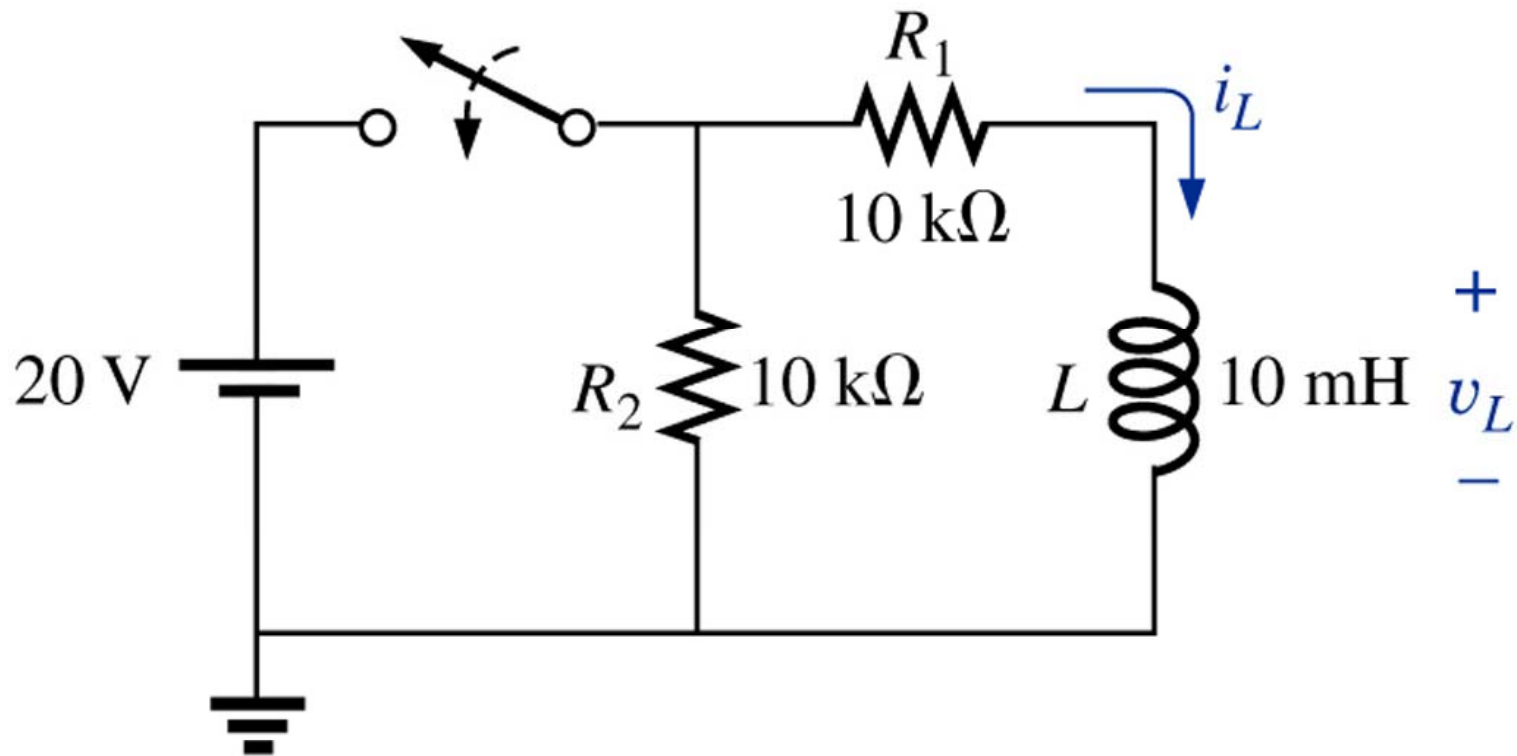

# Indutores em série e em paralelo

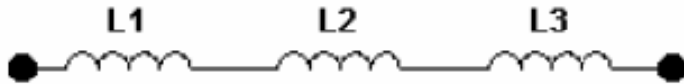

$$L_{eq} = L_1 + L_2 + L_3 + \dots L_n$$

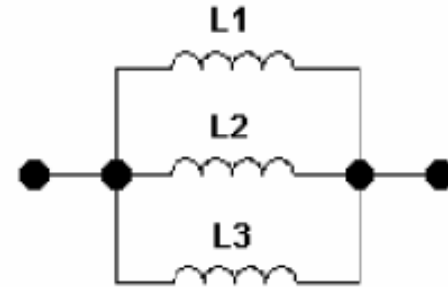

$$\frac{1}{L_{eq}} = \frac{1}{L_1} + \frac{1}{L_2} + \frac{1}{L_3} + \dots \frac{1}{L_n}$$

Exemplo 12.9: Reduza o circuito da figura abaixo à forma mais simples.

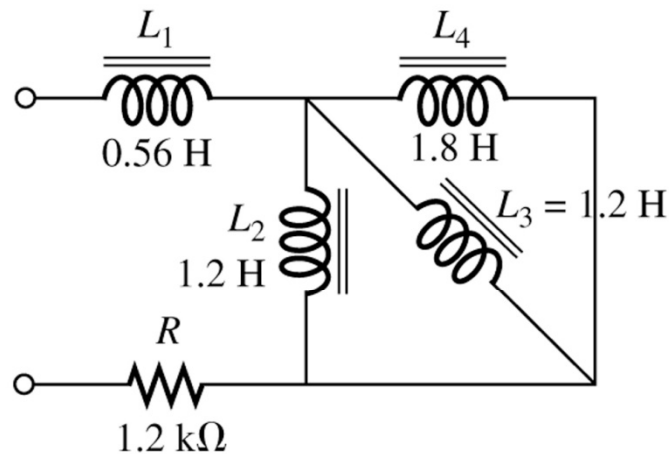

# Energia armazenada por um indutor

$$W_{armazenada} = \frac{1}{2} L \cdot I^2$$

Curva de potência de um indutor durante o transitório de carga.

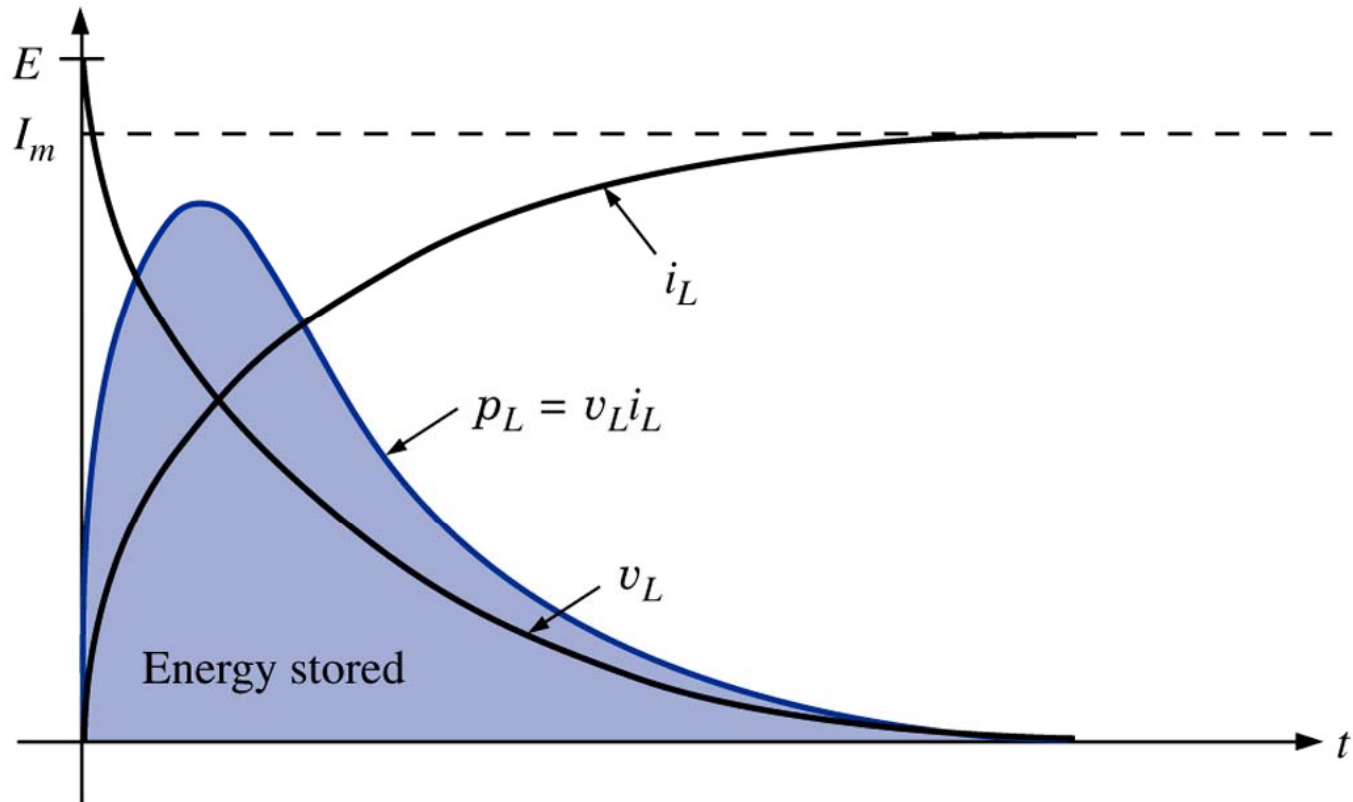

# Energia armazenada por um indutor

Exemplo 12.12: Calcule a energia armazenada pelo indutor da figura abaixo.

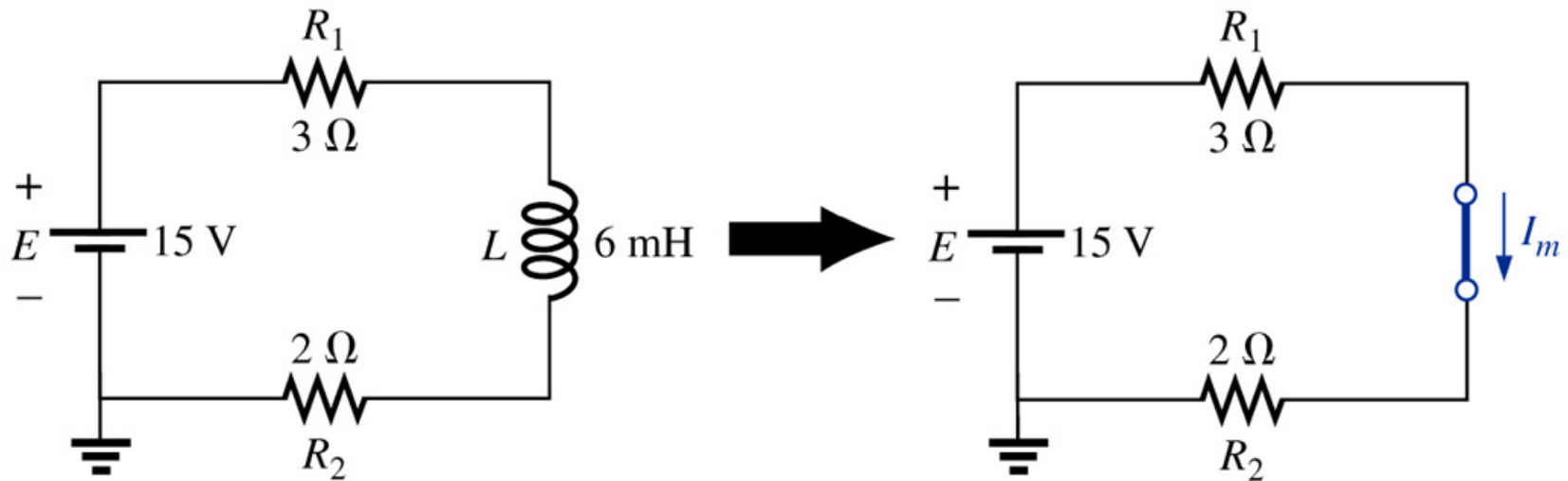

$$I_m = \frac{E}{R_1 + R_2} = \frac{15}{3 + 2} = 3\ \text{A}$$

$$W_{\text{armazenada}} = \frac{1}{2} L \cdot I^2 = \frac{1}{2} 6 \cdot 10^{-3} \cdot 3^2 = 27\ \text{mJ}$$

# Aplicações – Lâmpada de flash

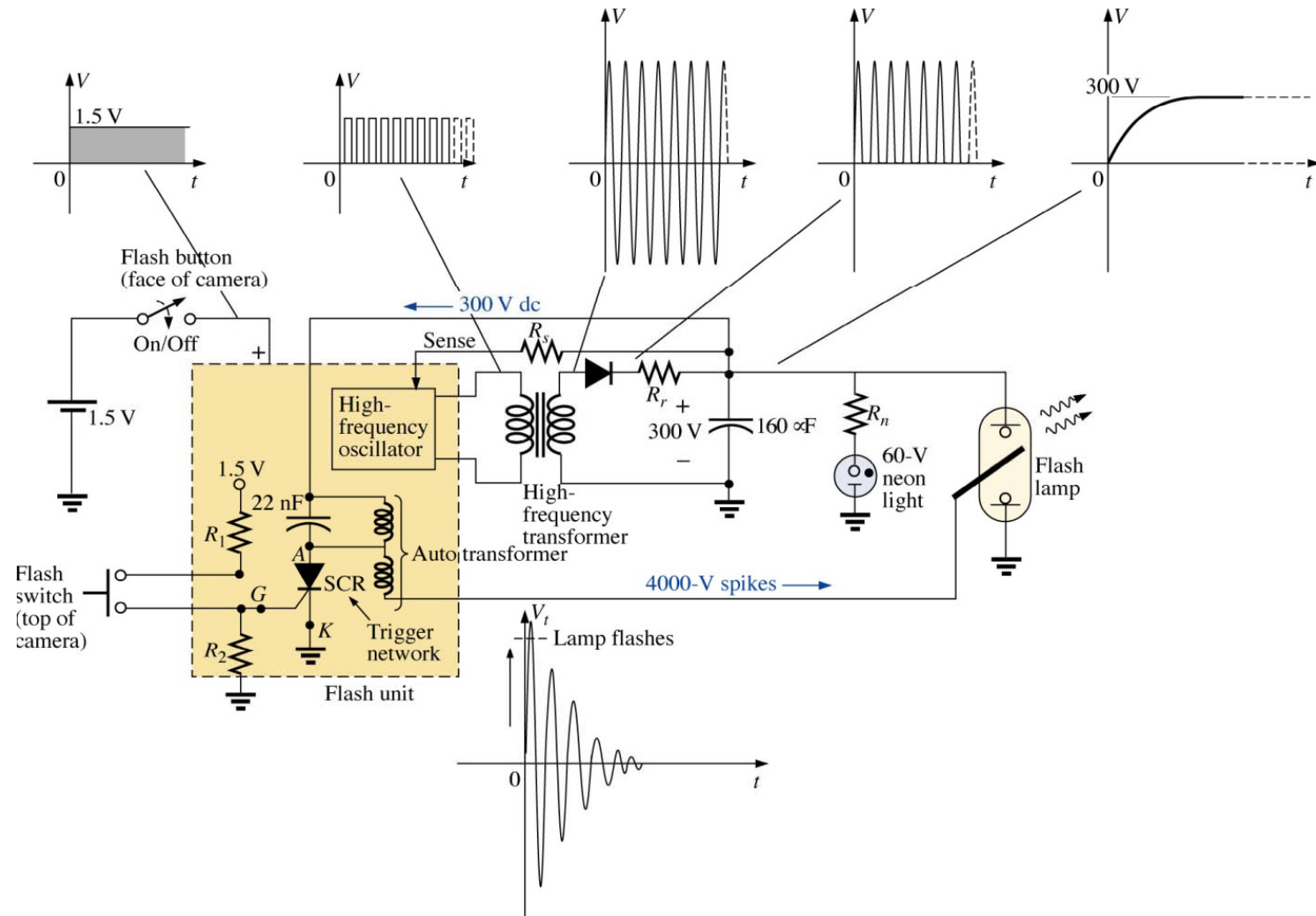

# Aplicações – Lâmpada de flash

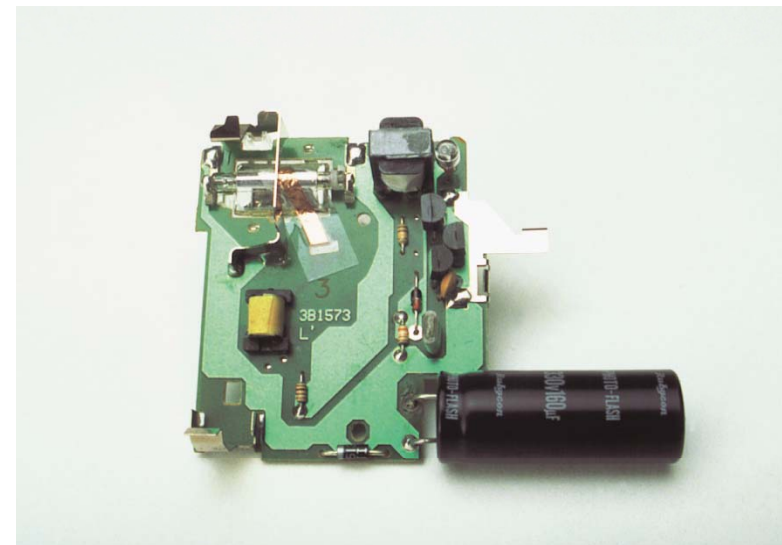
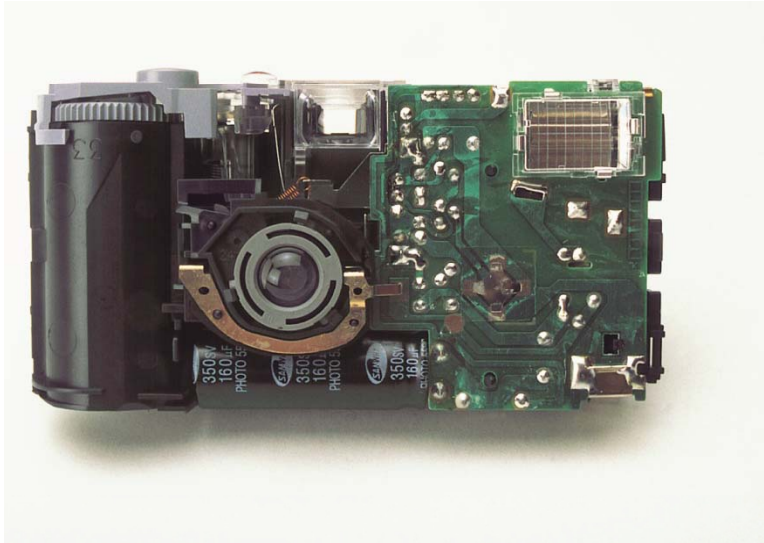

# Aplicações – Dimmer

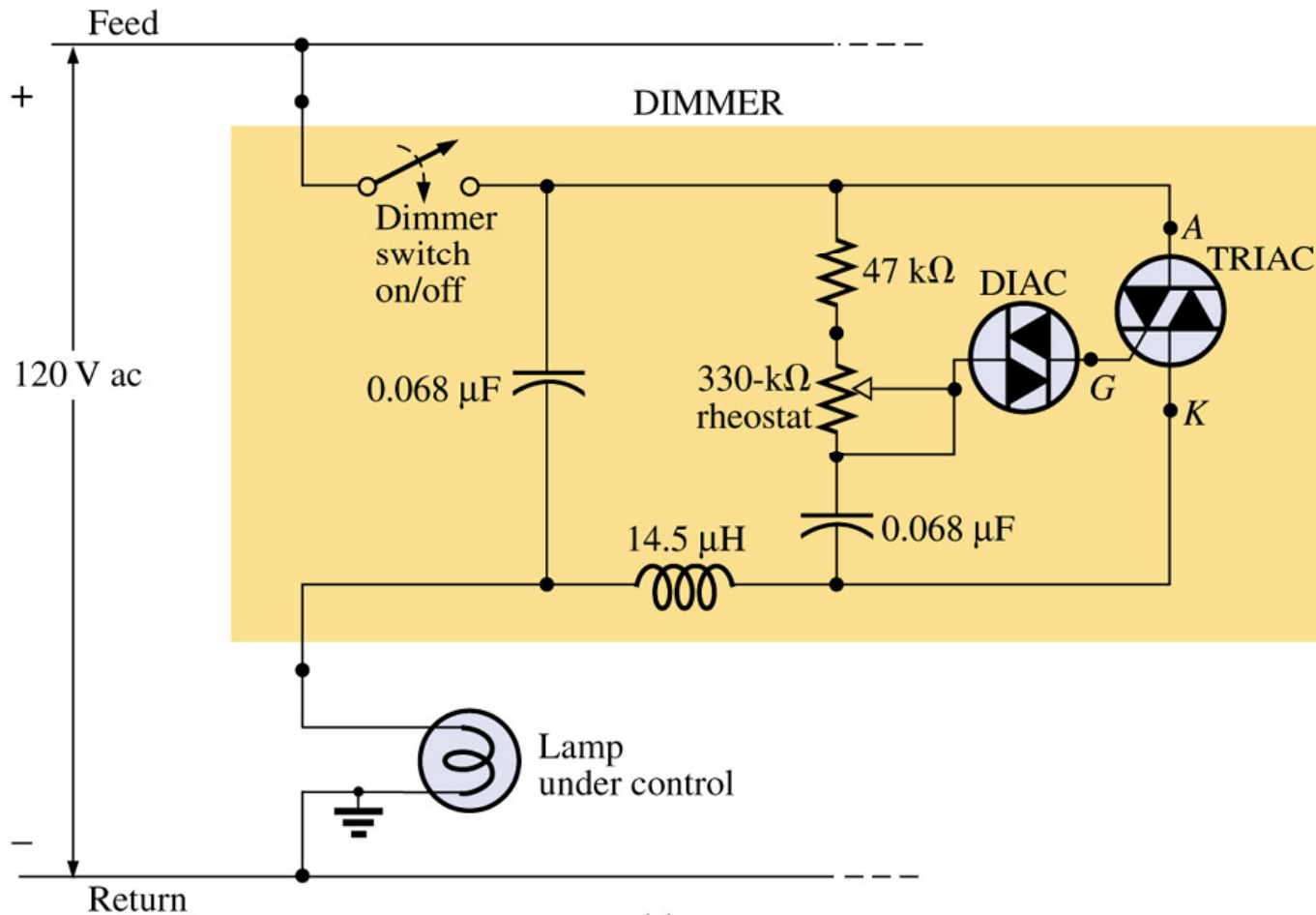

(c)

# Aplicações – Dimmer

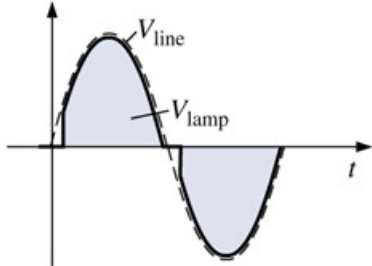
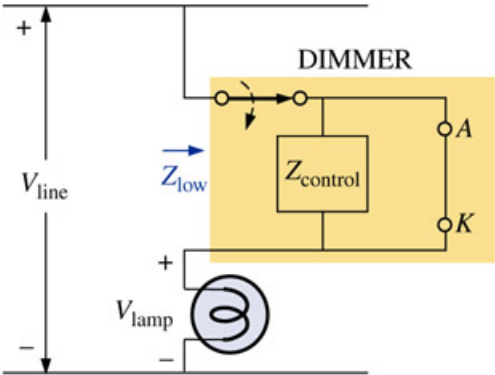

(a)

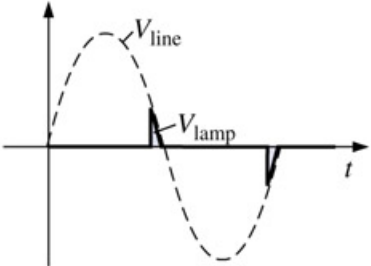
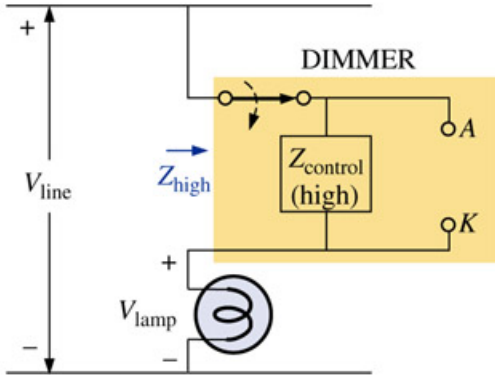

(b)

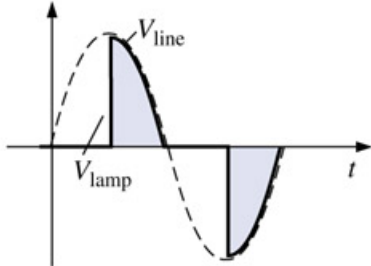
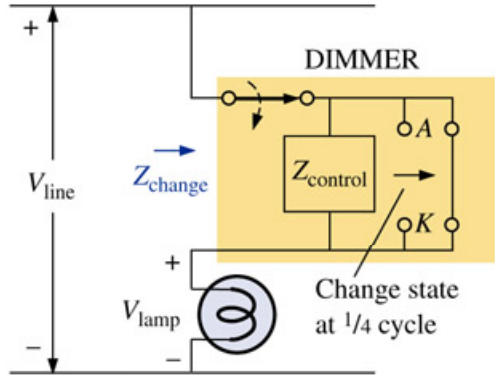

(c)

# Aplicações – Dimmer

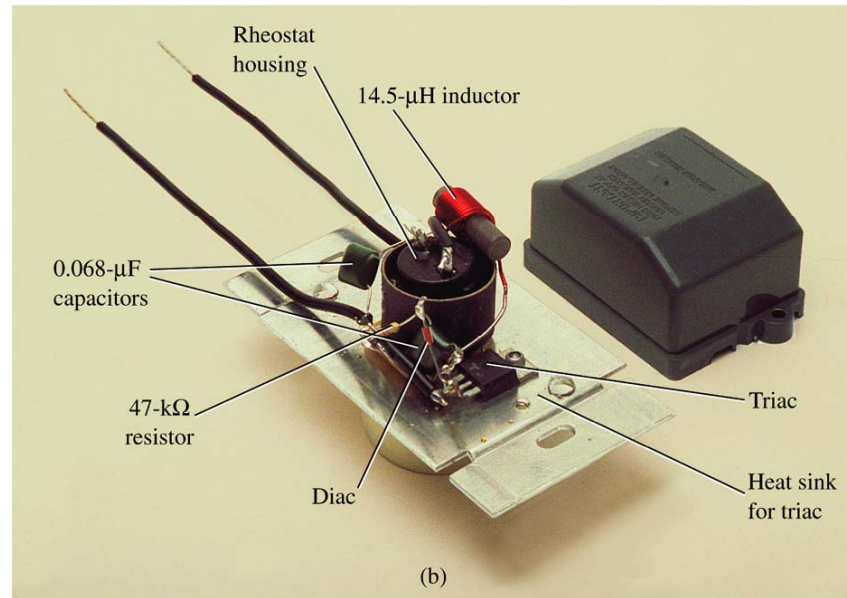
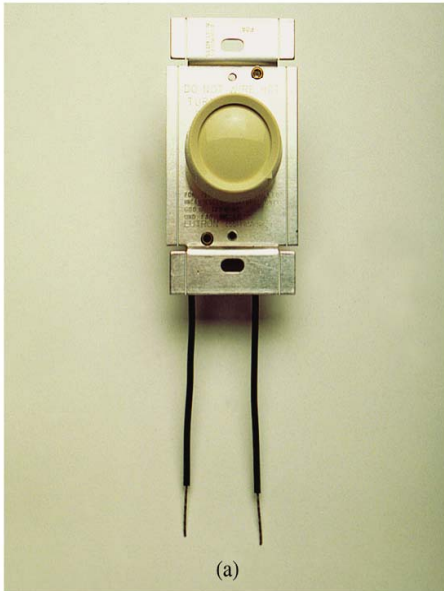

# Aplicações – Filtro de linha

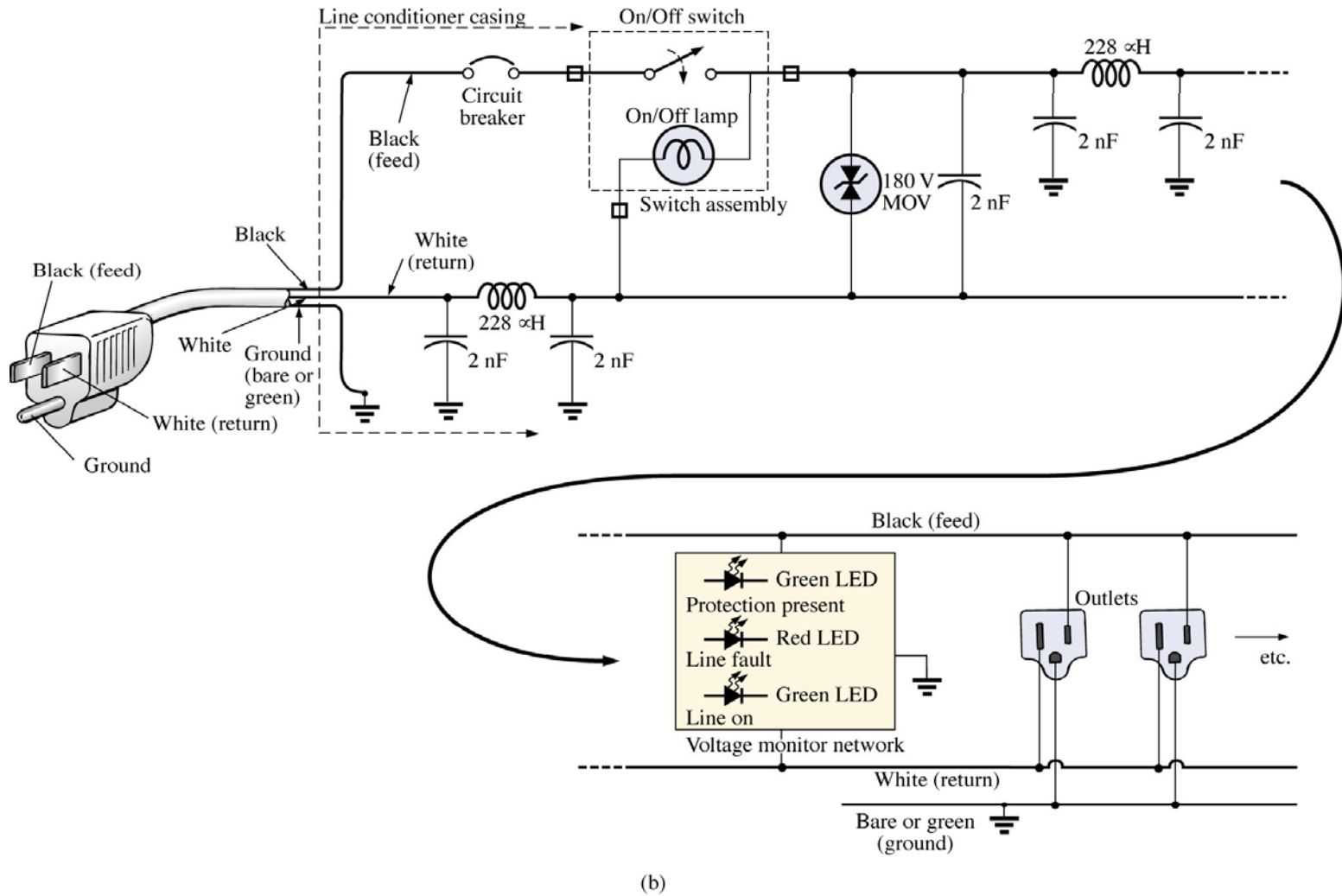

# Aplicações – Filtro de linha

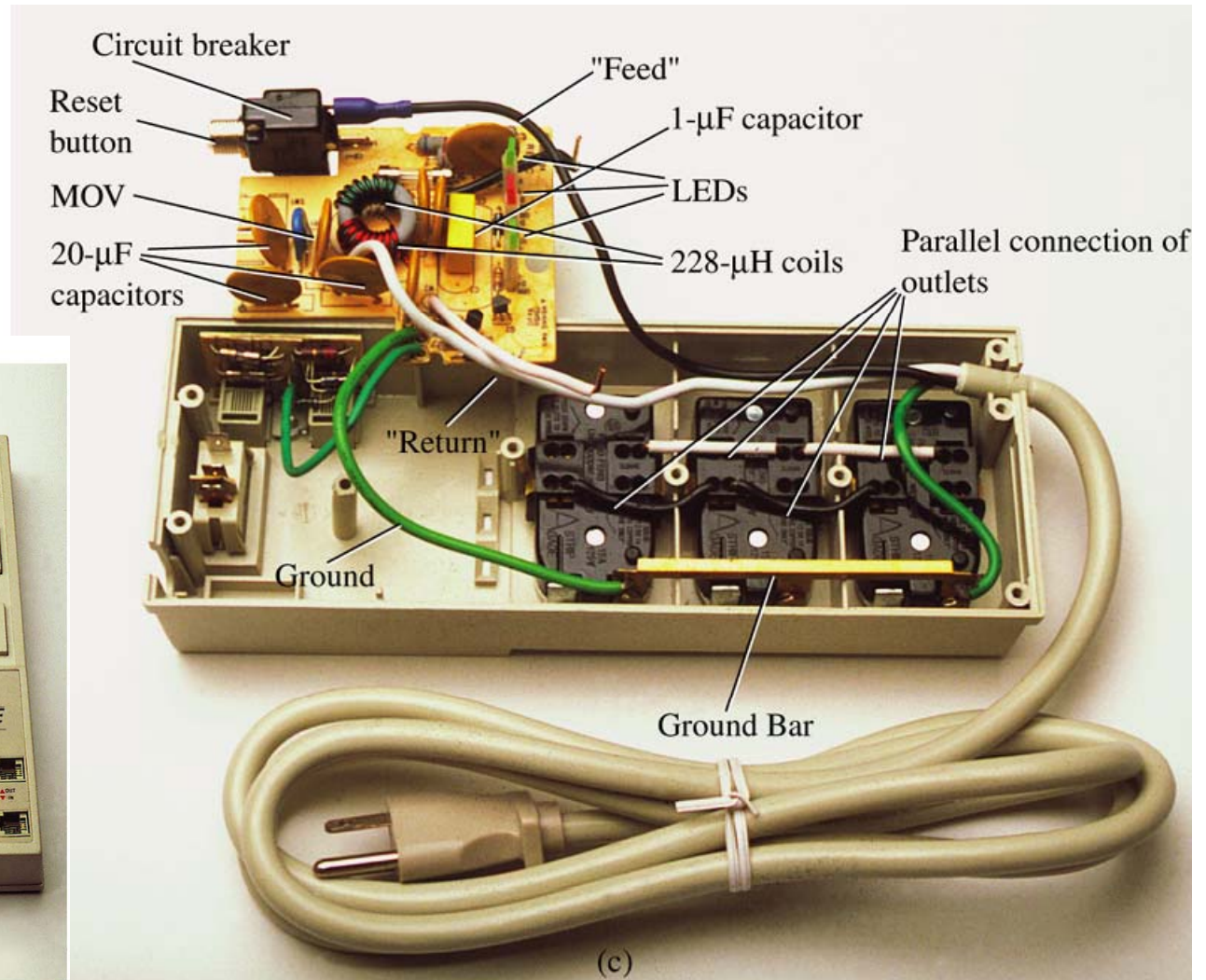

# Na próxima aula

## Capítulo 21: Transformadores

1. Projeto de indutores;
2. Indutância mútua;
3. Transformador com núcleo de ferro.

